

REV.	ECN NUMBER	DESCRIPTION	DATE	DRAWN	CHECKED	APPROVED
A	PDR18251	NEW RELEASE	8-SEP-2019	LIU SHOU PIN	ZHANG SHUNHUA	ZHANG SHUNHUA

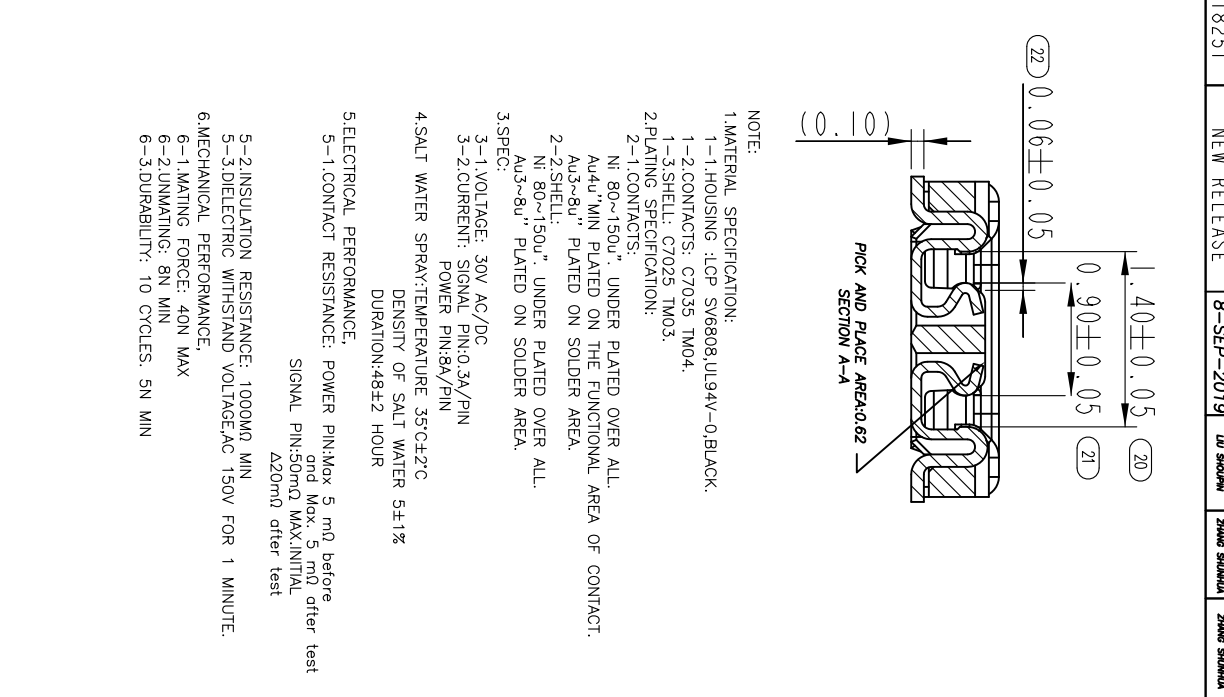
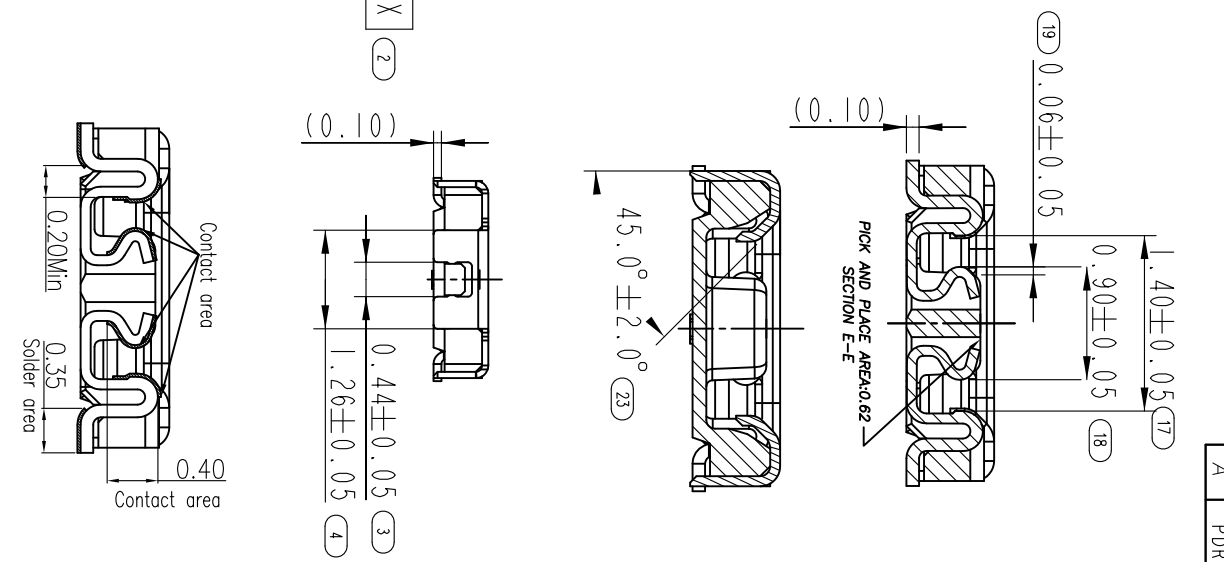
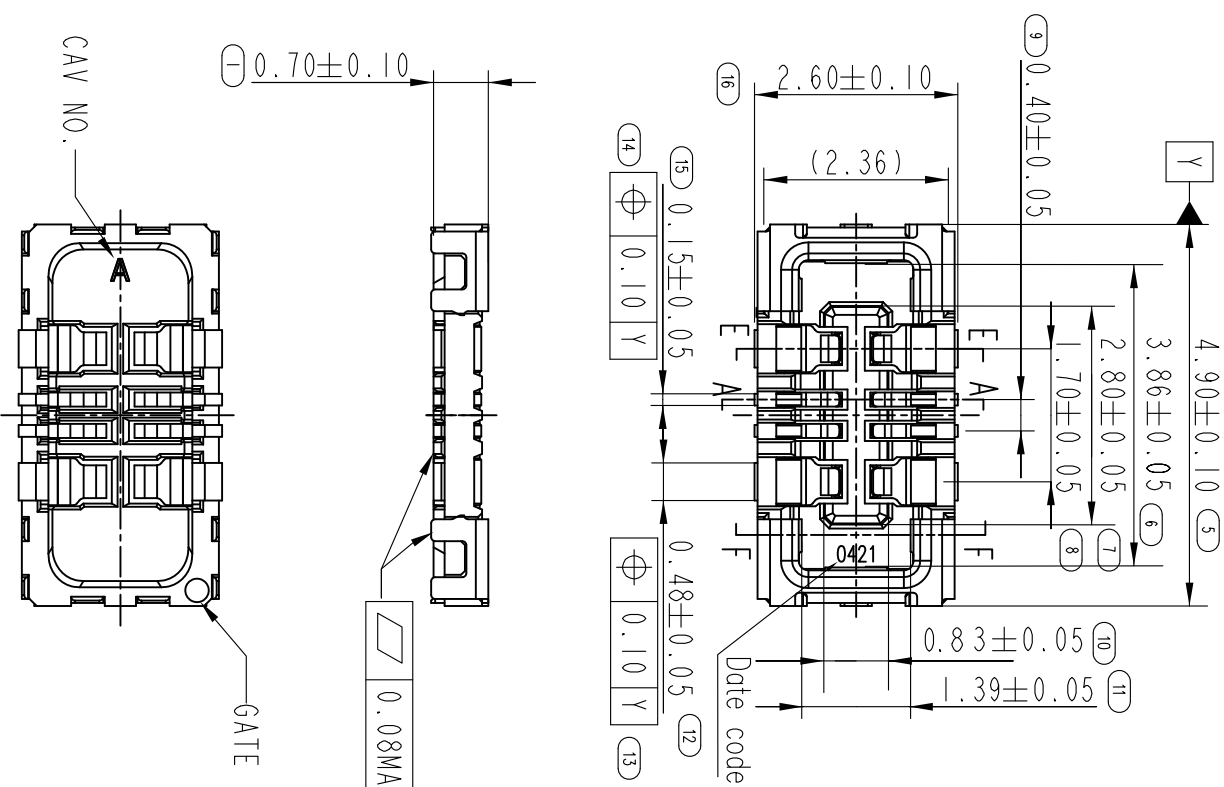

NOTE:
 1.MATERIAL SPECIFICATION:
 1-1.HOUSING: LCP SV6808,U.94V-0,BLACK.
 1-2.CONTACTS: C7035 TM04.
 1-3.SHELL: C7025 TM03.
 2.PLATING SPECIFICATION:
 2-1.CONTACTS:
 Ni 80~150u", UNDER PLATED OVER ALL.
 Au4u" MIN PLATED ON THE FUNCTIONAL AREA OF CONTACT.
 Au3~8u" PLATED ON SOLDER AREA.
 2-2.SHELL:
 Ni 80~150u", UNDER PLATED OVER ALL.
 Au3~8u" PLATED ON SOLDER AREA.
 3.SPEC:
 3-1.VOLTAGE: 30V AC/DC
 3-2.CURRENT: SIGNAL PIN:0.3A/PIN
 POWER PIN:8A/PIN
 4.SALT WATER SPRAY:TEMPERATURE 35°C±2°C
 DENSITY OF SALT WATER 5±1%
 DURATION:48±2 HOUR
 5.ELECTRICAL PERFORMANCE:
 5-1.CONTACT RESISTANCE: POWER PIN:Max 5 mΩ before
 and Max 5 mΩ after test
 SIGNAL PIN:50mΩ MAX,INITIAL
 Δ20mΩ after test
 5-2.INSULATION RESISTANCE: 1000MΩ MIN
 5-3.DIELECTRIC WITHSTAND VOLTAGE:AC 150V FOR 1 MINUTE.
 6.MECHANICAL PERFORMANCE:
 6-1.MATING FORCE: 40N MAX
 6-2.UNMATING: 8N MIN
 6-3.DURABILITY: 10 CYCLES, 5N MIN

		GENERAL TOLERANCE >30~60 ±0.15 >15~30 ±0.10 >6~15 ±0.08 >0-6 ±0.05		SCALE: 10.000		DRAWN LIU SHOU PIN		DATE 8-SEP-2019		DWG. NO. 600-21442-03		TITLE CUSTOMER DRAWING BTB CONN HO.7 8P RECEP Avoid HSG		REV. A	
UNIT: MM		SCALE: 10.000		CHECK ZHANG SHUNHUA		DATE 8-SEP-2019		CHECK ZHANG SHUNHUA		DATE 8-SEP-2019		PARTS NO. (INTENDED USE) 818021442		SHEET 1/3	
SIZE: A4		SCALE: 10.000		APPROVE ZHANG SHUNHUA		DATE 8-SEP-2019		DATE 8-SEP-2019		DATE 8-SEP-2019		DATE 8-SEP-2019		DATE 8-SEP-2019	

REV.	ECN NUMBER	DESCRIPTION	DATE	DRAWN	CHECKED	APPROVED
A	PDR18251	NEW RELEASE	8-SEP-2019	LIU SHOUPIU	ZHANG SHUNHUA	ZHANG SHUNHUA

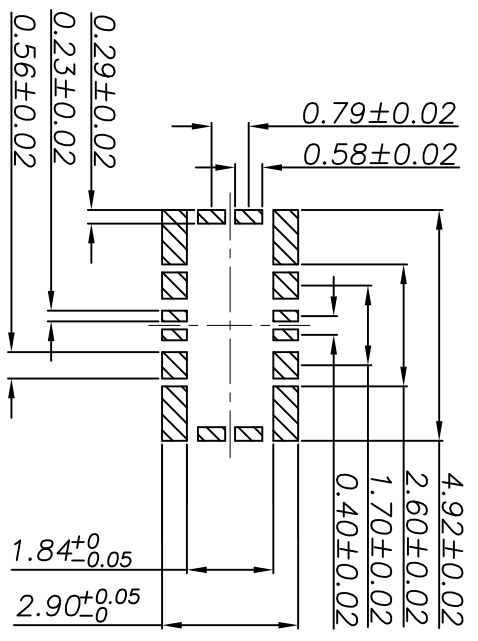

RECOMMEND ELECTRICAL CIRCUIT LAYOUT

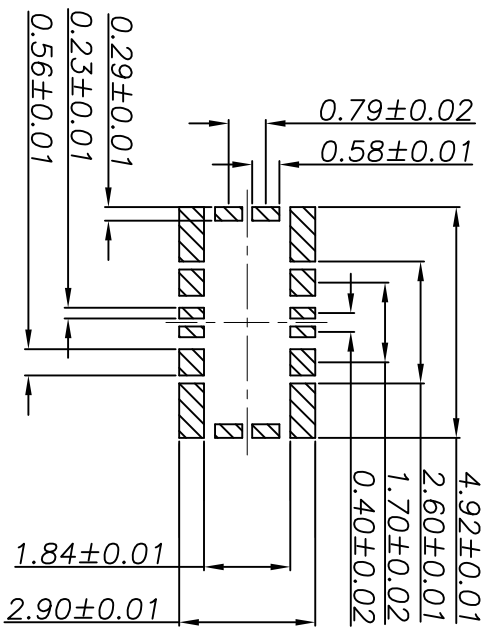
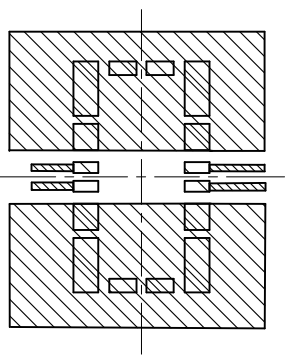

RECOMMEND METAL MASK DIMENSIONS
METAL MASK THICKNESS:80um

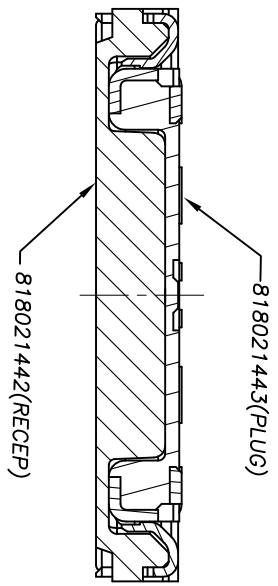
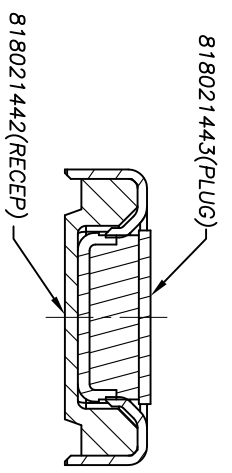
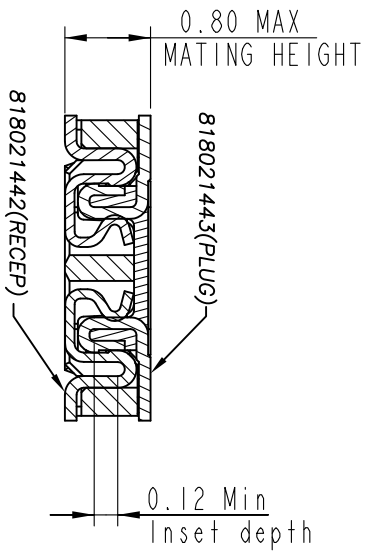

GENERAL TOLERANCE		SCALE:		DRAWN		DATE		DWG. NO.		TITLE		REV.	
>30~60 ±0.15		10.000		LIU SHOUPIU	8-SEP-2019	600-21442-03		CUSTOMER DRAWING	A				
>15~30 ±0.10	X° ±2.0°	UNIT:	MM	CHECK	DATE	PARTS NO. (INTENDED USE)		BTB CONN HO.7 8P RECEP					
>6~15 ±0.08	X' ±1.0°	SIZE:	A4	APPROVE	DATE			Avoid HSG					
>0-6 ±0.05	.XX' ±0.5°			ZHANG SHUNHUA	8-SEP-2019	818021442							2/3

Rev.	ECN Number	Description	Date	Drawn	Checked	Approved
A	PIR0251	FIRST RELEASE	8-SEP-2019	LIU SHUOPIN	ZHANG SHUNHUA	ZHANG SHUNHUA

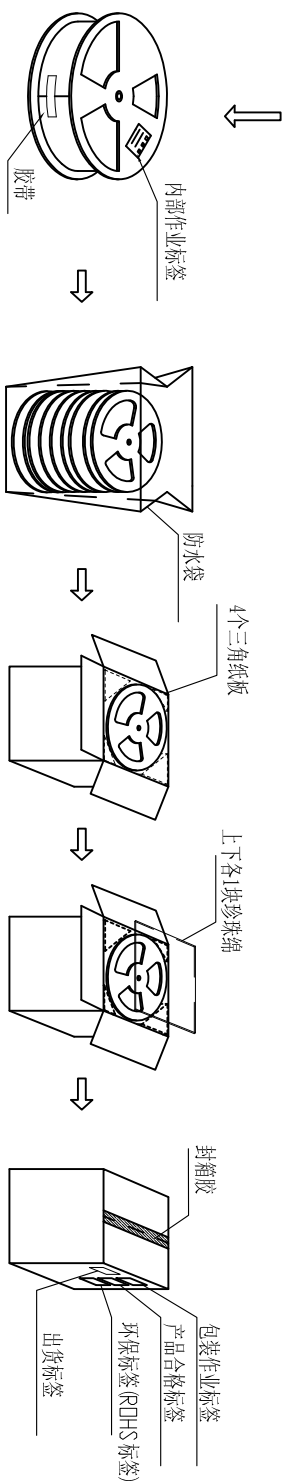
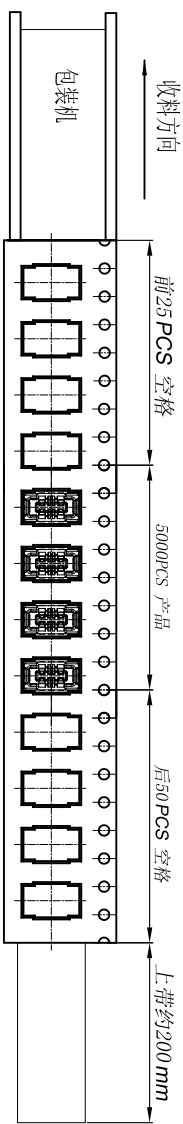
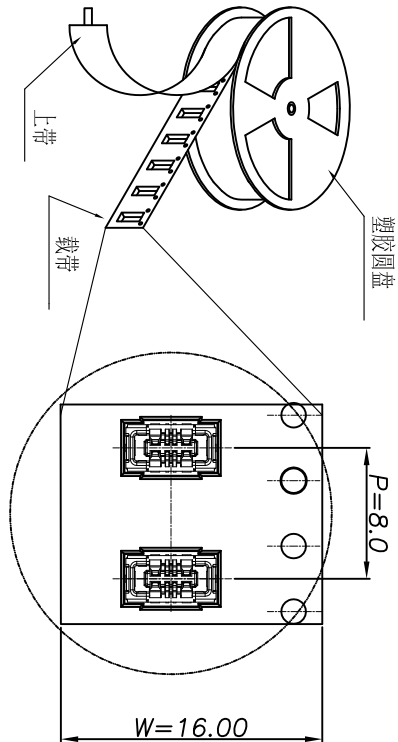

- 管制重点:
1. 包装时产品轻拿轻放, 避免产品变形.
 2. 整盘包装好后, 检查是否有漏装, 产品的放置方向是否正确.
 3. 包装裁带断裂时不可用人工连接.
 4. 检查是否有产品被压死, 检查整盘层数是否正确.
 5. 若有未装满之零数箱, 须以缓冲材塞满.
 6. 防水袋封口须密封.
 7. 整箱封好后, 检查标签是否贴好, 干净, 字迹清晰, 标签内容是否正确, 完善.
 8. 外纸箱: (840000602) 内尺寸: 340*W340*H315mm

PN NO.	产品料号	载带料号	塑胶圆盘	上带	PCS/盘	盘/外箱	PCS/外箱
08	818021442	7313040001	840000402	840000302	5000	14	70000

ELECTRIC CONNECTOR TECHNOLOGY

GENERAL TOLERANCE

XX ±0.40	X ±2.0°
X ±0.25	X ±1.0°
X ±0.13	XX ±0.5°
XX ±0.05	

SCALE: 1:1

UNIT: mm

SIZE: A4

DRAWN: LIU SHUOPIN

CHECK: ZHANG SHUNHUA

APPROVE: ZHANG SHUNHUA

DATE: 8-SEP-2019

DATE: 8-SEP-2019

DATE: 8-SEP-2019

DWG. NO. 551-21442-03

PARTS NO.(INTENDED USE) 818021442

TITLE

BTB RECEP CONN NO. 7 8P 包装规范

REV. A

SHEET 3/3

REV. A

SHEET 3/3