

### Descriptions

The TS5USBC412YFFR-TP is a bidirectional low-power dual port, high-speed, USB 2.0 analog switch with integrated protection for USB Type-C™ systems. The device is configured as a dual 2:1 or 1:2 switch. It is optimized for use with the USB 2.0 DP/DM lines in a USB Type-C™ system .

The TS5USBC412YFFR-TP integrated over-voltage protection on the D+/- pins can withstand up to DC 30V with automatic shutoff circuitry in order to protect system components behind the switch. GPIO controls of S1, S2 and \_OE are 1.8V logic compatible. The TS5USBC412YFFR-TP is available in 12 Ball Wafer Level Chip Scale Package (WLCSP) with 1.2x1.6x0.6mm with Pb-free and Halogen-free making it a perfect candidate for mobile and space constrained applications.

### Features

- Supply Range 2.5 V to 5.5 V
- Differential 2:1 or 1:2 Switch/Multiplexer
- Up to DC 30V Overvoltage Protection (OVP) on D+/- Ports
- IEC 64000-4-5 Surge Protection w/o External TVS onto D+/- Ports:  $\pm 30V$
- System Side Clamp Voltage Pulse Less than 9V, Duration Less than 200ns
- Powered Off Protection When VCC = 0 V
- Low RON of 10  $\Omega$  Typical
- Insertion loss: -1dB@200MHz, -2dB@650MHz, **-3dB@1GHz**
- C<sub>ON</sub> of 4.8 pF
- 1.8-V Compatible Logic Inputs
- Standard Temperature Range of 0°C to 85°C

### Applications

- Anywhere a USB Type-C™ or Micro-B Connector is Used
- Mobile Phones, Tablets and Notebooks

**Functions and Pin Configuration**

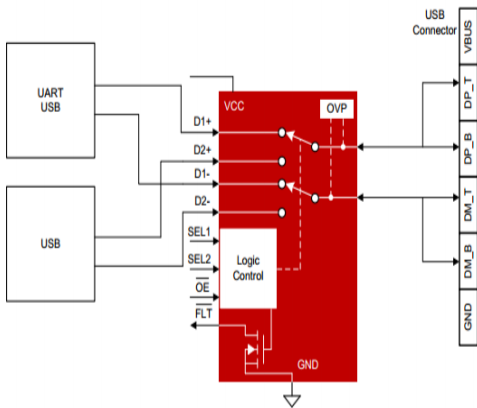

**Fig.1 Functional Diagram**

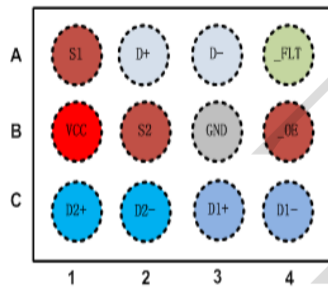

**Fig.2 Top-Through View**

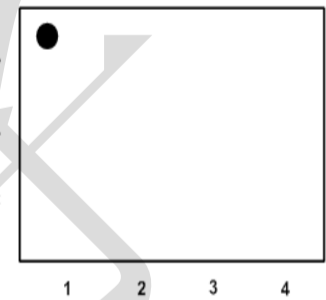

**Fig.3 Top Side Marking View**

**Pin Descriptions**

| Pin | Name | Type | Description                                    |
|-----|------|------|--|
| A1  | S1   | I    | Switch Select 1 (Active High)                  |
| A2  | D+   | I/O  | Data switch input (Differential +)             |
| A3  | D-   | I/O  | Data switch input (Differential -)             |
| A4  | _FLT | O    | Fault indicator output (Active Low) open drain |
| B1  | VCC  | PWR  | Power Supply                                   |
| B2  | S2   | I    | Switch Select 2 (Active High)                  |
| B3  | GND  | GND  | Ground   |
| B4  | _OE  | I    | Output Enable (Active Low)                     |
| C1  | D2+  | I/O  | Data switch output 2 (Differential +)          |
| C2  | D2-  | I/O  | Data switch output 2 (Differential -)          |
| C3  | D1+  | I/O  | Data switch output 1 (Differential +)          |
| C4  | D1-  | I/O  | Data switch output 1 (Differential -)          |

**Table-1 Pin Descriptions**

**Electrical Characteristics (Ta=25°C, VCC=3.3V, unless otherwise specified)**

| Parameter  | Symbol             | Conditions  | Min. | Typ. | Max. | Unit |
|--|--------------------|---|------|------|------|------|
| <b>POWER SUPPLY</b>                                      |                    |   |      |      |      |      |
| Supply Voltage Range                                     | V <sub>CC</sub>    |   | 2.5  | 3.3  | 5.5  | V    |
| Supply Current   | I <sub>CC</sub>    | $\_OE = 1$ disconnection  |      | 0.6  | 2    | μA   |
|  |                    | $\_OE = 0$ connection   |      | 33   |      | μA   |
| <b>S1/S2/\_OE DIGITAL INPUT CONTROL</b>                  |                    |   |      |      |      |      |
| control input logic high                                 | V <sub>IH</sub>    |   | 1.6  |      | 5.5  | V    |
| control input logic low                                  | V <sub>IL</sub>    |   | -0.1 |      | 0.5  | V    |
| Internal pull-down resistor                              | R <sub>PD</sub>    |   |      | 2    |      | MΩ   |
| <b>SWITCH ON RESISTANCE AND OFF LEAKAGE</b>              |                    |   |      |      |      |      |
| On-Resistance  | R <sub>ON</sub>    | V <sub>IS</sub> = 0V~0.4V I <sub>OUT</sub> = 8mA  |      | 10   | 11   | Ω    |
| R <sub>ON</sub> Flatness <sup>(1)</sup>                  | R <sub>FLAT</sub>  | V <sub>IS</sub> = 0V~0.4V I <sub>OUT</sub> = 8mA  |      | 0.3  | 0.5  | Ω    |
| R <sub>ON</sub> Matching Between Channels <sup>(2)</sup> | ΔR <sub>ON</sub>   | V <sub>IS</sub> = 0V~0.4V I <sub>OUT</sub> = 8mA  |      | 0.1  | 0.2  | Ω    |
| OFF Leakage Current                                      | I <sub>LEAK</sub>  | V <sub>D+/-</sub> = 10V V <sub>D1+/-</sub> = V <sub>D2+/-</sub> = 0V                                  |      | 31   | 50   | μA   |
| <b>SWITCH DYNAMICS</b>                                   |                    |   |      |      |      |      |
| On Capacitance   | C <sub>ON</sub>    | V <sub>D+/-</sub> = 0.2V, f = 1MHz  |      | 4    |      | pF   |
| Off Capacitance  | C <sub>OFF</sub>   | V <sub>D+/-</sub> = 0.2V, f = 1MHz  |      | 3    |      | pF   |
| Off Isolation  | Off                | f = 250MHz, R <sub>T</sub> = 50Ω, C <sub>L</sub> = 0pF  |      | -38  |      | dB   |
| Crosstalk <sup>(3)</sup><br>(Channel-to-Channel)         | X <sub>TALK</sub>  | f = 250MHz, R <sub>T</sub> = 50Ω, C <sub>L</sub> = 0pF  |      | -41  |      | dB   |
| -3dB Bandwidth   | BW                 | R <sub>T</sub> = 50Ω, C <sub>L</sub> = 0pF Signal Power 0dBm  | 0.9  | 1    |      | GHz  |
| Break-Before-Make  | BBM                | V <sub>D1+/-</sub> = V <sub>D2+/-</sub> = 0.4V, R <sub>L</sub> = 50Ω                                  |      | 1.5  |      | μs   |
| Turn-on Time   | t <sub>OFF</sub>   | V <sub>D+/-</sub> = 0.4V, R <sub>L</sub> = 50Ω<br>\_OE switches from High to Low                      |      | 20   |      | μs   |
| Turn-off Time  | t <sub>OFF</sub>   | V <sub>D+/-</sub> = 0.4V, R <sub>L</sub> = 50Ω<br>\_OE switches from Low to High                      |      | 1.2  |      | μs   |
| Propagation Delay  | t <sub>PD</sub>    | V <sub>D+/-</sub> = 0.4V, R <sub>L</sub> = 50Ω  |      | 200  |      | pS   |
| <b>OVER VOLTAGE PROTECTION</b>                           |                    |   |      |      |      |      |
| OVP Lockout Threshold                                    | V <sub>OVP</sub>   | V <sub>D+/-</sub> Rising Edge   | 4.6  | 4.9  | 5.2  | V    |
| OVP Hysteresis   | V <sub>HYS</sub>   | V <sub>D+/-</sub> Falling Edge  |      | 200  |      | mV   |
| Clamp Voltage on D <sub>1+/-</sub> and D <sub>2+/-</sub> | V <sub>CLAMP</sub> | 10V shorts to D <sub>+/-</sub><br>with R <sub>L</sub> = 1KΩ @ D <sub>1+/-</sub> and D <sub>2+/-</sub> |      | 6.5  | 8    | V    |
| OVP Response Time  | t <sub>FP</sub>    | 10V shorts to D <sub>+/-</sub><br>with R <sub>L</sub> = 1KΩ @ D <sub>1+/-</sub> and D <sub>2+/-</sub> |      | 200  | 300  | nS   |
| OVP Recovery Time  | t <sub>FPR</sub>   | V <sub>D+/-</sub> jumps from 6V to 1V step  | 30   | 45   | 60   | μs   |

**Note:**

**Table-2 Electrical Characteristics**

(1) Flatness is defined as the difference between maximum and minimum value of ON-resistance at the specified analog signal voltage points.

(2) R<sub>ON</sub> matching between channels is calculated by subtracting the channel with the lowest max Ron value from the channel with the highest max Ron value.

(3) Crosstalk is inversely proportional to source impedance

Typical Performance Curves (Ta=25°C, VCC=3.0V, CAP=0.1uF, unless otherwise noted)

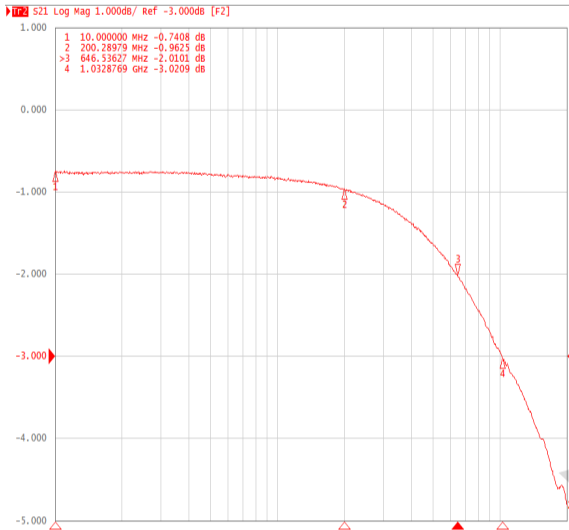

Fig.4 Switch Bandwidth or Insertion Loss

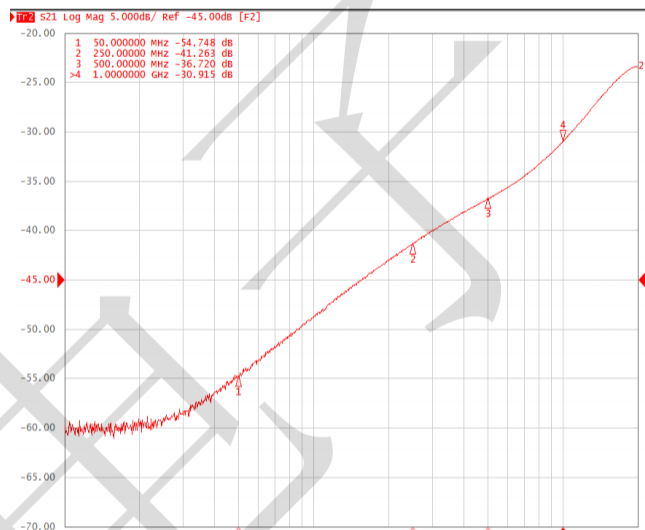

Fig.5 Switch Channel to Channel Cross-Talk

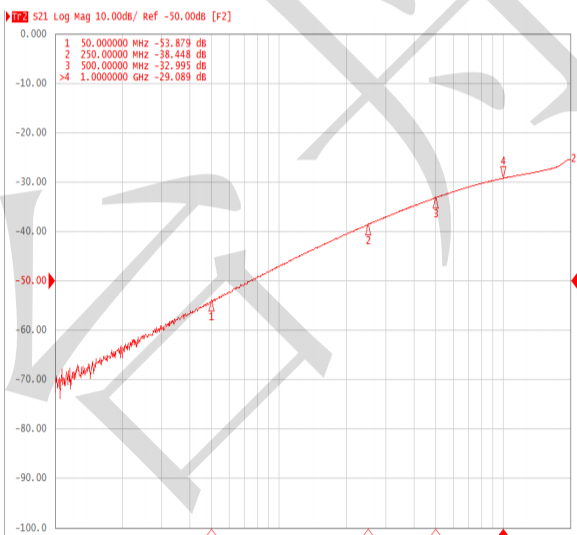
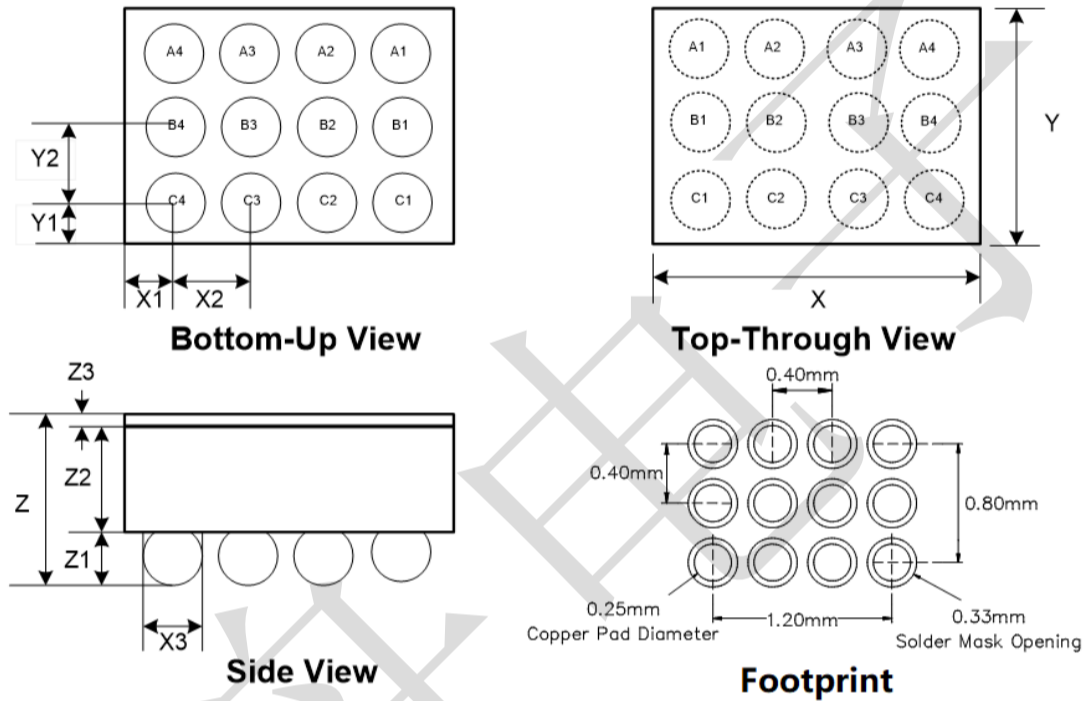

Fig.6 Switch Off Isolation

**Package Outline Dimensions**

**WLCSP-12B**



**Fig-7 Package Outline Dimensions**

| Symbol | Dimensions In Millimeter |       |       |
|--------|--------------------------|-------|-------|
|        | Min.                     | Typ.  | Max.  |
| X      | 1.58                     | 1.6   | 1.62  |
| Y      | 1.18                     | 1.2   | 1.22  |
| X1     |                          | 0.20  |       |
| X2     |                          | 0.40  |       |
| X3     | 0.21                     | 0.23  | 0.25  |
| Y1     |                          | 0.20  |       |
| Y2     |                          | 0.40  |       |
| Z      | 0.525                    | 0.575 | 0.625 |
| Z1     | 0.165                    | 0.185 | 0.205 |
| Z2     | 0.340                    | 0.365 | 0.390 |
| Z3     | 0.020                    | 0.025 | 0.030 |