

Features

- Wide supply voltage range from 1.65 V to 3.6 V
- CMOS low power dissipation
- Overvoltage tolerant inputs to 5.5 V
- Latch-up performance exceeds 250 mA
- Direct interface with TTL levels
- ESD protection:
HBM ANSI/ESDA/JEDEC JS-00
Class 3A exceeds 6000 V
CDM ANSI/ESDA/JEDEC JS-002
Class C3 exceeds 2000 V
- I_{OFF} circuitry provides partial Power-down mode operation
- Complies with JEDEC standard:
JESD8-7 (1.65 V to 1.95 V)
JESD8-5 (2.3 V to 2.7 V)
JESD8C (2.7 V to 3.6 V)
- Packaging: TSSOP-14

General Description

The is a hex inverter. Inputs can be driven from either 2.7V or 3.6V devices. This feature allows the use of these devices as translators in mixed 2.7V and 3.6V environments.

Schmitt-trigger action at all inputs makes the circuit tolerant of slower input rise and fall times. This device is fully specified for partial power down applications using I_{OFF}. The I_{OFF} circuitry disables the output, preventing the potentially damaging backflow current through the device when it is powered down.

PIN CONFIGURATIONS (Top view)

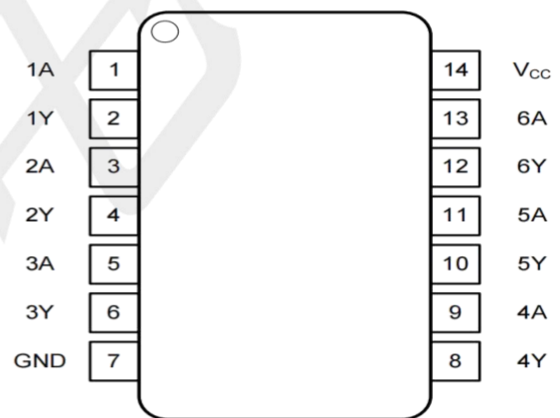

TSSOP-14

PIN DESCRIPTION

PIN NO.	PIN NAME	DESCRIPTION	PIN NO.	PIN NAME	DESCRIPTION
1	1A	Data input	8	4Y	Data output
2	1Y	Data output	9	4A	Data input
3	2A	Data input	10	5Y	Data output
4	2Y	Data output	11	5A	Data input
5	3A	Data input	12	6Y	Data output
6	3Y	Data output	13	6A	Data input
7	GND	ground (0 V)	14	V _{CC}	supply voltage

Functional diagram

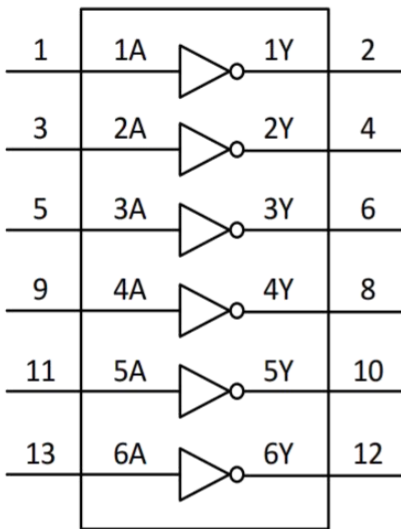

Fig. 1. Logic symbol

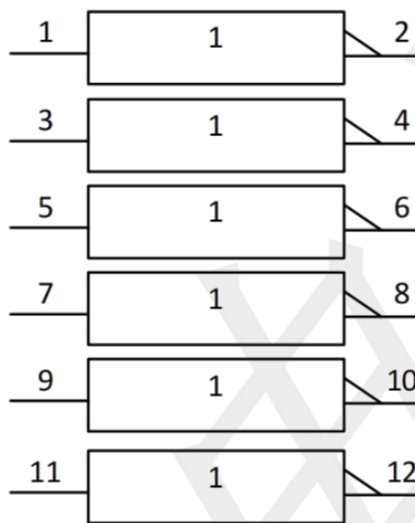

Fig. 2. IEC logic symbol



Fig. 3. Logic diagram (one gate)

Functional Description

Function table

Input nA	Output nY
L	H
H	L

H = HIGH voltage level; L = LOW voltage level

ABSOLUTE MAXIMUM RATINGS

In accordance with the Absolute Maximum Rating System. Voltages are referenced to GND.

Symbol	Parameter	Conditions	Min	Max	Unit
V _{CC}	supply voltage		-0.5	6.5	V
I _{IK}	input clamping current	V _I < 0 V	-50	--	mA
V _I	input voltage	(1)	-0.5	6.5	V
I _{OK}	output clamping current	V _O > V _{CC} or V _O < 0 V	--	±50	mA
V _O	output voltage	Active mode (1)	0	V _{CC} + 0.5	V
		Power-down mode; V _{CC} = 0 V (1)	0	6.5	V
I _O	output current	V _O = 0 V to V _{CC}	--	±50	mA
I _{CC}	supply current		--	100	mA
I _{GND}	ground current		-100	--	mA
P _{tot}	total power dissipation	T _{amb} = -40 °C to + 125 °C	--	500	mW
T _{stg}	storage temperature		-65	150	°C

Note: 1. The input and output voltage ratings may be exceeded if the input and output current ratings are observed.

Recommended operating conditions

Symbol	Parameter	Conditions	Min	Max	Unit
V _{CC}	supply voltage		1.65	3.6	V
		functional	1.2	--	V
V _I	input voltage		0	3.6	V
V _O	output voltage	Active mode	0	V _{CC}	V
		Power-down mode; V _{CC} = 0 V	0	3.6	V
T _{amb}	ambient temperature		-40	125	°C
Δt/ΔV	input transition rise and fall rate	V _{CC} = 1.65 V to 2.7 V	0	20	ns/V
		V _{CC} = 2.7 V to 5.5 V	0	10	ns/V

Static characteristics

(Voltages are referenced to GND (ground=0V), unless otherwise specified.)

Symbol	Parameter	Conditions	-40 °C to +85 °C			-40 °C to +125 °C		Unit
			Min	Typ	Max	Min	Max	
V _{IH}	HIGH-level input voltage	V _{CC} = 1.2 V	1.08	--	--	1.08	--	V
		V _{CC} = 1.65 V to 1.95 V	0.65V _{CC}	--	--	0.65V _{CC}	--	V
		V _{CC} = 2.3 V to 2.7 V	1.7	--	--	1.7	--	V
		V _{CC} = 2.7 V to 3.6 V	2.0	--	--	2.0	--	V
V _{IL}	LOW-level input voltage	V _{CC} = 1.2 V	--	--	0.12	--	0.12	V
		V _{CC} = 1.65 V to 1.95 V	--	--	0.35V _{Cc}	--	0.35V _{CC}	V
		V _{CC} = 2.3 V to 2.7 V	--	--	0.7	--	0.7	V
		V _{CC} = 2.7 V to 3.6 V	--	--	0.8	--	0.8	V
V _{OH}	HIGH-level output voltage	V _I = V _{IH} or V _{IL}						
		I _O = -100 μA; V _{CC} = 1.65 V to 5.5 V	V _{CC} - 0.1	--	--	V _{CC} - 0.1	--	V
		I _O = -4 mA; V _{CC} = 1.65 V	1.2	--	--	1.05	--	V
		I _O = -8 mA; V _{CC} = 2.3 V	1.9	--	--	1.7	--	V
		I _O = -12 mA; V _{CC} = 2.7 V	2.2	--	--	2.05	--	V
		I _O = -24 mA; V _{CC} = 3.0 V	2.4	--	--	2.25	--	V
		I _O = -32 mA; V _{CC} = 3.6 V	3.1	--	--	3.0	--	V
V _{OL}	LOW-level output voltage	V _I = V _{IH} or V _{IL}						
		I _O = 100 μA; V _{CC} = 1.65 V to 5.5 V	--	--	0.10	--	0.10	V
		I _O = 4 mA; V _{CC} = 1.65 V	--	--	0.45	--	0.65	V
		I _O = 8 mA; V _{CC} = 2.3 V	--	--	0.30	--	0.45	V
		I _O = 12 mA; V _{CC} = 2.7 V	--	--	0.40	--	0.60	V
		I _O = 24 mA; V _{CC} = 3.0 V	--	--	0.55	--	0.80	V
		I _O = 32 mA; V _{CC} = 3.6 V	--	--	0.55	--	0.80	V
I _I	input leakage current	V _I = 3.6V or GND; V _{CC} = 0 V to 3.6V	--	±0.1	±5	--	±20	μA

Static characteristics

(Voltages are referenced to GND (ground=0V), unless otherwise specified.)

Symbol	Parameter	Conditions	-40 °C to +85 °C			-40 °C to +125 °C		Unit
			Min	Typ	Max	Min	Max	
I_{OFF}	power-off leakage current	$V_{CC} = 0\text{ V};$ V_I or $V_O = 3.6\text{ V}$	--	± 0.1	± 10	--	± 20	μA
I_{CC}	supply current	$V_{CC} = 1.65\text{ V to } 3.6\text{ V};$ $V_I = V_{CC}$ or GND ; $I_O = 0\text{ A};$	--	0.01	10	--	40	μA
ΔI_{CC}	additional supply current	per input pin ; $V_{CC} = 2.3\text{ V to } 3.6\text{ V};$ $V_I = V_{CC} - 0.6\text{ V}; I_O = 0\text{ A}$	--	0.2	500	--	5000	μA
C_i	input capacitance	$V_{CC} = 3.3\text{ V};$ $V_I = \text{GND to } V_{CC}$	--	4	--	--	--	pF

Note:All typical values are measured at $V_{CC} = 3.3\text{V}$ and $T_{amb} = 25\text{ °C}$.

Dynamic Characteristics

Voltages are referenced to GND (ground = 0 V); for test circuit see

Symbol	Parameter	Conditions	-40 °C to +85 °C			-40 °C to +125 °C		Unit
			Min	Typ	Max	Min	Max	
t_{pd}	propagation delay	nA to nY;						
		$V_{CC} = 1.2\text{ V}$	--	28.3	--	--	--	ns
		$V_{CC} = 1.65\text{ V to } 1.95\text{ V}$	3.5	8.5	16.5	3.5	17	ns
		$V_{CC} = 2.3\text{ V to } 2.7\text{ V}$	2.0	4.8	8.0	2.0	9.0	ns
		$V_{CC} = 3.0\text{ V to } 3.6\text{ V}$	1.5	3.5	5.5	1.5	6.0	ns
$t_{sk(o)}$	output skew time	$V_{CC} = 3.0\text{ V to } 3.6\text{ V}$	--	--	1.0	--	1.5	ns
C_{PD}	power dissipation capacitance	per gate ; $V_I = \text{GND to } V_{CC}$						
		$V_{CC} = 1.65\text{ V to } 1.95\text{ V}$	--	12.7	--	--	--	pF
		$V_{CC} = 2.3\text{ V to } 2.7\text{ V}$	--	13.4	--	--	--	pF
		$V_{CC} = 3.0\text{ V to } 3.6\text{ V}$	--	14.3	--	--	--	pF

Note:Typical values are measured at $T_{amb} = 25\text{ °C}$ and $V_{CC} = 1.2\text{ V}, 1.8\text{ V}, 2.5\text{ V}, 3.3\text{ V}$ and 3.6 V respectively.

Waveforms and test circuit

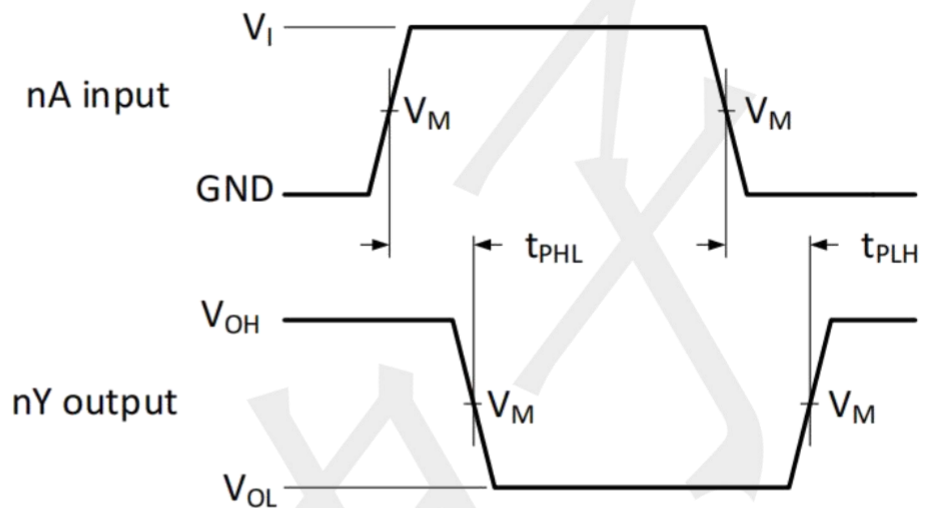

Measurement points are given in Table 8.

V_{OL} and V_{OH} are typical output voltage levels that occur with the output load.

The input nA to output nY propagation delays

Measurement points

Supply voltage	Input	Output
V_{CC}	V_M	V_M
1.2 V	$0.5V_{CC}$	$0.5V_{CC}$
1.65 V to 1.95 V	$0.5V_{CC}$	$0.5V_{CC}$
2.3 V to 2.7 V	$0.5V_{CC}$	$0.5V_{CC}$
3.0 V to 3.6 V	1.5 V	1.5 V

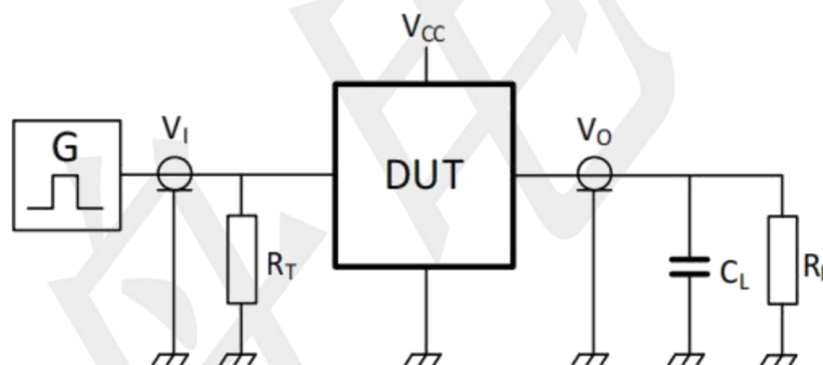
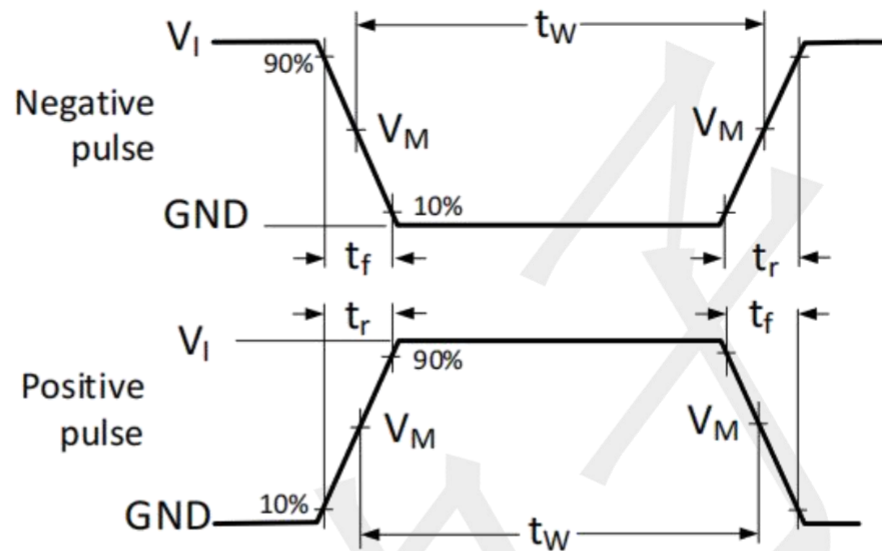

Test data is given in Table 9.

Definitions for test circuit:

R_L = Load resistance.

C_L = Load capacitance including jig and probe capacitance.

R_T = Termination resistance should be equal to the output impedance Z_o of the pulse generator.

Test data

Supply voltage	Input		Load	
V_{CC}	V_I	$t_r = t_f$	C_L	R_L
1.2 V	V_{CC}	≤ 2.0 ns	15 pF	500 Ω
1.65 V to 1.95 V	V_{CC}	≤ 2.0 ns	15 pF	500 Ω
2.3 V to 2.7 V	V_{CC}	≤ 2.0 ns	15 pF	500 Ω
3.0 V to 3.6 V	3 V	≤ 2.0 ns	15 pF	500 Ω

Package information TSSOP-14

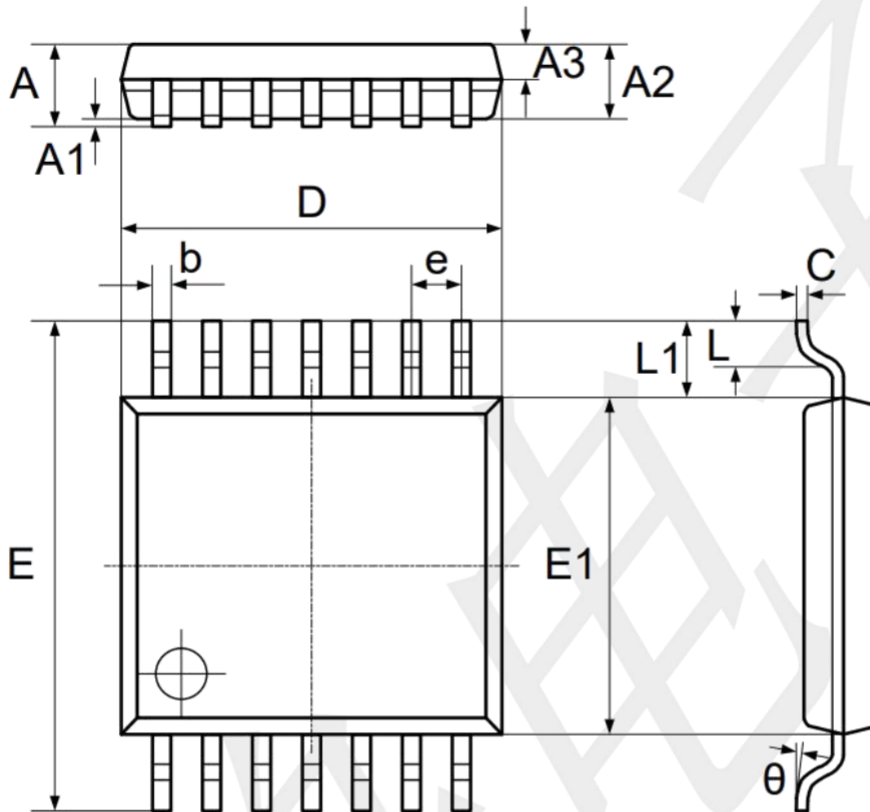

Symbol	Dimensions In Millimeters		Dimensions In Inches	
	Min	Max	Min	Max
A	-	1.200	-	0.047
A1	0.050	0.150	0.002	0.006
A2	0.900	1.050	0.035	0.041
A3	0.390	0.490	0.015	0.019
b	0.200	0.290	0.008	0.011
C	0.130	0.180	0.005	0.007
D	4.860	5.060	0.191	0.199
E	6.200	6.600	0.244	0.260
E1	4.300	4.500	0.169	0.177
e	0.650 TYP.		0.026 TYP.	
L1	1.000 REF.		0.039 REF.	
L	0.450	0.750	0.018	0.030
θ	0°	8°	0°	8°