

REV.	DESCRIPTION	ECN NO.	NAME	DATE

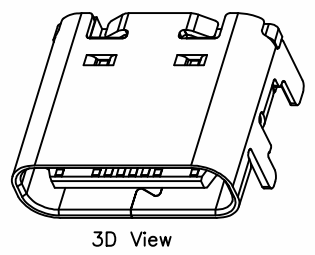

- SPECIFICATION:**
- Material:
    - HOUSING&MOLDING:LCP,UL94 V-0
    - CONTACTS:COPPER ALLOY T=0.20mm
    - MIDDLE CLIP:SUS301-1/2H,T=0.15mm
    - SHELL:SUS, T=0.30mm
  - Mechanical:
    - 2.1.Mating force:5~20Nf Max.;
    - 2.2.Unmating force:6~20Nf Min.;
    - 2.3.Durability:10000 Cycles;
  - Electrical:
    - 3.1.Current Rating:3A Max.;
    - 3.2.Voltage Rating:20V Max.;
    - 3.3.Dielectric Withstanding voltage:100VAc;
    - 3.4.Contact resistance:40m Ohms Max.;
    - 3.5.Insulation Resistance:100M Ohms Min.;
  - Environmental:
    - 4.1.Operating temperature:-40°C~+85°C;
    - 4.2.Wetting Temperature:265±5°C,5±0.5s

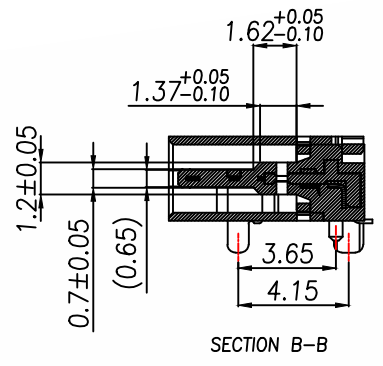
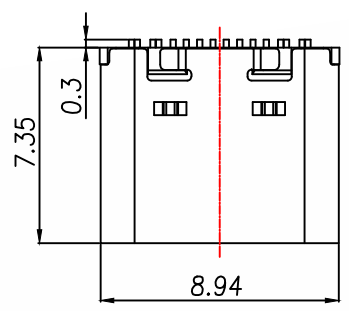
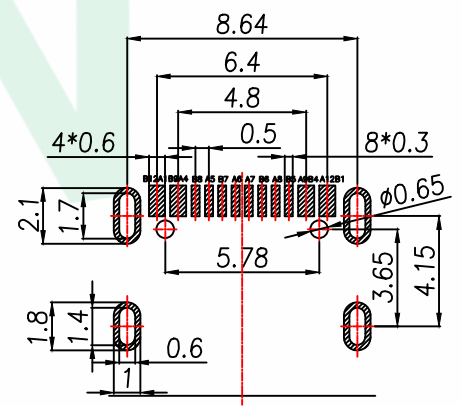
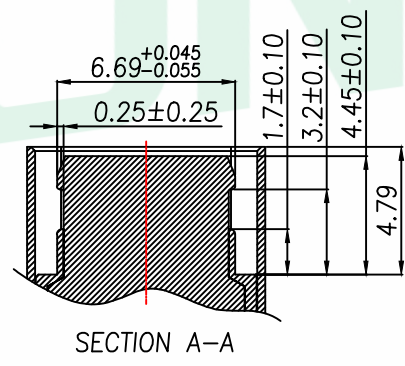
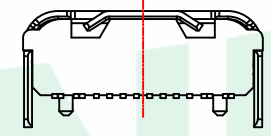
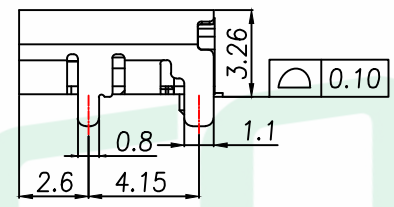
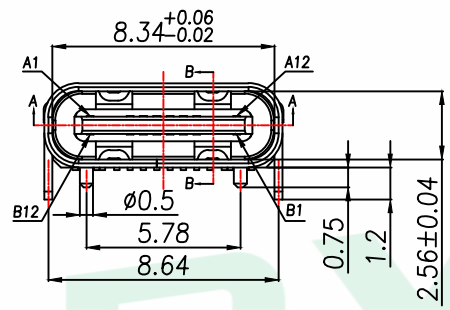

PIN DEFINE TABLE			
PIN	SIGNAL	PIN	SIGNAL
A12	GND	B1	GND
A11		B2	
A10		B3	
A9	VBUS	B4	VBUS
A8	SBU1	B5	CC2
A7	D-	B6	D+
A6	D+	B7	D-
A5	CC1	B8	SBU2
A4	VBUS	B9	VBUS
A3		B10	
A2		B11	
A1	GND	B12	GND

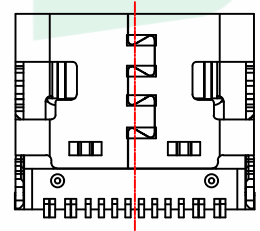

GENERAL TOLERANCE		DONGGUAN BAOXUN PRECISION TECHNOLOGY CO., LTD			
DIM.	TOL.	TITLE: TYPE-C 16pin 母座 板上型 带塑胶柱 DWG. NO.: BX-USB-701-16P PART NO.: BX-USB-701-16P UNIT: mm    SCALE: none    SHEET: 1 of 1    DWG. SIZE: A4    LAYER: bxconn CHECKED: MAX DRAWN: ELLA APPROVED: WILL			
x.	±0.35				
x.x	±0.25				
x.xx	±0.15				
GENERAL ANGLE:					
x.°	±3.0°				
x.x°	±2.5°				
x.xx°	±2.0°				



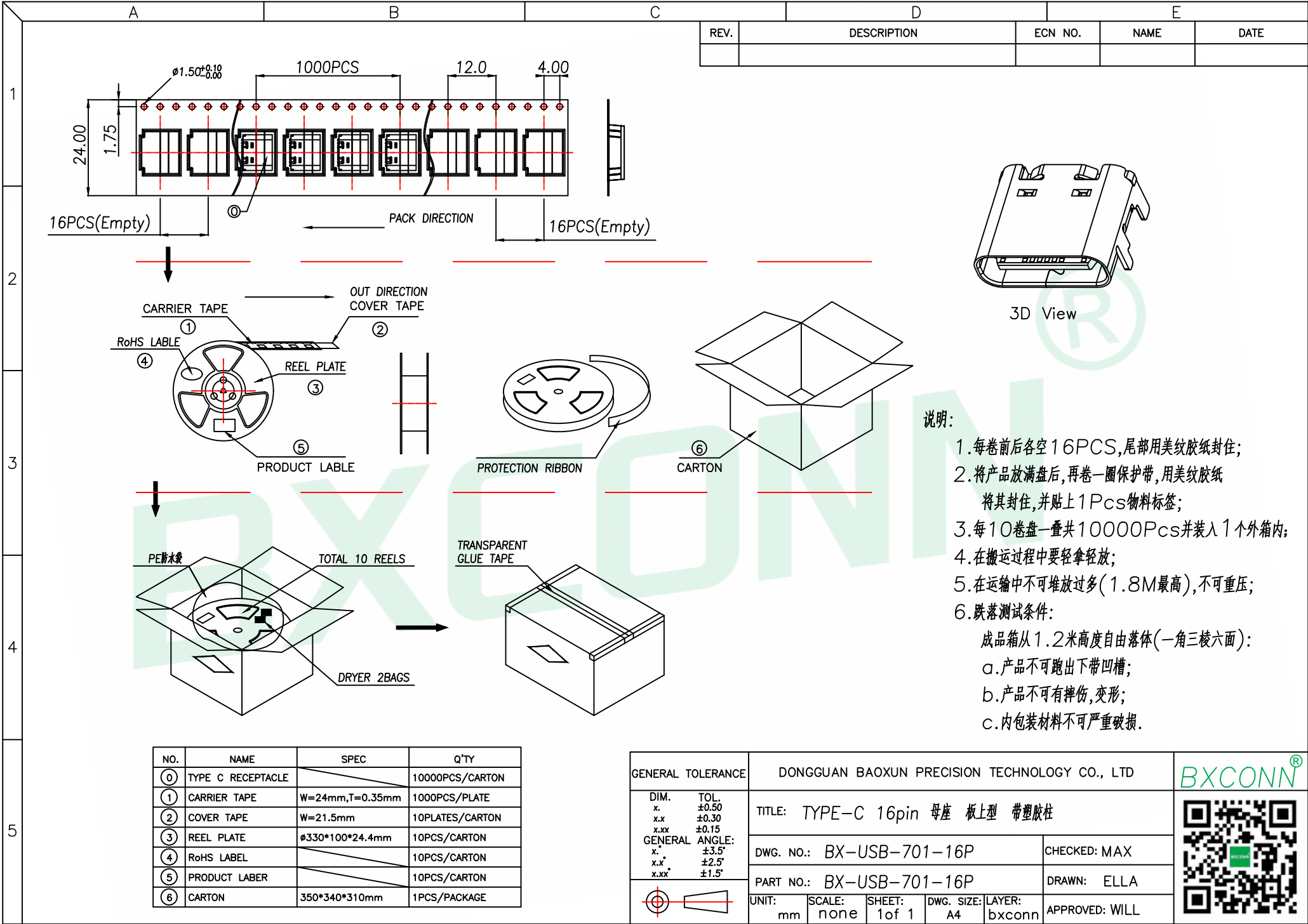

REV.	DESCRIPTION	ECN NO.	NAME	DATE

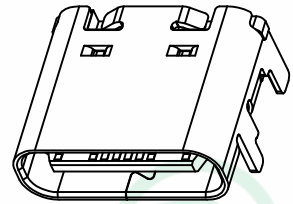

3D View

说明:

1. 每卷前后各空16PCS,尾部用美纹胶纸封住;
2. 将产品放满盘后,再卷一圈保护带,用美纹胶纸将其封住,并贴上1Pcs物料标签;
3. 每10卷盘一叠共10000Pcs并装入1个外箱内;
4. 在搬运过程中要轻拿轻放;
5. 在运输中不可堆放过多(1.8M最高),不可重压;
6. 跌落测试条件:  
成品箱从1.2米高度自由落体(一角三棱六面):  
a. 产品不可跑出下带凹槽;  
b. 产品不可有摔伤,变形;  
c. 内包装材料不可严重破损.

NO.	NAME	SPEC	Q'TY
⑥	TYPE C RECEPTACLE		10000PCS/CARTON
①	CARRIER TAPE	W=24mm,T=0.35mm	1000PCS/PLATE
②	COVER TAPE	W=21.5mm	10PLATES/CARTON
③	REEL PLATE	φ330*100*24.4mm	10PCS/CARTON
④	RoHS LABEL		10PCS/CARTON
⑤	PRODUCT LABER		10PCS/CARTON
⑥	CARTON	350*340*310mm	1PCS/PACKAGE

GENERAL TOLERANCE	DONGGUAN BAOXUN PRECISION TECHNOLOGY CO., LTD	
DIM. TOL. x. ±0.50 x.x ±0.30 x.xx ±0.15 GENERAL ANGLE: x.° ±3.5° x.x° ±2.5° x.xx° ±1.5°	TITLE: TYPE-C 16pin 母座 板上型 带塑胶柱	
	DWG. NO.: BX-USB-701-16P	CHECKED: MAX
	PART NO.: BX-USB-701-16P	DRAWN: ELLA
	UNIT: mm	SCALE: none
	DWG. SIZE: A4	LAYER: bxconn
	APPROVED: WILL	

