

“*” Pivot Dimension

RoHS Component

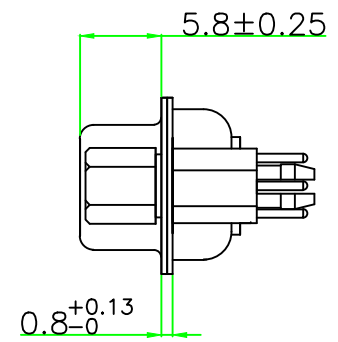
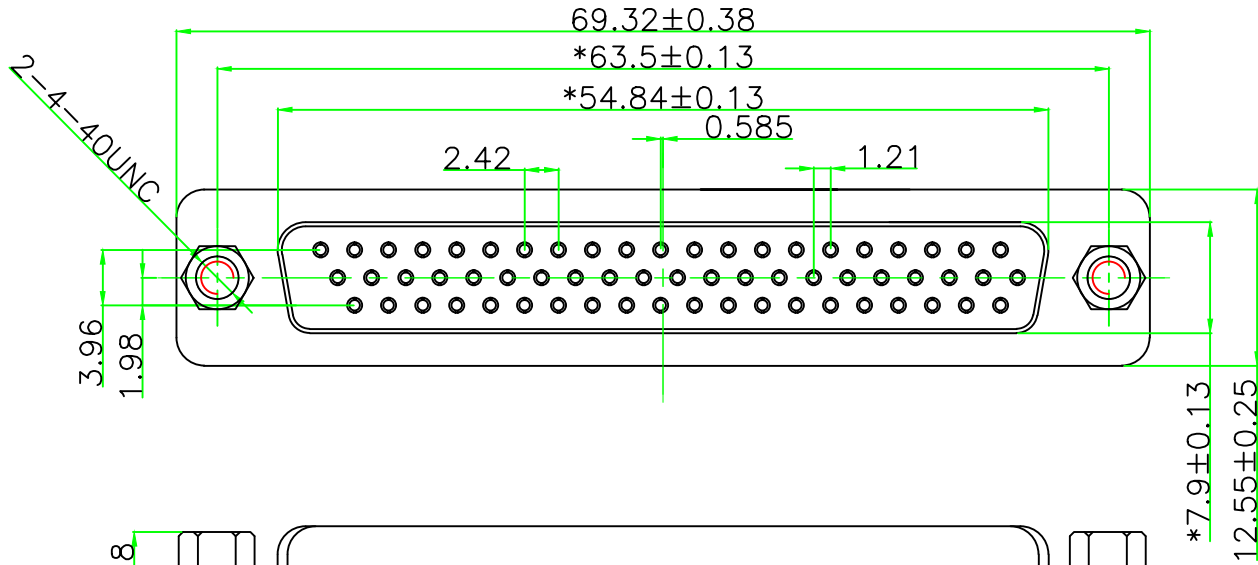

NOTICE :

1. ELECTRIC:
 - DIELECTRIC RATING: 300V
 - CONTACT CURRENT RATING: 3AMP
 - CONTACT RESISTANCE: 15mΩ MAX.
 - INSULATION RESISTANCE: 1000MΩ MIN. AT 500V DC
 - DIELECTRIC STRENGTH: 500V AC RMS FOR 1MINUTE
 - OPERATION TEMPERATURE: -55C° ~125C°
2. MATERIAL:
 - INSULATOR: PBT+30% G.F (UL94V-0)
 - CONTACT: COPPER ALLOY
 - CONTACT PLATED: GOLD FIASH OVER NICKEL
 - SHELL: SPCC
 - SHELL PLATED: NICKEL/TIN
 - FORK: COPPER ALLOY/PLATED NICKEL

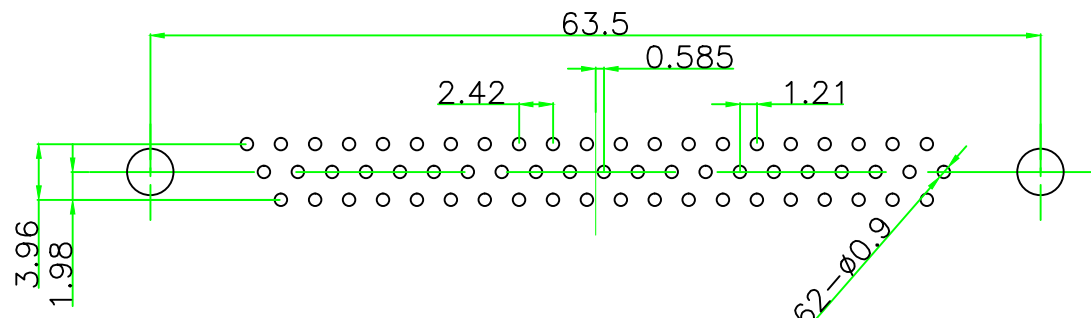
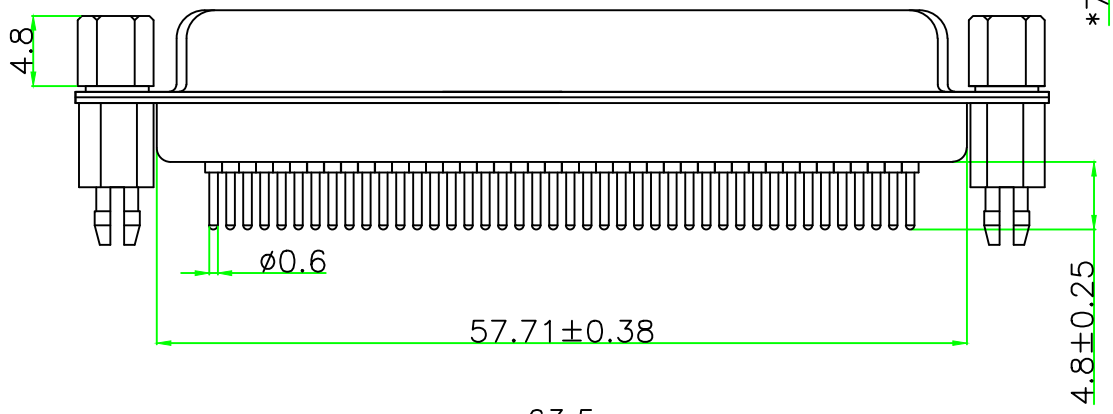

PCB LAYOUT

浙江创都电子科技有限公司

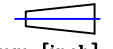
TOLERANCE: XX ±0.38 XXX ±0.25 XXXX ±0.13 X* ±5° X.X* ±1°	DRAWN BY : _____	DATE : 2009.12.16	PART NAME: QH HDP 62 母 直焊板式铆6.0鱼叉锁4.8螺丝
	CHECKED BY: _____	DATE : 2014.11.05	DRAW NO. HDP-M-62P-ZC-YCLS PART NO.
 	APPROVED BY: _____	DATE : 2014.11.05	REMARK _____ MOLD NO.
UNIT: mm [inch]	SCALE: 1:1	A版	