

Product Summary

- V_{DS} 30V
- I_D 4A
- $R_{DS(ON)}$ ($V_{GS}=10V$) $\leq 70m\Omega$
- ESD protected gate typical

Application

- Interfacing Switching
- Load Switch
- Portable equipment and battery
- DC/DC Converter

Package and Pin Configuration

1. GATE
2. SOURCE
3. DRAIN

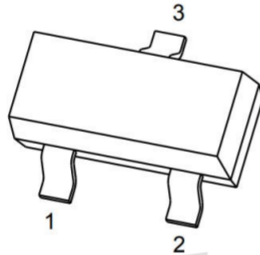

SOT-23

Circuit diagram

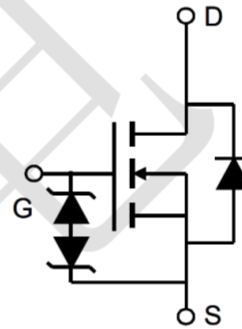

Absolute Maximum Ratings ($T_A=25^\circ C$ unless otherwise noted)

PARAMETER	SYMBOL	LIMIT	UNIT
Drain-Source Voltage	V_{DS}	30	V
Gate-Source Voltage	V_{GS}	± 20	V
Continuous Drain Current	I_D	4	A
Pulsed Drain Current ($t = 100 \mu s$)	I_{DM}	20	A
Electrostatic Discharge Rating Human Body Model	ESD	2.0	KV
Maximum Power Dissipation	P_D	1.0	W
Operating Junction Temperature Range	T_J	+155	$^\circ C$
Storage Temperature Range	T_{stg}	-55 to +150	$^\circ C$

Thermal Characteristic

PARAMETER	Symbol	Value	Unit
Thermal Resistance from Junction to Ambient($t \leq 10s$)	$R_{\theta JA}$	170	$^\circ C/W$
	PCB Mount (Note)		

Note : When mounted on 1" square PCB (FR4 material).

Electrical Characteristics ($T_A=25^\circ\text{C}$ unless otherwise noted)

PARAMETER	CONDITIONS	SYMBOL	MIN	TYP	MAX	UNIT
Static						
Drain-Source Breakdown Voltage	$V_{GS}=0V, I_D=250\mu A$	BV_{DSS}	30	--	--	V
Gate-Source Threshold Voltage	$V_{DS}=V_{GS}, I_D=250\mu A$	$V_{GS(th)}$	1.0	1.5	2.0	V
Gate-Source Leakage	$V_{DS}=0V, V_{GS}=\pm 20V$	I_{GSS}	--	--	± 10	μA
Zero Gate Voltage Drain Current	$V_{DS}=25V, V_{GS}=0V$	I_{DSS}	--	--	1.0	μA
Drain-Source On-State Resistance (Note 1)	$V_{GS}=10V, I_D=6A$	$R_{DS(on)}$	--	50	70	m Ω
Forward Transconductance (Note 2)	$V_{DS}=5V, I_D=5A$	g_{fs}	--	20	--	S
Dynamic (Note 2)						
Input Capacitance	$V_{DS}=15V, V_{GS}=0V,$ $F=1.0MHz$	C_{iss}	--	480	--	pF
Output Capacitance		C_{oss}	--	120	--	
Reverse Transfer Capacitance		C_{rss}	--	32	--	
Switching						
Turn-On Delay Time (Note 3)	$V_{DS}=15V,$ $I_D=5A,$ $V_{GEN}=10V,$ $R_G=3\Omega$	$t_{d(on)}$	--	12	--	nS
Rise Time (Note 3)		t_r	--	46	--	
Turn-Off Delay Time (Note 3)		$t_{d(off)}$	--	25	--	
Fall Time (Note 3)		t_f	--	9	--	
Total Gate Charge	$V_{DS}=15V,$ $I_D=5A,$ $V_{GS}=10V$	Q_g	--	12	--	nC
Gate-Source Charge		Q_{gs}	--	1.8	--	
Gate-Drain Charge		Q_{gd}	--	3.1	--	
Source-Drain Diode Ratings and Characteristics (Note 2)						
Forward Voltage	$V_{GS}=0V, I_F=1A$	V_{SD}	--	0.85	1.2	V
Continuous Source Current	Integral reverse diode in the MOSFET	I_S	--	--	4	A
Pulsed Current (Note 1)		I_{SM}	--	--	20	A

Notes:

1. Pulse test; pulse width $\leq 300 \mu s$, duty cycle $\leq 2\%$.
2. Guaranteed by design, not subject to production testing.
3. Independent of operating temperature

TYPICAL CHARACTERISTICS (25 °C, unless otherwise noted)

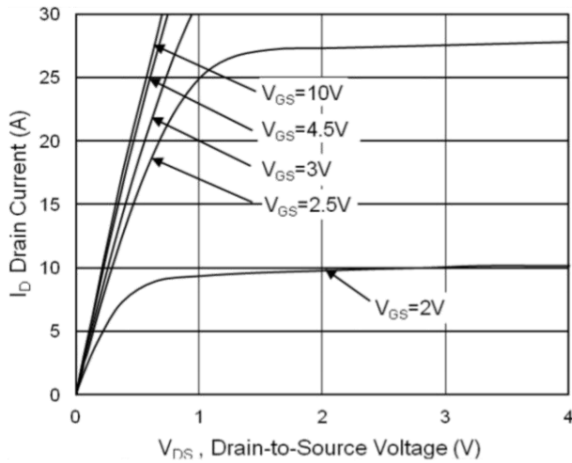

Fig.1 Typical Output Characteristics

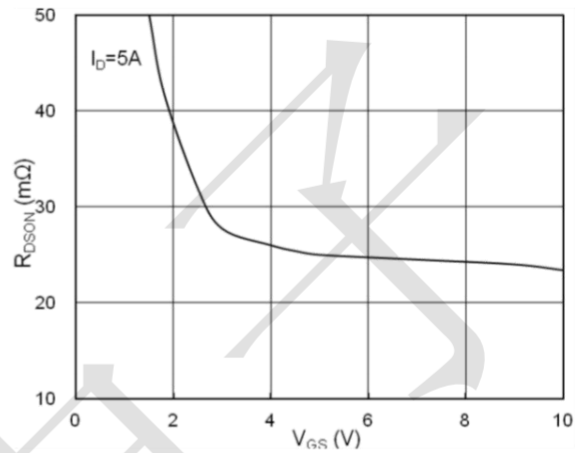

Fig.2 On-Resistance vs. Gate-Source

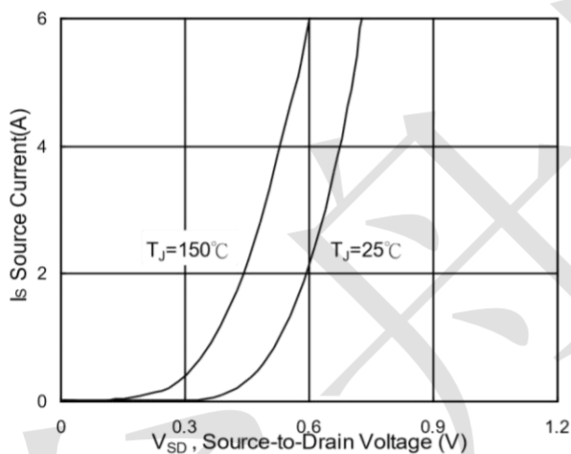

Fig.3 Forward Characteristics Of Reverse

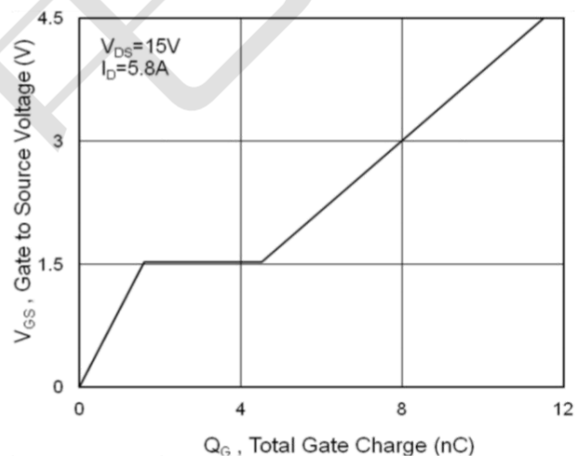

Fig.4 Gate-Charge Characteristics

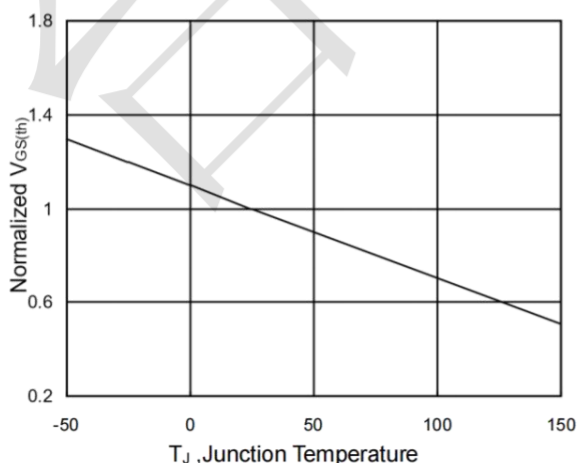

Fig.5 Normalized $V_{GS(th)}$ vs. T_J

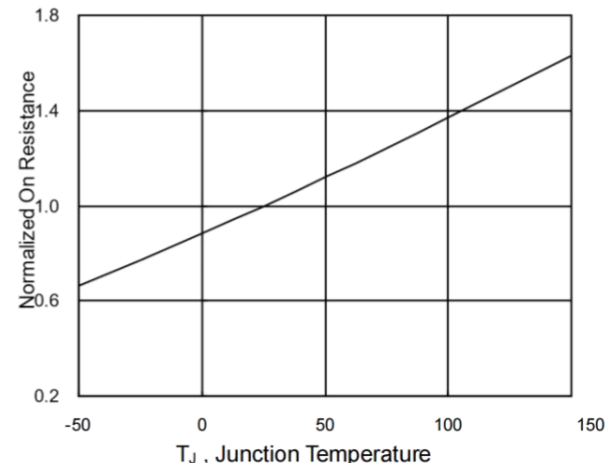
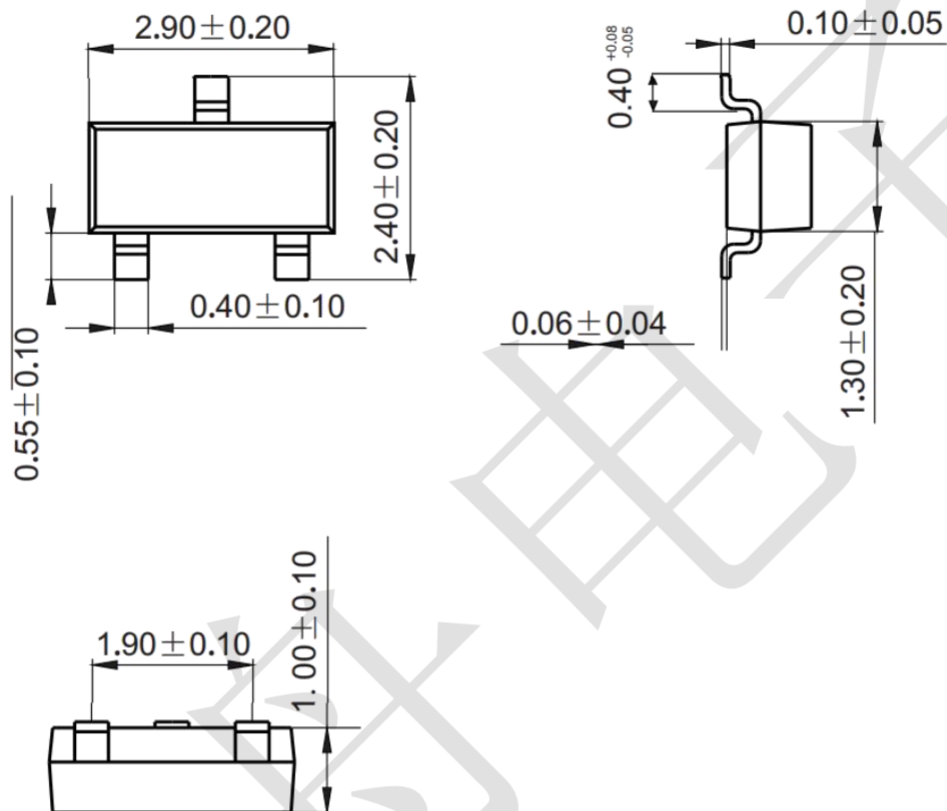

Fig.6 Normalized $R_{DS(on)}$ vs. T_J

Package Outline Dimensions (unit: mm)

SOT-23



Mounting Pad Layout (unit: mm)

