

REV.	DESCRIPTION	ECN NO.	NAME	DATE

NOTE:

1.MATERIAL SPECIFICATION:

- 1.HOUSING:HIGH TEMPERATURE RESISTANT PLASTIC,UL94 V-0.
- 2.TERMINAL: COPPER ALLOY(C1815)
- 3.MID PLATE: STAINLESS STEEL(SUS301)
- 4.FRONT SHELL: STAINLESS STEEL(SUS304)

2.PLATING SPECIFICATION:

2-1.TERMINAL:

- Ni 50u" MIN. UNDER PLATED OVER ALL.
- Au PLATED ON THE FUNCTIONAL AREA OF CONTACT.
- CONTACT FUNCTIONAL AREA PLATED : Au G/F
- CONTACT SOLDER AREA PLATED : Au G/F

2-2.FRONT SHELL:

- Ni 30u" MIN. UNDER PLATED OVER ALL.

2-3.MID PLATE:

- CLEAR ONLY

3.MECHANICAL PERFORMANCE,

- 3-1.INSERTION FORCE: 0.5~2.0kgf.
- 3-2.REMOVAL FORCE: 0.8kgf~2.0kgf.
- 3-3.DURABILITY: 10000 CYCLES.

4.ELECTRICAL PERFORMANCE,

- 4-1. VOLTAGE RATING:5 V DC/AC (RMS. max)
- CURRENT RATING:5 AMPS. FOR TOTAL VBUS/GND PINS;
- 1.25AMPS FOR CC PIN,0.25 AMPS. FOR ALL OTHER CONTACT.
- 4-2. LLCR:
- VBUS & GND PINS AND OTHER PINS: 40mA/PIN MAX.
- LLCR MAX. CHANGE OF ALL PINS: 10mA.
- 4-3.INSULATION RESISTANCE: 100MΩ MIN
- 4-4.DIELECTRIC WITHSTAND VOLTAGE,AC 100V FOR 1 MINUTE.

5. ENVIRONMENTAL PERFORMANCE:

- OPERATING TEMPERATURE: -40°C~+85°C.

6.IR REFLOW:

- THE PEAK TEMPERATURE ON THE BOARD SHALL BE MAINTAINED FOR 10 SECONDS AT 260°C.

A

B

C

D

E

REV.	DESCRIPTION	ECN NO.	NAME	DATE

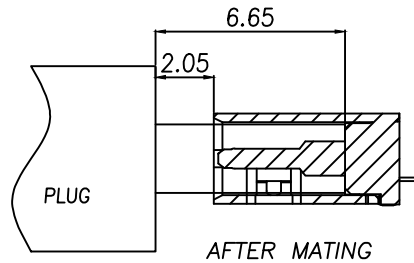

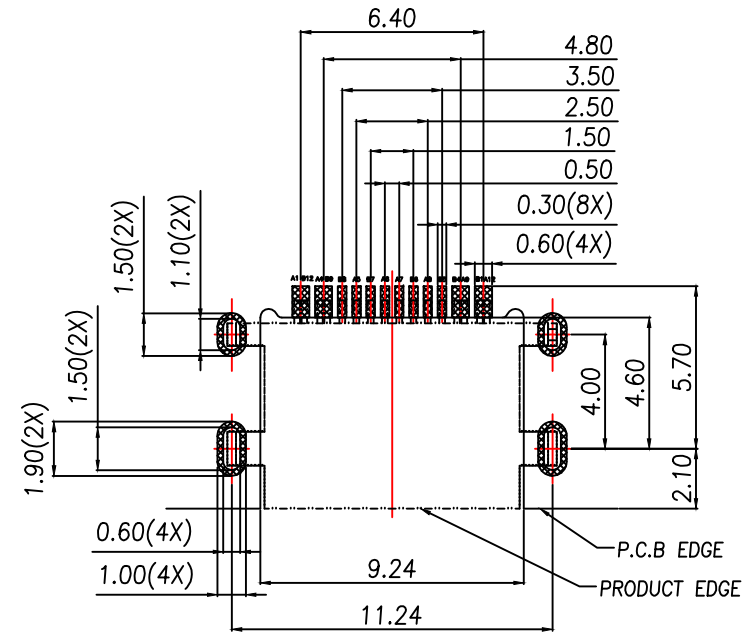

### USB TYPE-C PIN ASSIGNMENTS

PIN NUMBER	SIGNAL NAME	PIN NUMBER	SIGNAL NAME
A1	GND	B12	GND
A4	VBUS	B9	VBUS
A5	CC1	B8	SBU2
A6	Dp1	B7	Dn2
A7	Dn1	B6	Dp2
A8	SBU1	B5	CC2
A9	VBUS	B4	VBUS
A12	GND	B1	GND



RECOMMENDED PCB LAYOUT(TOP VIEW)  
THICKNESS 0.80MM;DEFAULT TOLERANCE:±0.05

GENERAL TOLERANCE		DONGGUAN BAOXUN PRECISION TECHNOLOGY CO., LTD				 
DIM.	TOL.	TITLE: USB CF 16PIN (L=6.5) MID MOUNT 1.6MM				
.x	±0.30	DWG. NO.: TYPE-C-16P-CB-5A		CHECKED: MAX		
.xx	±0.20	PART NO.: TYPE-C-16P-CB-5A		DRAWN: ELLA		
.xxx	±0.10	UNIT: mm		SCALE: none	SHEET: 1 of 1	
GENERAL ANGLE:		DWG. SIZE: A4	LAYER: bxconn	APPROVED: WILL		
x.°	±8°					
x.x°	±5°					
x.xx°						

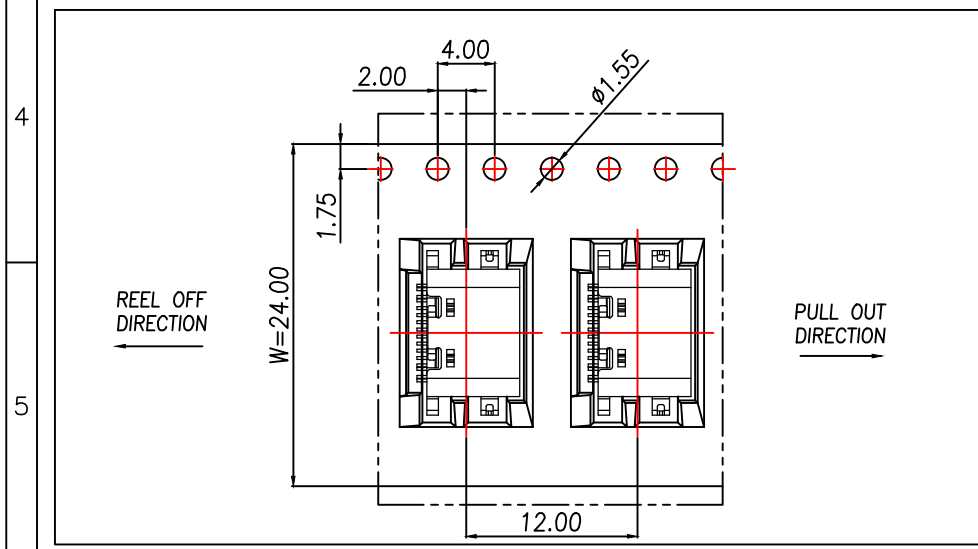
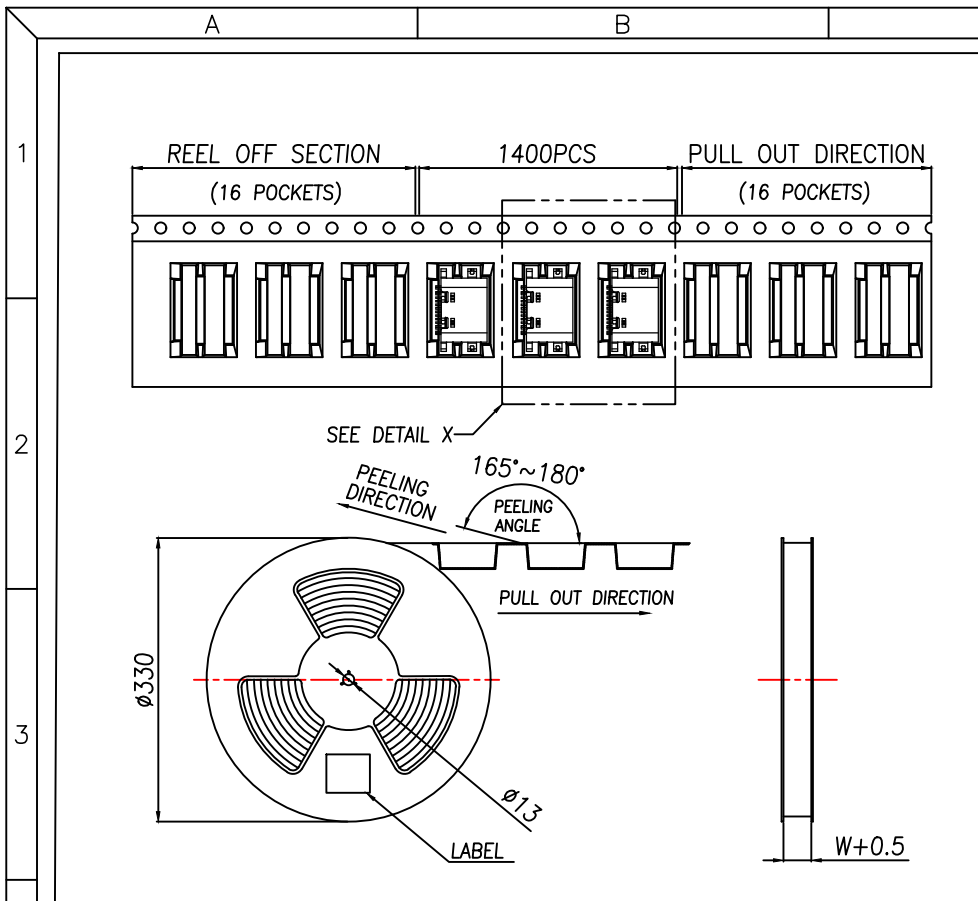

REV.	DESCRIPTION	ECN NO.	NAME	DATE

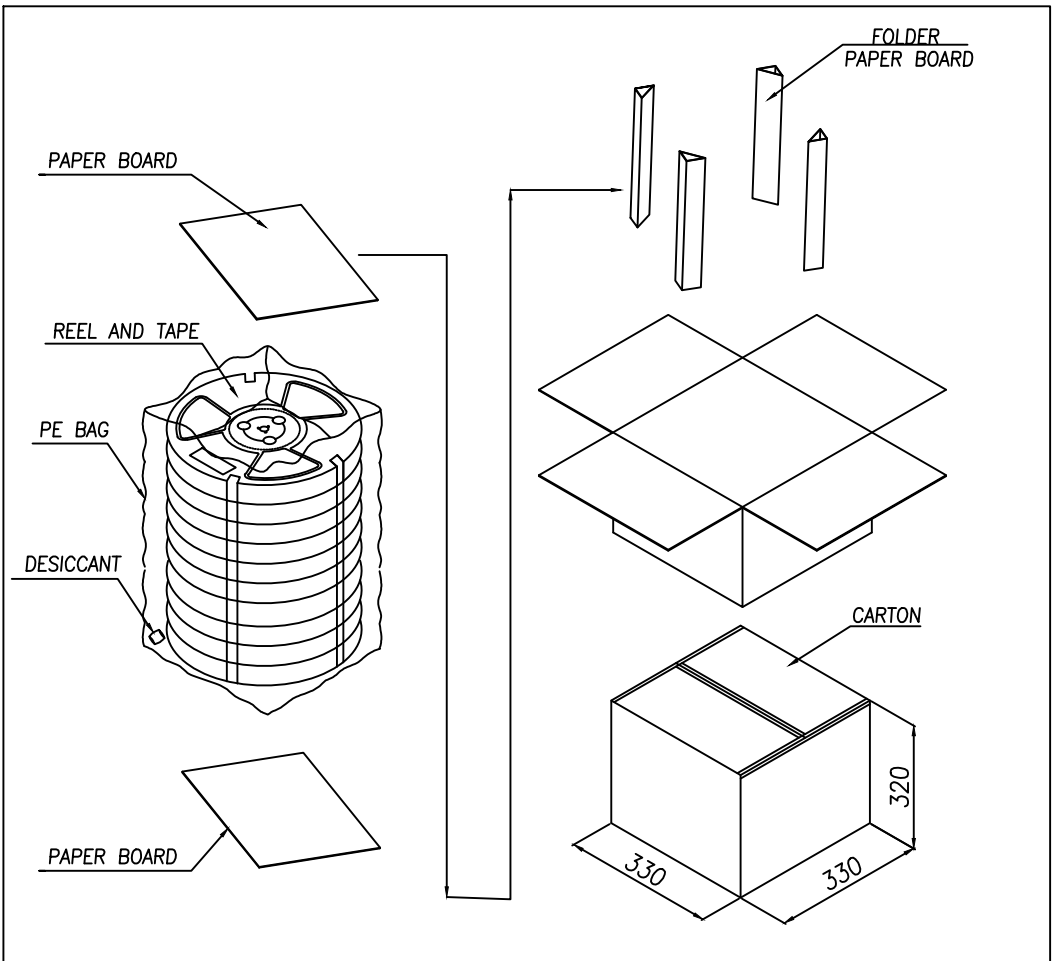

	REEL	CARTON
CONNECTOR (PCS)	1400	14000

GENERAL TOLERANCE	DONGGUAN BAOXUN PRECISION TECHNOLOGY CO., LTD			
DIM.	TOL.	TITLE: USB CF 16PIN (L=6.5) MID MOUNT 1.6MM		
.x	±0.30	DWG. NO.:	TYPE-C-16P-CB-5A	CHECKED: MAX
.xx	±0.20	PART NO.:	TYPE-C-16P-CB-5A	DRAWN: ELLA
.xxx	±0.10	UNIT:	mm	SCALE: none
GENERAL ANGLE:	±8°	SHEET:	1 of 1	DWG. SIZE: A4
x.°	±5°	LAYER:	bxconn	APPROVED: WILL
x.x°				
x.xx°				

