

Features

- Wide supply voltage range from 1.65 V to 3.6 V
- CMOS low power dissipation
- Overvoltage tolerant inputs to 5.5 V
- Latch-up performance exceeds 250 mA
- Direct interface with TTL levels
- ESD protection:
HBM ANSI/ESDA/JEDEC JS-00
Class 3A exceeds 6000 V
CDM ANSI/ESDA/JEDEC JS-002
Class C3 exceeds 2000 V
- I_{OFF} circuitry provides partial Power-down mode operation
- Complies with JEDEC standard:
JESD8-7 (1.65 V to 1.95 V)
JESD8-5 (2.3 V to 2.7 V)
JESD8C (2.7 V to 3.6 V)
- Packaging: TSSOP-14

General Description

The is a quad buffer/line driver with 3-state outputs controlled by the output enable inputs (\overline{nOE}). A HIGH on \overline{nOE} causes the outputs to assume a high impedance OFF-state. Inputs can be driven from either 2.7 V or 3.3 V devices. This feature allows the use of these devices as translators in mixed 2.7 V and 3.3 V environments.

Schmitt-trigger action at all inputs makes the circuit tolerant of slower input rise and fall times. This device is fully specified for partial power down applications using I_{OFF}.

PIN CONFIGURATIONS (Top view)

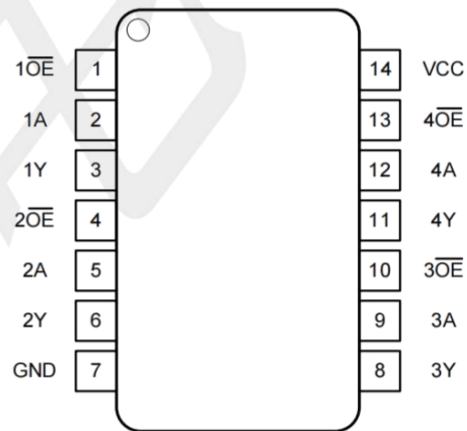

TSSOP-14

PIN DESCRIPTION

PIN NO.	PIN NAME	DESCRIPTION	PIN NO.	PIN NAME	DESCRIPTION
1	$\overline{1OE}$	Data enable input(active LOW)	8	3Y	Data output
2	1A	Data input	9	3A	Data input
3	2Y	Data output	10	$\overline{3OE}$	Data enable input(active LOW)
4	$\overline{2OE}$	Data enable input(active LOW)	11	4Y	Data output
5	2A	Data input	12	4A	Data input
6	2Y	Data output	13	$\overline{4OE}$	Data enable input(active LOW)
7	GND	ground (0 V)	14	V _{CC}	supply voltage

Functional diagram

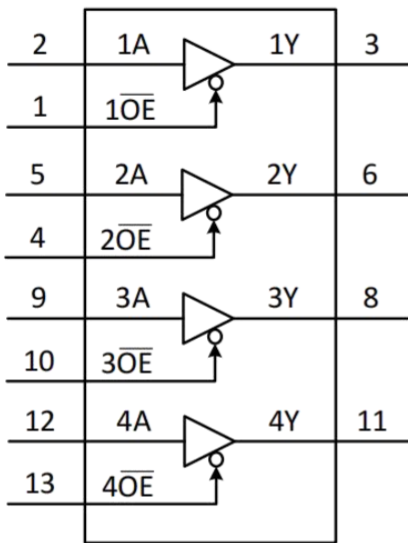

Fig. 1. Logic symbol

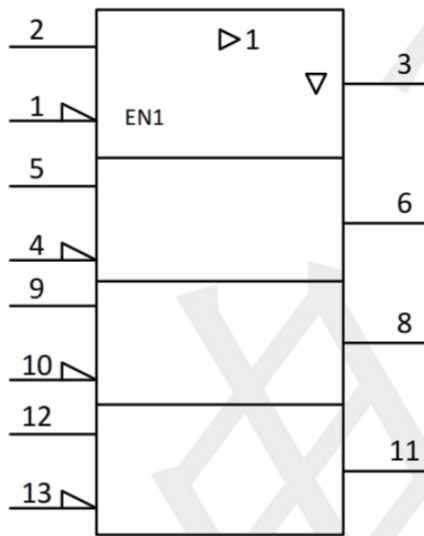

Fig. 2. IEC logic symbol

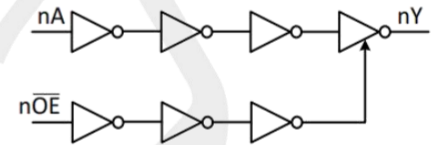

Fig. 3. Logic diagram(one gate)

Functional Description

Function table

Input		Output
\overline{nOE}	nA	nY
L	L	L
L	H	H
H	X	Z

H = HIGH voltage level; L = LOW voltage level; X = don't care; Z = high-impedance OFF-state.

SN74LVC125APWR-TP

Quad Bus Bufferwith 3-State Control Inputs

WWW.TECHPUBLIC.COM

ABSOLUTE MAXIMUM RATINGS

In accordance with the Absolute Maximum Rating System. Voltages are referenced to GND.

Symbol	Parameter	Conditions	Min	Max	Unit
V _{CC}	supply voltage		-0.5	6.5	V
I _{IK}	input clamping current	V _I < 0 V	-50	--	mA
V _I	input voltage	(1)	-0.5	6.5	V
I _{OK}	output clamping current	V _O > V _{CC} or V _O < 0 V	--	±50	mA
V _O	output voltage	Active mode (1)	0	V _{CC} + 0.5	V
		Power-down mode; V _{CC} = 0 V (1)	0	6.5	V
I _O	output current	V _O = 0 V to V _{CC}	--	±50	mA
I _{CC}	supply current		--	100	mA
I _{GND}	ground current		-100	--	mA
P _{tot}	total power dissipation	T _{amb} = -40 °C to + 125 °C	--	500	mW
T _{stg}	storage temperature		-65	150	°C

Note:1. The input and output voltage ratings may be exceeded if the input and output current ratings are observed.

Recommended operating conditions

Symbol	Parameter	Conditions	Min	Max	Unit
V _{CC}	supply voltage		1.65	3.6	V
		functional	1.2	--	V
V _I	input voltage		0	3.6	V
V _O	output voltage	Active mode	0	V _{CC}	V
		Power-down mode; V _{CC} = 0 V	0	3.6	V
T _{amb}	ambient temperature		-40	125	°C
Δt/ΔV	Input transition rise and fall rate	V _{CC} = 1.65 V to 2.7 V	0	20	ns/V
		V _{CC} = 2.7 V to 5.5 V	0	10	ns/V

SN74LVC125APWR-TP

Quad Bus Bufferwith 3-State Control Inputs

WWW.TECHPUBLIC.COM

Static characteristics

At recommended operating conditions. Voltages are referenced to GND (ground = 0 V).

Symbol	Parameter	Conditions	-40 °C to +85 °C			-40 °C to +125 °C		Unit
			Min	Typ	Max	Min	Max	
V _{IH}	HIGH-level input voltage	V _{CC} = 1.2 V	1.08	--	--	1.08	--	V
		V _{CC} = 1.65 V to 1.95 V	0.65V _{CC}	--	--	0.65V _{CC}	--	V
		V _{CC} = 2.3 V to 2.7 V	1.7	--	--	1.7	--	V
		V _{CC} = 2.7 V to 3.6 V	2.0	--	--	2.0	--	V
V _{IL}	LOW-level input voltage	V _{CC} = 1.2 V	--	--	0.12	--	0.12	V
		V _{CC} = 1.65 V to 1.95 V	--	--	0.35V _{CC}	--	0.35V _{CC}	V
		V _{CC} = 2.3 V to 2.7 V	--	--	0.7	--	0.7	V
		V _{CC} = 2.7 V to 3.6 V	--	--	0.8	--	0.8	V
V _{OH}	HIGH-level output voltage	V _I = V _{IH} or V _{IL}						
		I _O = -100μA; V _{CC} = 1.65 V to 3.6 V	V _{CC} - 0.1	--	--	V _{CC} - 0.1	--	V
		I _O = -4 mA; V _{CC} = 1.65 V	1.2	--	--	1.05	--	V
		I _O = -8 mA; V _{CC} = 2.3 V	1.9	--	--	1.7	--	V
		I _O = -12 mA; V _{CC} = 2.7 V	2.2	--	--	2.05	--	V
		I _O = -24 mA; V _{CC} = 3.0 V	2.4	--	--	2.25	--	V
V _{OL}	LOW-level output voltage	V _I = V _{IH} or V _{IL}						
		I _O = 100μA; V _{CC} = 1.65 V to 3.6 V	--	--	0.10	--	0.10	V
		I _O = 4 mA; V _{CC} = 1.65 V	--	--	0.45	--	0.65	V
		I _O = 8 mA; V _{CC} = 2.3 V	--	--	0.30	--	0.45	V
		I _O = 12 mA; V _{CC} = 2.7 V	--	--	0.40	--	0.60	V
		I _O = 24 mA; V _{CC} = 3.0 V	--	--	0.55	--	0.80	V
I _I	Input leakage current	V _I = 3.6 V or GND ; V _{CC} = 0 V to 3.6 V	--	±0.1	±5	--	±20	μA

Static characteristics

At recommended operating conditions. Voltages are referenced to GND (ground = 0 V).

Symbol	Parameter	Conditions	-40 °C to +85 °C			-40 °C to +125 °C		Unit
			Min	Typ	Max	Min	Max	
I_{OZ}	OFF-state output current	$V_I = V_{IH}$ or V_{IL} ; $V_{CC} = 3.6V$; $V_O = 5.5V$ or GND	--	± 0.1	± 5	--	± 20	μA
I_{OFF}	power-off leakage current	$V_{CC} = 0V$; V_I or $V_O = 3.6 V$	--	± 0.1	± 10	--	± 20	μA
I_{CC}	supply current	$V_I = 3.6V$ or GND ; $I_O = 0A$; $V_{CC} = 1.65V$ to $3.6V$	--	0.01	10	--	40	μA
ΔI_{CC}	additional supply current	per input pin ; $V_{CC} = 2.3V$ to $3.6V$; $V_I = V_{CC} - 0.6V$; $I_O = 0A$	--	0.2	500	--	5000	μA
C_i	input capacitance	$V_{CC} = 3.3V$; $V_I = GND$ to V_{CC}	--	4	--	--	--	pF

Note:All typical values are measured at $V_{CC} = 3.3V$ and $T_{amb} = 25\text{ }^\circ C$.

Dynamic Characteristics

Voltages are referenced to GND (ground = 0 V); for test circuit see

Symbol	Parameter	Conditions	-40 °C to +85 °C			-40 °C to +125 °C		Unit
			Min	Typ	Max	Min	Max	
t_{pd}	propagation delay	nA to nY;						
		$V_{CC} = 1.2 V$	--	25	--	--	--	ns
		$V_{CC} = 1.65 V$ to $1.95 V$	3.0	7.9	16.2	3.0	16.5	ns
		$V_{CC} = 2.3 V$ to $2.7 V$	2.2	4.4	8.0	2.2	8.6	ns
		$V_{CC} = 3.0 V$ to $3.6 V$	1.5	3.4	5.8	1.5	6.0	ns

Dynamic Characteristics

Voltages are referenced to GND (ground = 0 V); for test circuit see

Symbol	Parameter	Conditions	-40 °C to +85 °C			-40 °C to +125 °C		Unit
			Min	Typ	Max	Min	Max	
t_{en}	enable time	$\overline{\text{nOE}}$ to nY						
		$V_{CC} = 1.2 \text{ V}$	--	25	--	--	--	ns
		$V_{CC} = 1.65 \text{ V to } 1.95 \text{ V}$	3.0	8.0	15.5	3.0	15.7	ns
		$V_{CC} = 2.3 \text{ V to } 2.7 \text{ V}$	2.2	4.8	8.0	2.2	8.2	ns
		$V_{CC} = 3.0 \text{ V to } 3.6 \text{ V}$	1.5	3.4	5.8	1.5	6.0	ns
t_{dis}	disable time	$\overline{\text{nOE}}$ to nY						
		$V_{CC} = 1.2 \text{ V}$	--	25	--	--	--	ns
		$V_{CC} = 1.65 \text{ V to } 1.95 \text{ V}$	2.0	7.2	15.5	2.0	15.7	ns
		$V_{CC} = 2.3 \text{ V to } 2.7 \text{ V}$	1.6	5.7	8.6	1.6	8.8	ns
		$V_{CC} = 3.0 \text{ V to } 3.6 \text{ V}$	1.3	4.5	6.5	1.3	7.0	ns
C_{PD}	power dissipation capacitance	per buffer ; $V_I = \text{GND to } V_{CC}$						
		$V_{CC} = 1.65 \text{ V to } 1.95 \text{ V}$	--	12	--	--	--	pF
		$V_{CC} = 2.3 \text{ V to } 2.7 \text{ V}$	--	13	--	--	--	pF
		$V_{CC} = 3.0 \text{ V to } 3.6 \text{ V}$	--	14	--	--	--	pF
$t_{sk(o)}$	output skew time	$V_{CC} = 3.0 \text{ V to } 3.6 \text{ V}$	--	--	1.0	--	1.5	ns

Note:

Typical values are measured at $T_{amb} = 25 \text{ °C}$ and $V_{CC} = 1.65 \text{ V}, 1.8 \text{ V}, 2.5 \text{ V}, 3.3 \text{ V}$ and 3.6 V respectively.

t_{pd} is the same as t_{PLH} and t_{PHL} .

Skew between any two outputs of the same package switching in the same direction. This parameter is guaranteed by design.

C_{PD} is used to determine the dynamic power dissipation (P_D in μW).

$$P_D = C_{PD} \times V_{CC}^2 \times f_i \times N + \sum(C_L \times V_{CC}^2 \times f_o) \text{ where:}$$

f_i = input frequency in MHz;

f_o = output frequency in MHz;

C_L = output load capacitance in

pF; V_{CC} = supply voltage in V;

N = number of inputs switching;

$\sum(C_L \times V_{CC}^2 \times f_o)$ = sum of outputs.

Waveforms and test circuit

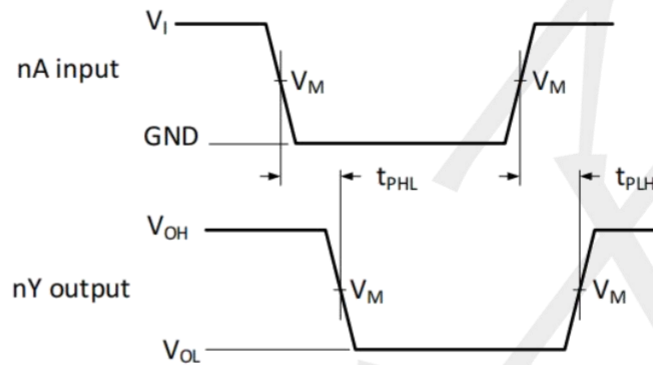

Measurement points are given in Table 8.

V_{OL} and V_{OH} are typical output voltage levels that occur with the output load.

Fig. 5. The input nA to output nY propagation delays

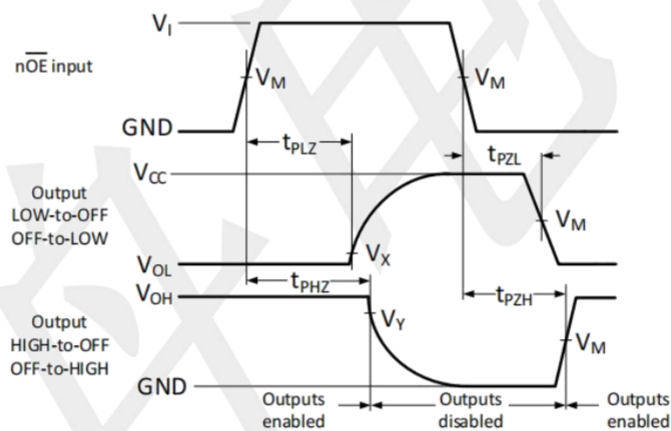

Measurement points are given in Table 8.

V_{OL} and V_{OH} are typical output voltage levels that occur with the output load.

Fig. 6. 3-state enable and disable times

Measurement points

Supply voltage	Input	Output		
V_{CC}	V_M	V_M	V_X	V_Y
1.65 V to 1.95 V	$0.5V_{CC}$	$0.5V_{CC}$	$V_{OL} + 0.15V$	$V_{OH} - 0.15V$
2.3 V to 2.7 V	$0.5V_{CC}$	$0.5V_{CC}$	$V_{OL} + 0.15V$	$V_{OH} - 0.15V$
3.0 V to 3.6 V	1.5 V	1.5 V	$V_{OL} + 0.3V$	$V_{OH} - 0.3V$

SN74LVC125APWR-TP

Quad Bus Buffer with 3-State Control Inputs

WWW.TECHPUBLIC.COM

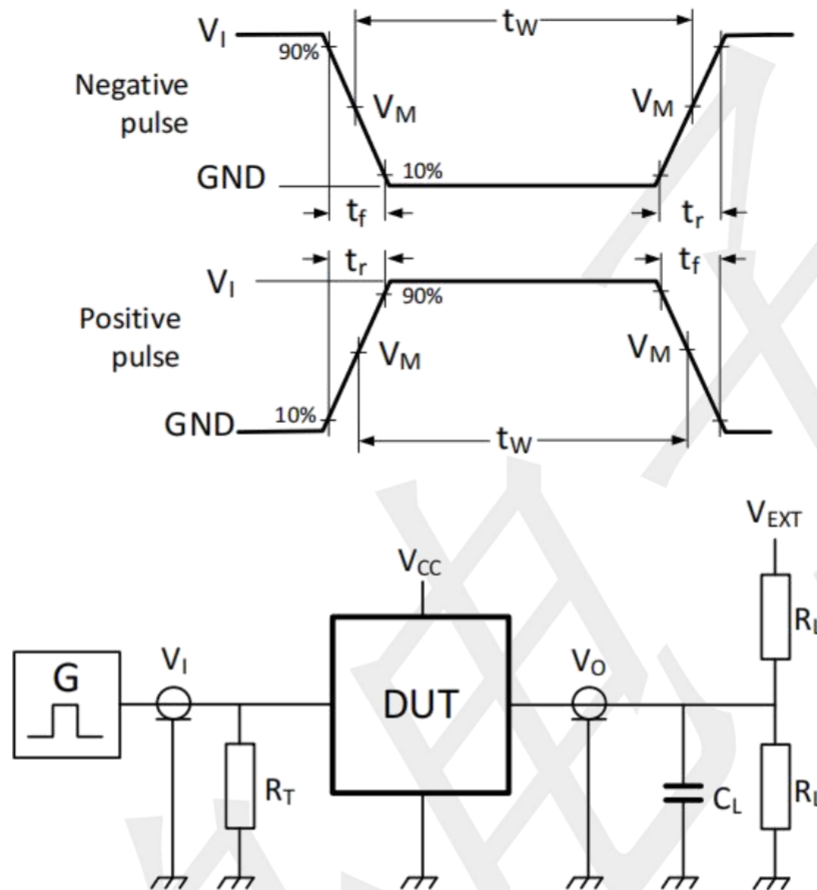

Test data is given in Table 9.

Definitions for test circuit:

R_L = Load resistance.

C_L = Load capacitance including jig and probe capacitance.

R_T = Termination resistance should be equal to the output impedance Z_o of the pulse generator.

V_{EXT} = External voltage for measuring switching times.

Fig. 7. Test circuit for measuring switching times

Test data

Supply voltage	Input		Load		V_{EXT}		
	V_I	$t_r = t_f$	C_L	R_L	t_{PLH}, t_{PHL}	t_{PZH}, t_{PHZ}	t_{PZL}, t_{PLZ}
1.65 V to 1.95 V	V_{CC}	≤ 2.0 ns	15 pF	500 Ω	open	GND	$2 \times V_{CC}$
2.3 V to 2.7 V	V_{CC}	≤ 2.0 ns	15 pF	500 Ω	open	GND	$2 \times V_{CC}$
3.0 V to 3.6 V	3 V	≤ 2.0 ns	15 pF	500 Ω	open	GND	6V

SN74LVC125APWR-TP

Quad Bus Buffer with 3-State Control Inputs

WWW.TECHPUBLIC.COM

Package information TSSOP-14

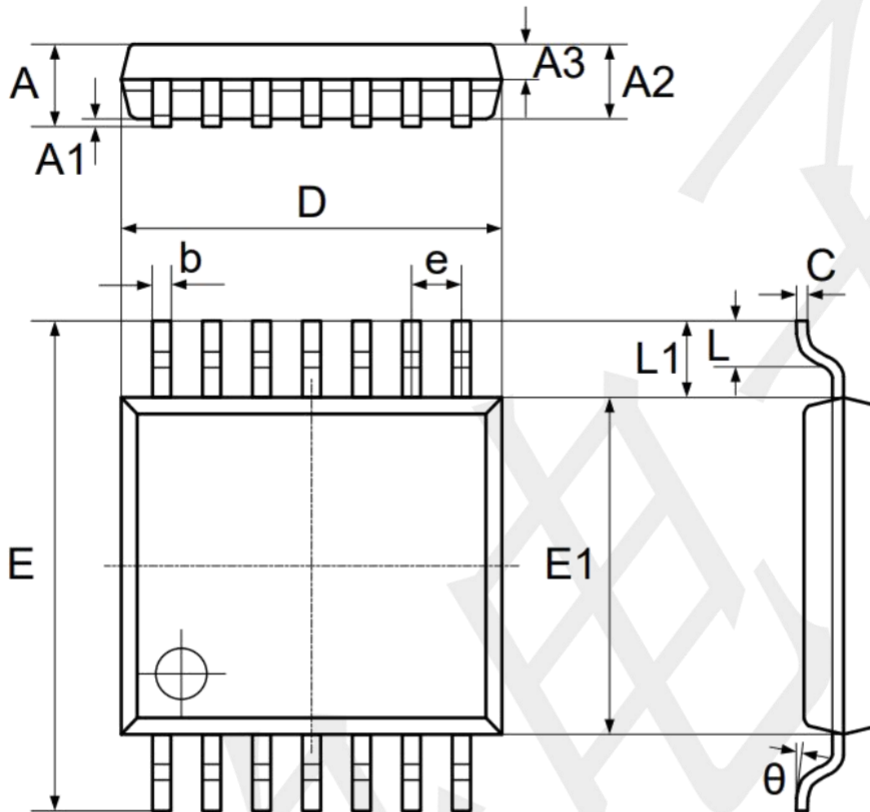

Symbol	Dimensions In Millimeters		Dimensions In Inches	
	Min	Max	Min	Max
A	-	1.200	-	0.047
A1	0.050	0.150	0.002	0.006
A2	0.900	1.050	0.035	0.041
A3	0.390	0.490	0.015	0.019
b	0.200	0.290	0.008	0.011
C	0.130	0.180	0.005	0.007
D	4.860	5.060	0.191	0.199
E	6.200	6.600	0.244	0.260
E1	4.300	4.500	0.169	0.177
e	0.650 TYP.		0.026 TYP.	
L1	1.000 REF.		0.039 REF.	
L	0.450	0.750	0.018	0.030
θ	0°	8°	0°	8°