



钲地半导体
Tudi Semiconductor

Tudi Semiconductor

Product Specification

TUDI-ICL7660

CMOS Voltage Converters

网址 www.sztdbdt.com Q

用芯智造 · 卓越品质

**semiconductor device
manufacturer**

- Design
- research and development
- production
- and sales



Features

- Simple Conversion of +5V Logic Supply to $\pm 5V$ Supplies
- Simple Voltage Multiplication ($V_{OUT} = (-) nV_{IN}$)
- Typical Open Circuit Voltage Conversion Efficiency 99.9%
- Typical Power Efficiency 98%
- Wide Operating Voltage Range
 - ICL7660-1.5V to 10.0V
 - ICL7660-1.5V to 12.0V
- ICL7660A 100% Tested at 3V
- Easy to Use - Requires Only 2 External Non-Critical Passive Components
- No External Diode Over Full Temp. and Voltage Range
- Pb-Free Plus Anneal Available (RoHS Compliant)

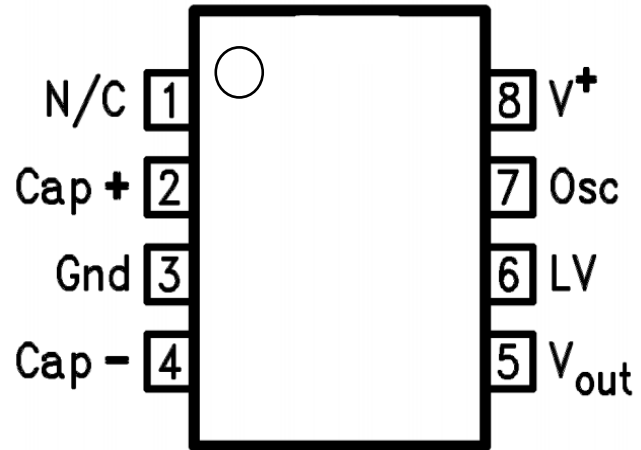

Pin Diagram

Description

The ICL7660 and ICL7660A are monolithic CMOS power supply circuits which offer unique performance advantages over previously available devices. The ICL7660 performs supply voltage conversions from positive to negative for an input range of +1.5V to +10.0V resulting in complementary output voltages of -1.5V to -10.0V and the ICL7660A does the same conversions with an input range of +1.5V to +12.0V resulting in complementary output voltages of -1.5V to -12.0V. Only 2 noncritical external capacitors are needed for the charge pump and charge reservoir functions.

The ICL7660 and ICL7660A can also be connected to function as voltage doublers and will generate output voltages up to +18.6V with a +10V input. Contained on the chip are a series DC supply regulator, RC oscillator, voltage level translator, and four output power MOS switches. A unique logic element senses the most negative voltage in the device and ensures that the output N-Channel switch source-substrate junctions are not forward biased. This assures latchup free operation. The oscillator, when unloaded, oscillates at a nominal frequency of 10kHz for an input supply voltage of 5.0V. This frequency can be lowered by the addition of an external capacitor to the "OSC" terminal, or the oscillator may be overdriven by an external clock. The "LV" terminal may be tied to GROUND to bypass the internal series regulator and improve low voltage (LV) operation. At medium to high voltages (+3.5V to +10.0V for the ICL7660 and +3.5V to +12.0V for the ICL7660A), the LV pin is left floating to prevent device latchup.

Applications

- On Board Negative Supply for Dynamic RAMs
- Localized μ Processor (8080 Type) Negative Supplies
- Inexpensive Negative Supplies
- Data Acquisition Systems



Pin Description

Name	Pin#	Function
NC	1	
CAP+	2	"+" Capacitor Plate
GND	3	Ground
CAP-	4	"-" Capacitor Plate
VOUT	5	Output Voltage
LV	6	Low Supply Voltage
OSC	7	Oscillator
V+	8	Supply Voltage

Electrical Characteristics

(V+ = 5V, TA = 25°C, COSC = 0, unless otherwise specified)

PARAMETER	SYMBOL	TEST CONDITIONS	MIN	TYP	MAX	UNITS
Supply Current	I+	RL=∞	-	170	500	μA
Supply Voltage Range-Lo	VL+	MIN≤TA≤MAX,RL=10kΩ, LV to GND	1.5	-	3.5	V
Supply Voltage Range-Hi	VL+	MIN≤TA≤MAX,RL=10kΩ, LV to Open	3.0	-	10	V
Output Source Resistans	RoUT	IouT=20mA,TA=25°C	-	55	100	Ω
		IouT=20mA,0°C≤TA≤70°C	-	-	120	
		V+=2V,IOUT=3mA, LV to GND,0°C≤TA≤70°C	-	-	300	
Oscillator Frequency	fosc		8	-	18	kHz
Power Efficiency	PEF	RL=5kΩ	95	98	-	%
Voltage Conversion Efficiency	VoUTEF	RL=∞	97	99.9	-	%
Oscillator Impedance	Zosc	V+=2V	-	1.0	-	MΩ
		V+=5V	-	100	-	kΩ



Absolute Maximum Ratings

Condition	Min	Max
Supply Voltage	-	+12V
LV and OSC Input Voltage	-0.3V to(V++0.3V)for V+<5.5V	
	(V+-5.5V)to(V++0.3V)for V+>5.5V	
Current into LV	20μA for V+>3.5V	
Temperature Range	0°C	85°C
Thermal Resistance,θJA(°C/W)	-	150
Maximum Storage Temperature Range	-65°C	150°C
Lead Temperature (Soldering,10 seconds)		260°C

Note: Absolute Maximum Ratings indicate limits beyond which damage to the device may occur. Operating Ratings indicate conditions for which the device is intended to be functional, but specific performance is not ensured.

Typical Application Circuits

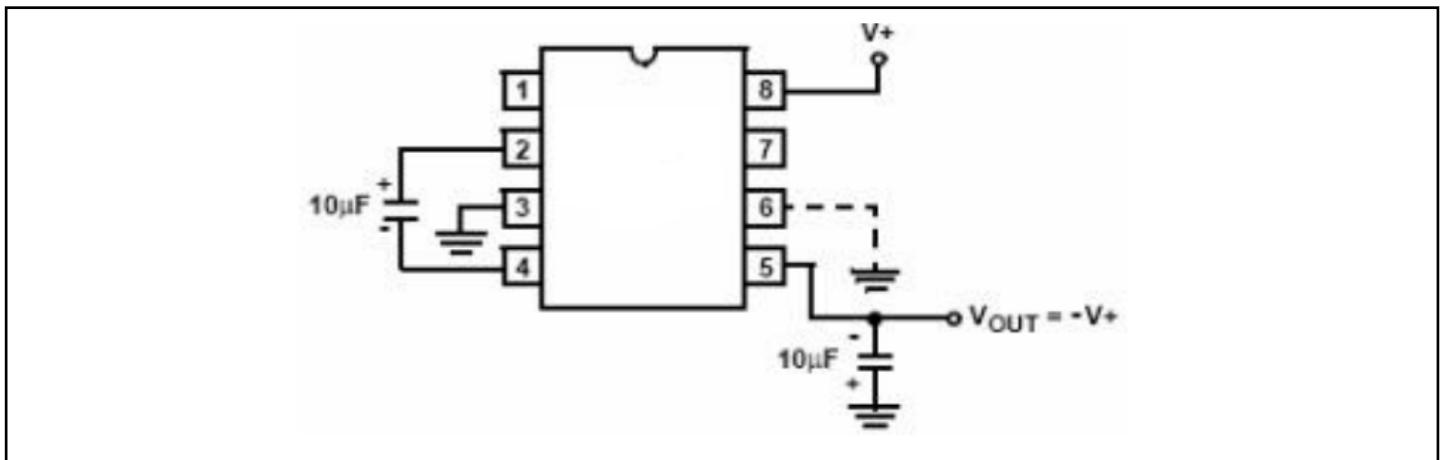

FIGURE 1. SIMPLE NEGATIVE CONVERTER

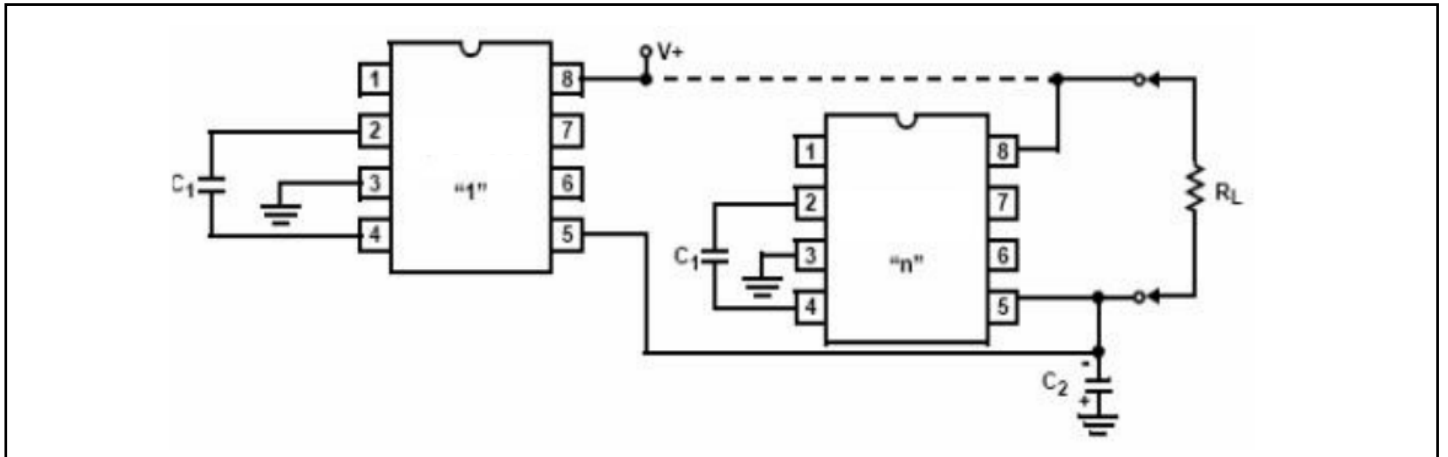

FIGURE 2. PARALLELING DEVICES

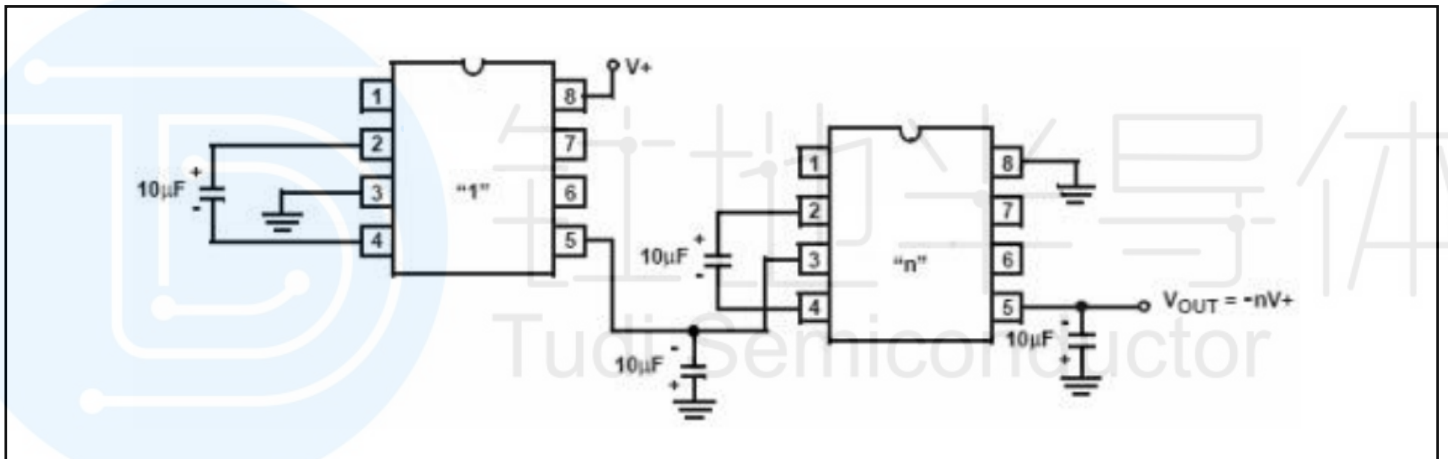

FIGURE 3. CASCADING DEVICES FOR INCREASED OUTPUT VOLTAGE

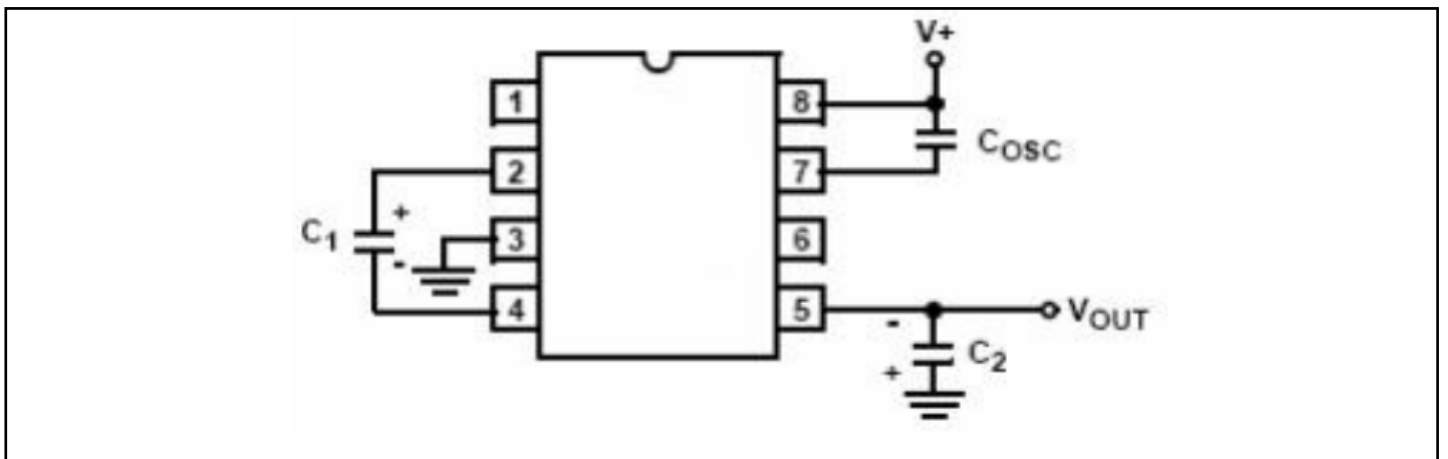

FIGURE 4. LOWERING OSCILLATOR FREQUENCY

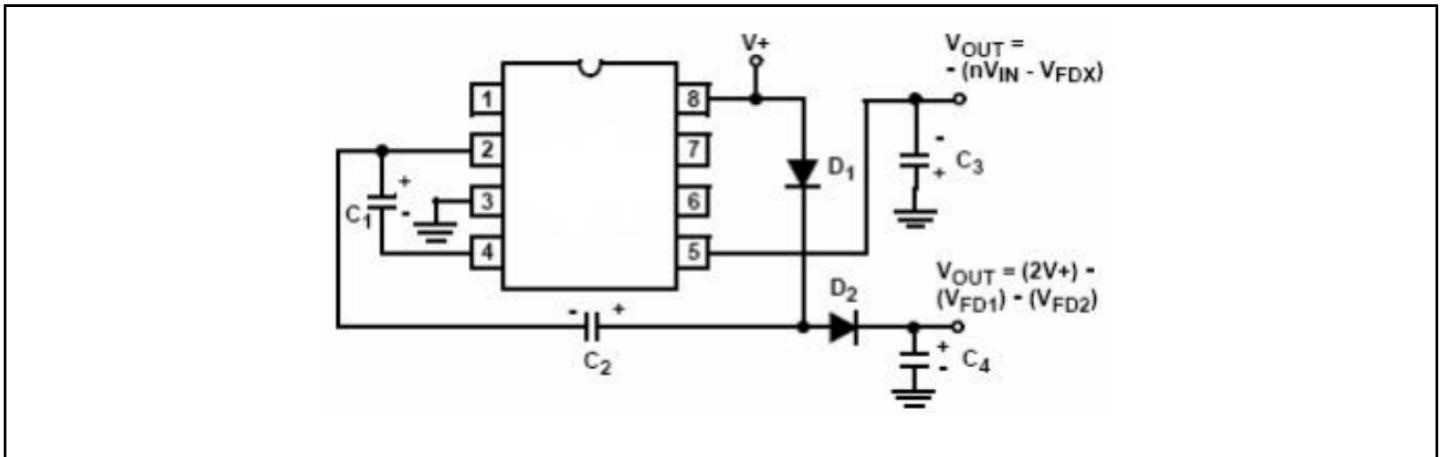

FIGURE 5. COMBINED NEGATIVE VOLTAGE CONVERTER AND POSITIVE DOUBLER

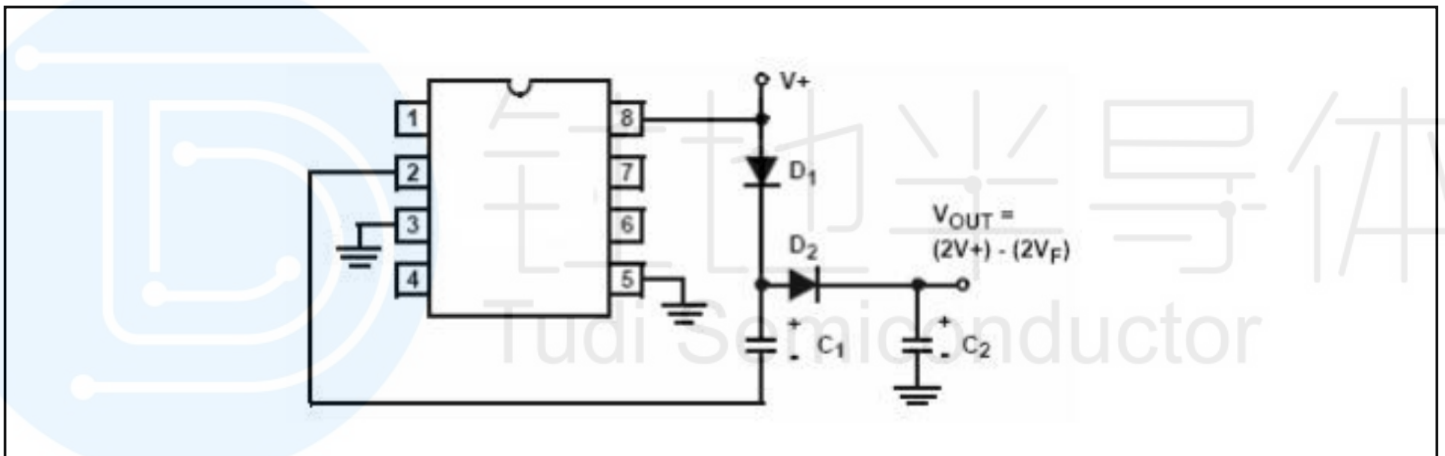

FIGURE 6. POSITIVE VOLT DOUBLER

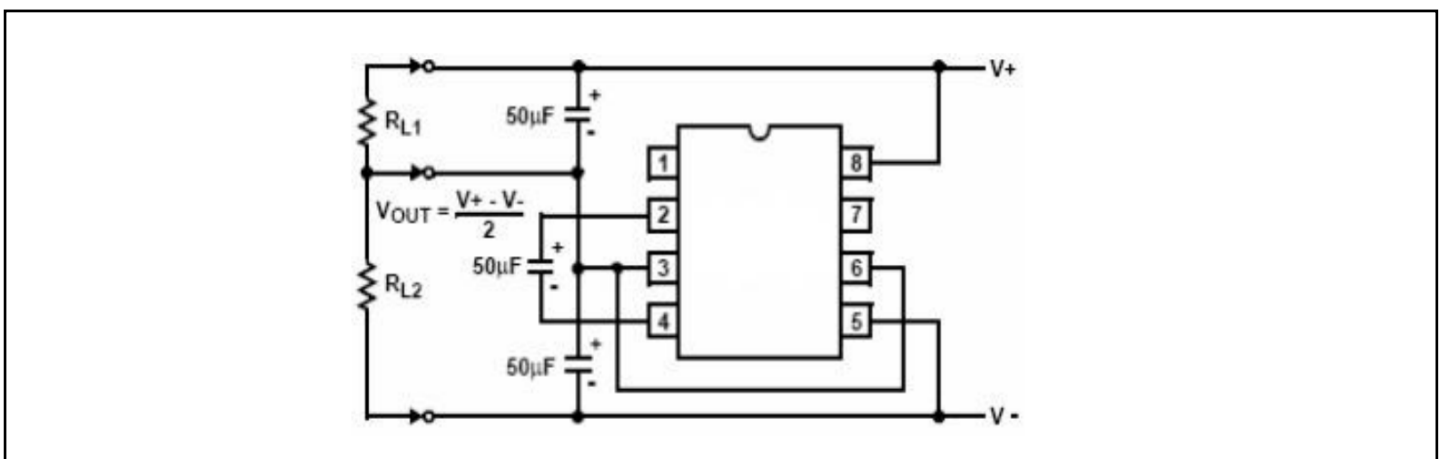
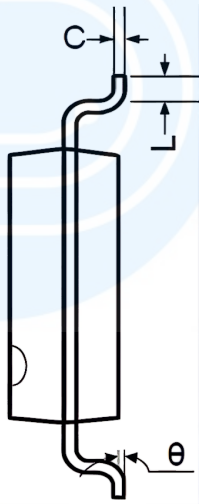
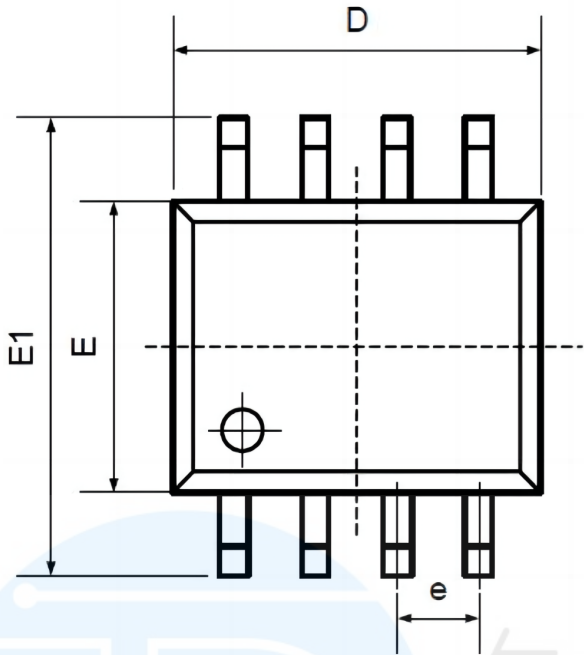

FIGURE 7. SPLITTING A SUPPLY IN HALF



Package SOP8



Symbol	Dimensions In Millimeters		Dimensions In Inches	
	Min	Max	Min	Max
A	1.350	1.750	0.053	0.069
A1	0.100	0.250	0.004	0.010
A2	1.350	1.550	0.053	0.061
B	0.330	0.510	0.013	0.020
C	0.190	0.250	0.007	0.010
D	4.780	5.000	0.188	0.197
E	3.800	4.000	0.150	0.157
E1	5.800	6.300	0.228	0.248
e	1.270TYP		0.050TYP	
L	0.400	1.270	0.016	0.050
theta	0°	8°	0°	8°

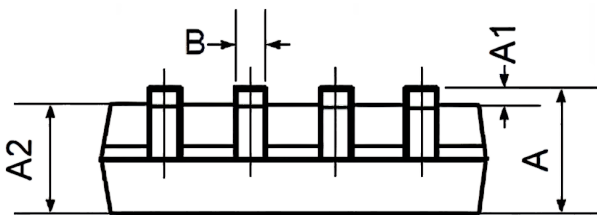



Package DIP8

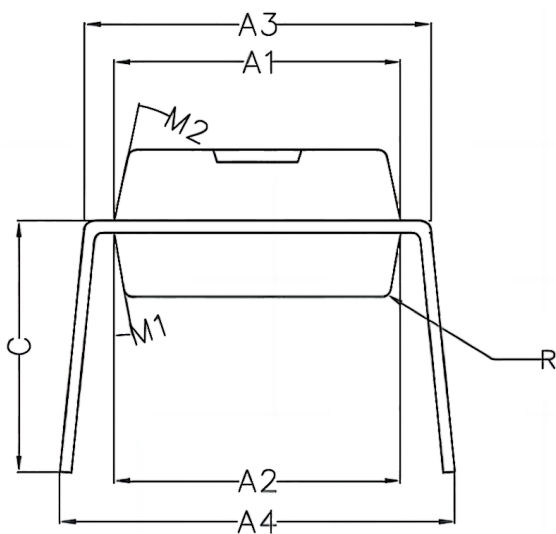
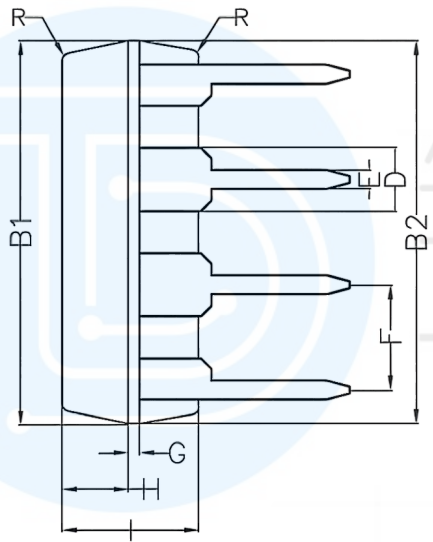
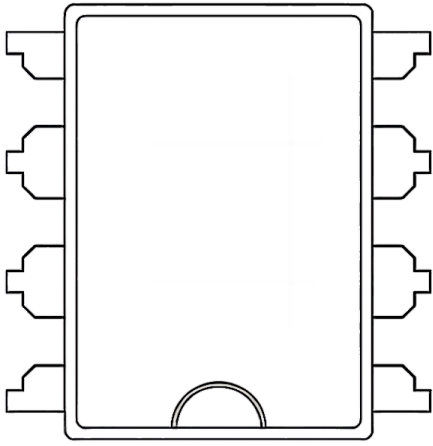

Symbol	Min	Non	Max
A1	6.28	6.33	6.38
A2	6.33	6.38	6.43
A3	7.52	7.62	7.72
A4	7.80	8.40	9.00
B1	9.15	9.20	9.25
B2	9.20	9.25	9.30
C		5.57	
D		1.52	
E	0.43	0.45	0.47
F		2.54	
G		0.25	
H	1.54	1.59	1.64
I	3.22	3.27	3.32
R		0.20	
M1	9°	10°	11°
M2	11°	12°	13°



Order information

Order Number	Package	Package Quantity	Marking On The park	Temperature	Operating Voltage
ICL7660CBAZA-T-TUDI	SOP8	Tape,Reel,2500	7660CBAZ	0°C to 70°C	1.5V to 10V
ICL7660CPAZ-TUDI	DIP8	Tube,50,A box of 2000	7660CPAZ		
ICL7660ACBAZA-T-TUDI	SOP8	Tape,Reel,2500	7660ACBAZ		
ICL7660ACPAZ-TUDI	DIP8	Tube,50,A box of 2000	7660ACPAZ		
ICL7660AIBAZA-T-TUDI	SOP8	Tape,Reel,2500	7660AIBAZ	0°C to 85°C	1.5V to 12V
ICL7660AIPAZ-TUDI	DIP8	Tube,50,A box of 2000	7660AIPAZ		



钰地半导体
Tudi Semiconductor



Important statement:

- TUDI Semiconductor reserves the right to modify the product manual without prior notice! Before placing an order, customers need to confirm whether the obtained information is the latest version and verify the completeness of the relevant information.
- Any semi-guide product is subject to failure or malfunction under specified conditions. It is the buyer's responsibility to comply with safety standards when using TUDI Semiconductor products for system design and whole machine manufacturing. And take the appropriate safety measures to avoid the potential in the risk of loss of personal injury or loss of property situation!
- TUDI Semiconductor products have not been licensed for life support, military, and aerospace applications, and therefore TUDI Semiconductor is not responsible for any consequences arising from the use of this product in these areas.
- If any or all TUDI Semiconductor products (including technical data, services) described or contained in this document are subject to any applicable local export control laws and regulations, they may not be exported without an export license from the relevant authorities in accordance with such laws.
- The specifications of any and all TUDI Semiconductor products described or contained in this document specify the performance, characteristics, and functionality of said products in their standalone state, but do not guarantee the performance, characteristics, and functionality of said products installed in Customer's products or equipment. In order to verify symptoms and conditions that cannot be evaluated in a standalone device, the Customer should ultimately evaluate and test the device installed in the Customer's product device.
- TUDI Semiconductor documentation is only allowed to be copied without any alteration of the content and with the relevant authorization. TUDI Semiconductor assumes no responsibility or liability for altered documents.
- TUDI Semiconductor is committed to becoming the preferred semiconductor brand for customers, and TUDI Semiconductor will strive to provide customers with better performance and better quality products.