



钰地半导体  
Tudi Semiconductor

## Product Specification

TUDI-AD8606

10MHz, Rail-to-Rail Input/Output Low Power Operational Amplifiers

网址 [www.sztdbdt.com](http://www.sztdbdt.com) 🔍

**用芯智造 · 卓越品质**

**semiconductor device  
manufacturer**

- Design
- research and development
- production
- and sales



## Features

- Low Quiescent Current: 650  $\mu$  A
- Gain Bandwidth Product: 10MHz
- Operates on 1.8V ~ 5.5V Supplies
- Slew Rate: 7.5V/  $\mu$  s
- Rail-to-Rail Input and Output (RRIO)
- Unity Gain Stable
- No Phase Reversal
- Extended Temperature Ranges From -40 ° C to +125 ° C

## Applications

- Battery or Solar Powered Systems
- Portable Equipment
- Sensor Conditioning
- Analog Active Filters
- Medical Equipment
- Audio Output
- White Goods
- Smoke/Gas/Environment Sensors

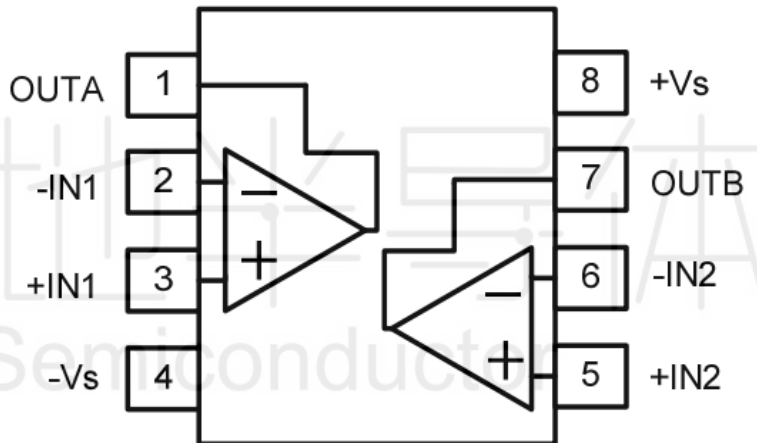
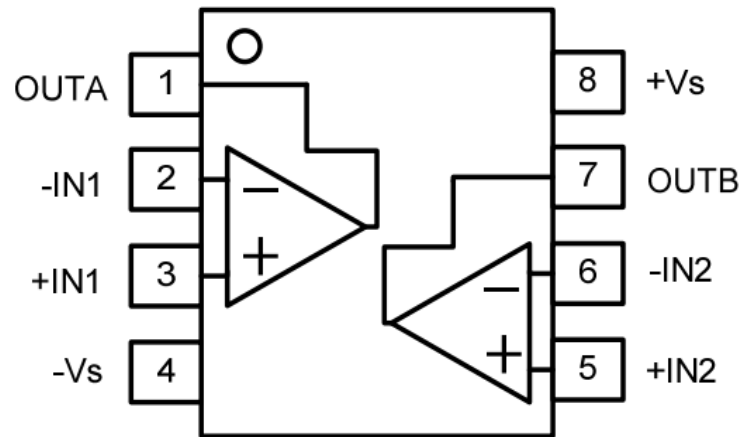

SOP8/DIP8/MSOP8/TSSOP8

## Description

The AD8606(dual) is low power, rail-to-rail input and output amplifiers operated on 1.8 to 5.5 supplies. Despite their low quiescent current.

The AD8606 provides excellent overall performance and versatility. They have both rail-to-rail input and output range. The output voltage swing extends to within 10mV of each rail, providing the maximum output dynamic range with excellent overdrive recovery.

AD8606 is unity gain stable and has a gain bandwidth product of 10MHz (typical).

They provide high CMRR and PRSS performance and can operate from a single supply voltage as low as 1.8V.

These features make the AD8606 well suited for single-supply, battery-powered applications.

They can be used as plus-in replacements for many commercially available op-amps to reduce power and improve input/output range and performance.



## Pin Functions

Name	Description	Note
+Vs	Positive power supply	A bypass capacitor of 0.1 $\mu$ F as close to the part as possible should be placed between power supply pins or between supply pins and ground.
-Vs	Negative power supply or ground	If it is not connected to ground, bypass it with a capacitor of 0.1 $\mu$ F as close to the part as possible
-IN	Negative input	Inverting input of the amplifier. Voltage range of this pin can go from -Vs-0.3V to +Vs-1V.
+IN	Positive input	Non-inverting input of the amplifier. This pin has the same voltage range as -IN.
OUT	Output	The output voltage range extends to within millivolts of each supply rail.
NC	No connection	

## Product Specification

### Recommended Operating Conditions

Parameter	Rating	Unit
DC Supply Voltage	1.8V-5.5V	V
Input common-mode voltage range	-Vs ~ +Vs	V
Operating ambient temperature	-40 to 125	$^{\circ}$ C

### Thermal Data

Parameter	Rating	Unit
Package Thermal Resistance	206(MSOP8) 155(SOP8) 125(DIP8) 105(TSSOP8)	$^{\circ}$ C/W



### Electrical Characteristics

(+Vs=+5V,-Vs=0,VeM=Vs/2,TA=+25°C,RL=10kΩto Vs/2,unless otherwise noted)

Parameter	Symbol	Conditions	Min	Typ	Max	Unit
<b>Out Characteristics</b>						
Output Voltage Swing from Rail		RL=100kΩ		1		mV
		RL=10kΩ		8		mV
		RL=2kΩ		40		mV
Short-Circuit Current	IoUT	Sourcing		21		mA
		Sinking		22		mA
<b>Input Characteristics</b>						
Input Offset Voltage	Vos			±0.6	±5	mV
Input Offset Voltage Drift	ΔVos/ΔT	-40 to 125°C		±2.0		μV°C
Input Bias Current	IB			±2.5		pA
Input Offset Current	Ios			±2.5		pA
Common-Mode Voltage Range	VcM	Vs =5.5V	-0.1		5.6	V
Common-Mode Rejection Ratio	CMRR	VcM=0.1V to 4.9V		125		dB
Open-Loop Voltage Gain	AOL	Vo=0.2V to 4.8V		120		dB
<b>Dynamic Performance</b>						
Gain Bandwidth Product	GBWP	G=+1		10		MHz
Slew Rate	SR	G=+1,2V Output Step		7.5		V/μs
<b>Noise Performance</b>						
Voltage Noise Density	en	f=1kHz		12		nV/√Hz
<b>Power Supply</b>						
Operating Voltage Range			1.8		5.5	V
Power Supply Rejection Ratio	PSRR	VS = 2.1V-5.5V	80	100		dB
Quiescent Current /Amplifier	Io			650		μA



### Absolute Maximum Ratings

Parameter	Rating	Units
Power Supply:+Vs to-Vs	6.0	V
Input Voltage	-Vs -0.5V to+Vs+0.5V	V
Input Current(2)	10	mA
Storage Temperature Range	-65 to 150	°C
Junction Temperature	150	°C
Operating Temperature Range	-40 to 125	°C
ESD Susceptibility,HBM	2000	V

(1) Stresses exceeding the absolute maximum ratings may damage the device. The device may not function or be operable above the recommended operating conditions and stressing the parts to these levels is not recommended. In addition, extended exposure to stresses above the recommended operating conditions may affect device reliability. The absolute maximum ratings are stress ratings only.

(2) Input terminals are diode-clamped to the power-supply rails. Input signals that can swing more than 0.5V beyond the supply rails should be current-limited to 10mA or less.

## Application Notes

### Driving Capacitive Loads

Driving large capacitive loads can cause stability problems for voltage feedback op amps. As the load capacitance increases, the feedback loop's phase margin decreases, and the closed loop bandwidth is reduced. This produces gain peaking in the frequency response, with overshoot and ringing in the step response. A unity gain buffer ( $G = +1$ ) is the most sensitive to capacitive loads, but all gains show the same general behavior.

When driving large capacitive loads with these op amps (e.g.,  $> 100$  pF when  $G = +1$ ), a small series resistor at the output ( $R_{iso}$  in Figure 1) improves the feedback loop's phase margin (stability) by making the output load resistive at higher frequencies. It does not, however, improve the bandwidth. To select  $R_{iso}$ , check the frequency response peaking (or step response overshoot) on the bench. If the response is reasonable, you do not need  $R_{iso}$ . Otherwise, start  $R_{iso}$  at 1k and modify its value until the response is reasonable.

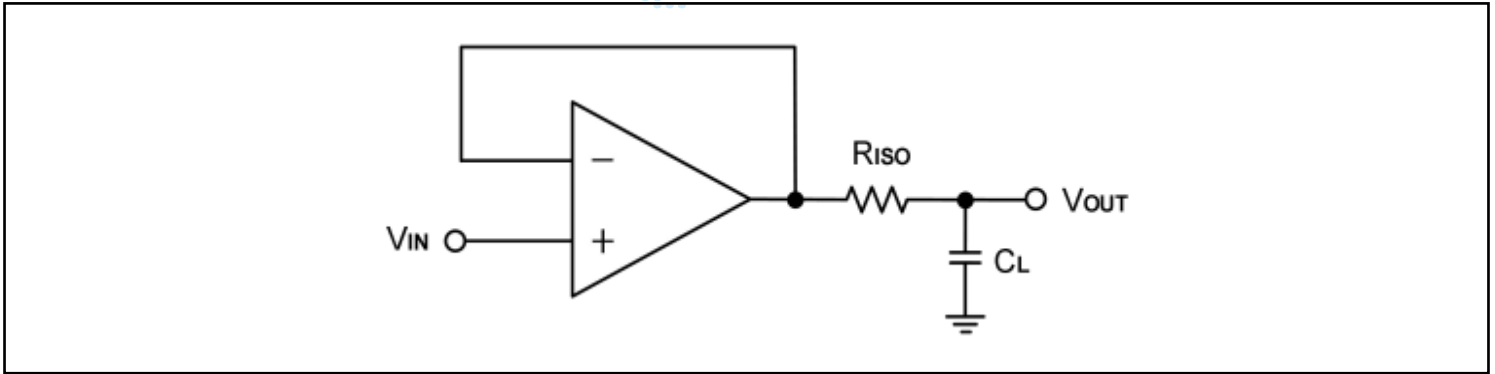

Figure 1. Indirectly Driving Heavy Capacitive Load

An improvement circuit is shown in Figure 2. It provides DC accuracy as well as AC stability.  $R_F$  provides the DC accuracy by connecting the inverting signal with the output,  $C_F$  and  $R_{iso}$  serve to counteract the loss of phase margin by feeding the high frequency component of the output signal back to the amplifier's inverting input, thereby preserving phase margin in the overall feedback loop.

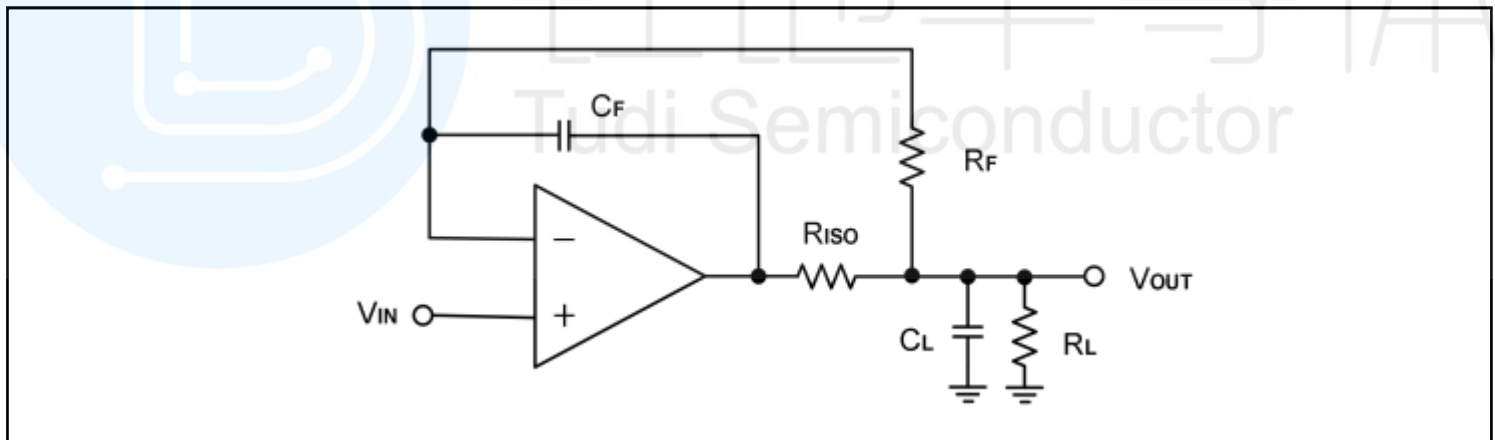

Figure 2. Indirectly Driving Heavy Capacitive Load with DC Accuracy

For non-inverting configuration, there are two other ways to increase the phase margin:  
(a) by increasing the amplifier's gain or  
(b) by placing a capacitor in parallel with the feedback resistor to counteract the parasitic capacitance associated with inverting node, as shown in Figure 3.

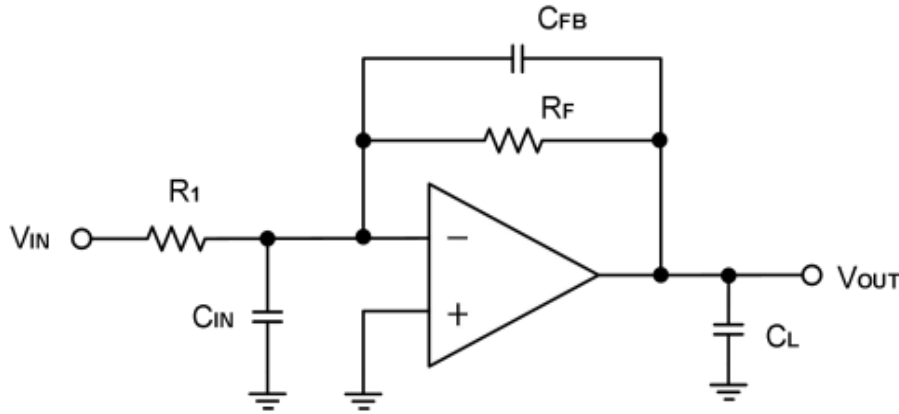

Figure 3. Adding a Feedback Capacitor in the Non-inverting Configuration

### Power-Supply Bypassing and Layout

The AD8606 operates from a single +1.8V to +5.5V supply or dual  $\pm 1.05\text{V}$  to  $\pm 2.75\text{V}$  supplies. For single-supply operation, bypass the power supply +Vs with a  $0.1\mu\text{F}$  ceramic capacitor which should be placed close to the +Vs pin. For dual-supply operation, both the +Vs and the -Vs supplies should be bypassed to ground with separate  $0.1\mu\text{F}$  ceramic capacitors.  $2.2\mu\text{F}$  tantalum capacitor can be added for better performance.

The length of the current path is directly proportional to the magnitude of parasitic inductances and thus the high frequency impedance of the path. High speed currents in an inductive ground return create an unwanted voltage noise. Broad ground plane areas will reduce the parasitic inductance. Thus a ground plane layer is important for high speed circuit design.

### Typical Application Circuits

#### Differential Amplifier

The circuit shown in Figure 4 performs the differential function. If the resistors ratios are equal ( $R_4/R_3 = R_2/R_1$ ), then  $V_{OUT} = (V_{IP} - V_{IN}) \times R_2/R_1 + V_{REF}$ .

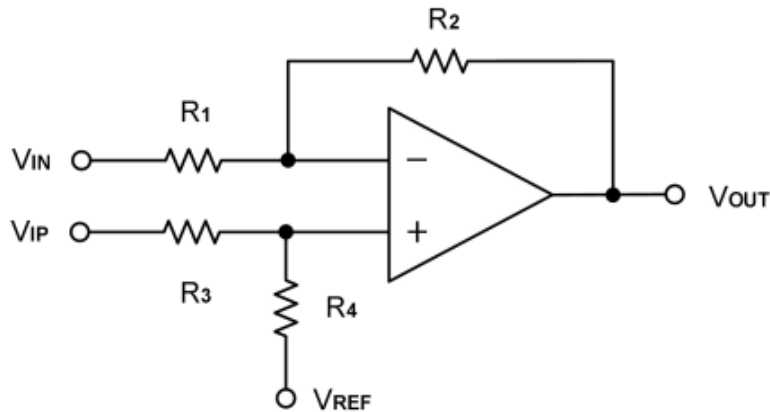

Figure 4. Differential Amplifier

### Low Pass Active Filter

When receiving low-level signals, limiting the bandwidth of the incoming signals into the system is often required. The simplest way to establish this limited bandwidth is to place an RC filter at the noninverting terminal of the amplifier. If even more attenuation is needed, a multiple pole filter is required. The Sallen-Key filter can be used for this task, as Figure 5. For best results, the amplifier should have a bandwidth that is 8 to 10 times the filter frequency bandwidth. Failure to follow this guideline can result in reduction of phase margin. The large values of feedback resistors can couple with parasitic capacitance and cause undesired effects such as ringing or oscillation in high-speed amplifiers. Keep resistors value as low as possible and consistent with output loading consideration.

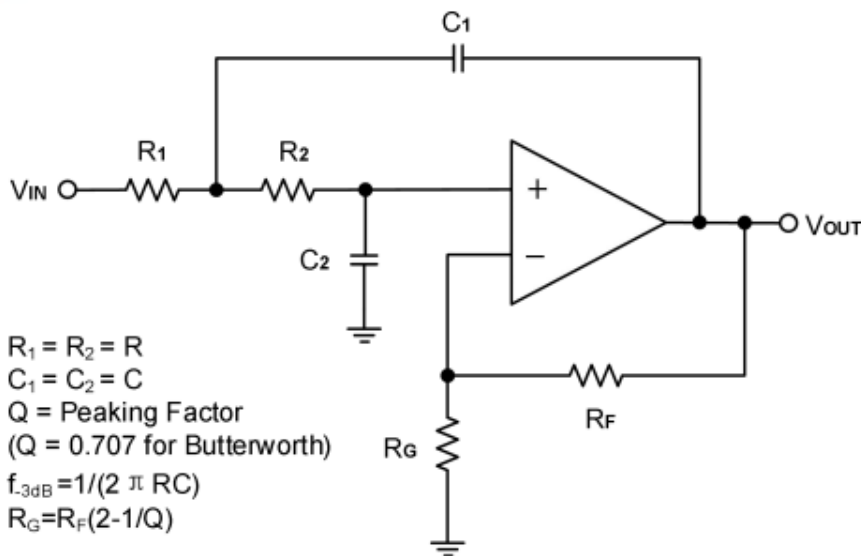
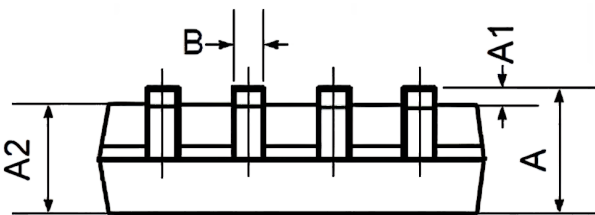
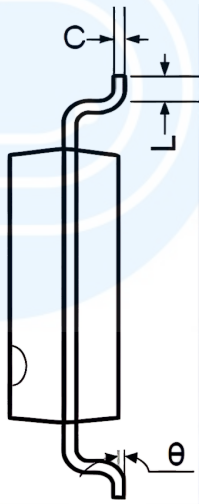
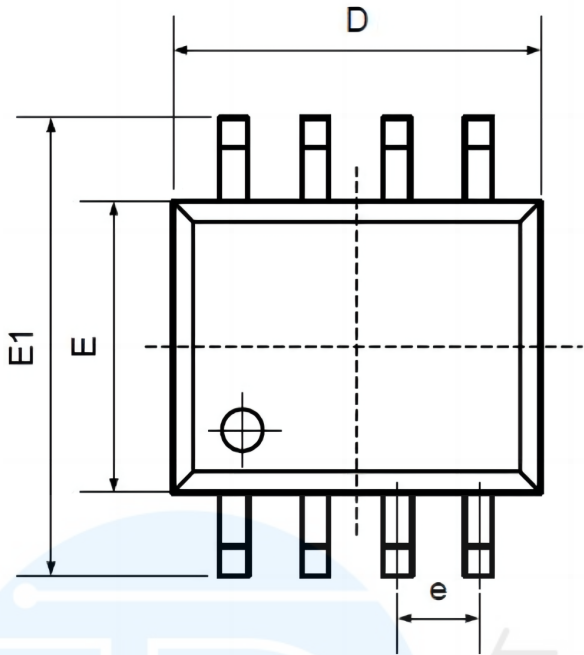

Figure 5. Two-Pole Low-Pass Sallen-Key Active Filter



Package SOP8



Symbol	Dimensions In Millimeters		Dimensions In Inches	
	Min	Max	Min	Max
A	1.350	1.750	0.053	0.069
A1	0.100	0.250	0.004	0.010
A2	1.350	1.550	0.053	0.061
B	0.330	0.510	0.013	0.020
C	0.190	0.250	0.007	0.010
D	4.780	5.000	0.188	0.197
E	3.800	4.000	0.150	0.157
E1	5.800	6.300	0.228	0.248
e	1.270TYP		0.050TYP	
L	0.400	1.270	0.016	0.050
θ	0°	8°	0°	8°



Package MSOP8

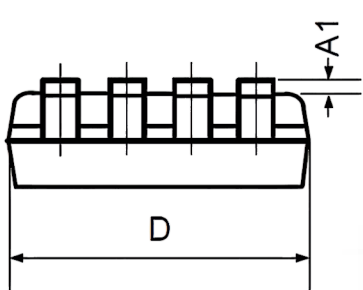
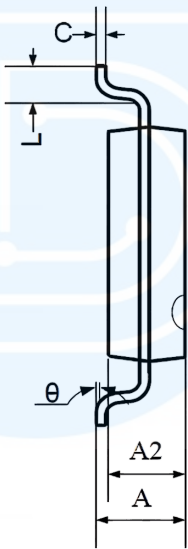
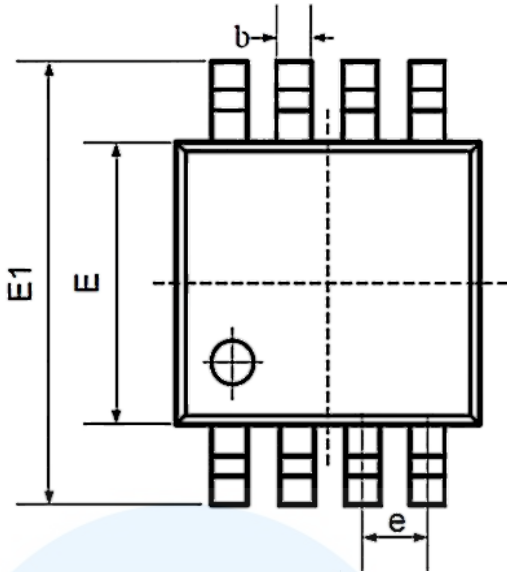

Symbol	Dimensions In Millimeters		Dimensions In Inches	
	Min	Max	Min	Max
A	0.800	1.200	0.031	0.047
A1	0.000	0.200	0.000	0.008
A2	0.760	0.970	0.030	0.038
b	0.30 TYP		0.012 TYP	
C	0.15 TYP		0.006 TYP	
D	2.900	3.100	0.114	0.122
e	0.65 TYP		0.026 TYP	
E	2.900	3.100	0.114	0.122
E1	4.700	5.100	0.185	0.201
L	0.410	0.650	0.016	0.026
θ	0°	6°	0°	6°



Package DIP8

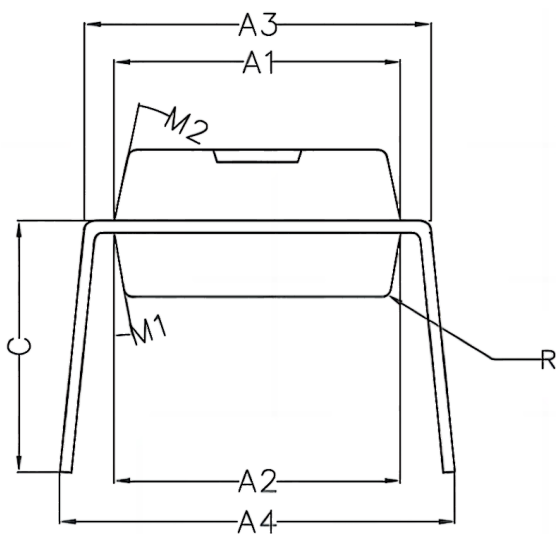
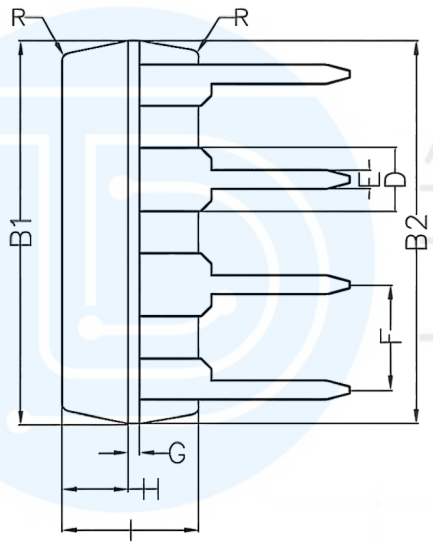
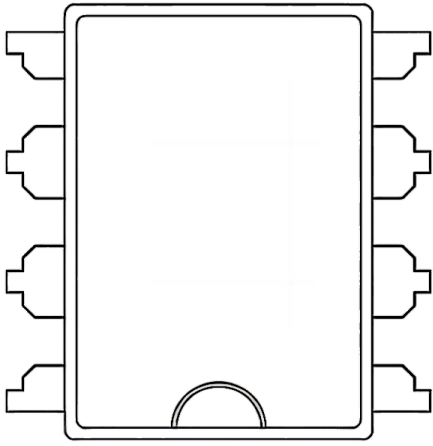

Symbol	Min	Non	Max
A1	6.28	6.33	6.38
A2	6.33	6.38	6.43
A3	7.52	7.62	7.72
A4	7.80	8.40	9.00
B1	9.15	9.20	9.25
B2	9.20	9.25	9.30
C		5.57	
D		1.52	
E	0.43	0.45	0.47
F		2.54	
G		0.25	
H	1.54	1.59	1.64
I	3.22	3.27	3.32
R		0.20	
M1	9°	10°	11°
M2	11°	12°	13°



Package TSSOP8

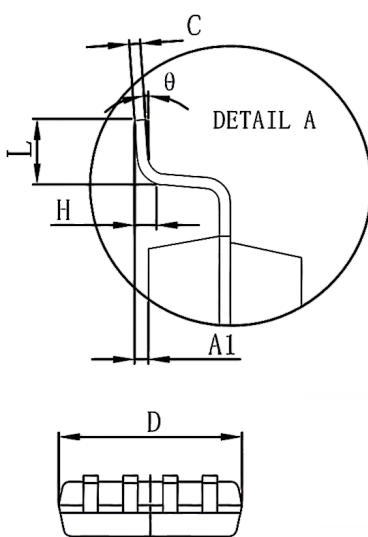
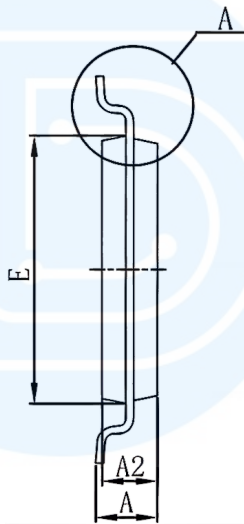
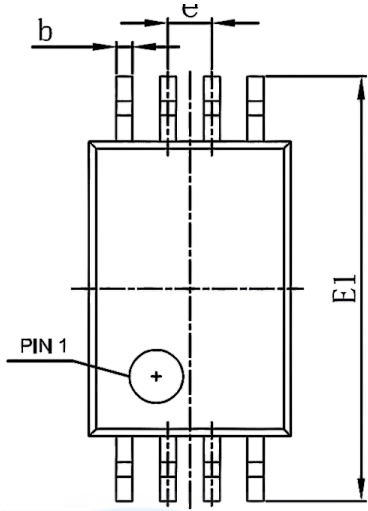

Symbol	Dimensions In Millimeters		Dimensions In Inches	
	Min	Max	Min	Max
D	2.900	3.100	0.114	0.122
E	4.300	4.500	0.169	0.177
b	0.190	0.300	0.007	0.012
C	0.090	0.200	0.004	0.008
E1	6.250	6.550	0.246	0.258
A		1.200		0.047
A2	0.800	1.000	0.031	0.039
A1	0.050	0.150	0.002	0.006
e	0.65(BSC)		0.026(BSC)	
L	0.500	0.700	0.020	0.028
H	0.25(TYP)		0.01(TYP)	
$\theta$	1°		1°	



## Order information

Order Number	Package	Package Quantity	Marking On The park	Temperature
AD8606ARZ-REEL-TUDI	SOP8	Tape,Reel,2500	AD8606A	- 40°C to 125°C
AD8606ARMZ-REEL-TUDI	MSOP8	Tape,Reel,2500	B6A	
AD8606ARUZ-REEL-TUDI	TSSOP8	Tape,Reel,2500	AD8606A	
AD8606ANZ-TUDI	DIP8	Tube,50,A box of 2000	AD8606AN	



钰地半导体  
Tudi Semiconductor



## Important statement:

- TUDI Semiconductor reserves the right to modify the product manual without prior notice! Before placing an order, customers need to confirm whether the obtained information is the latest version and verify the completeness of the relevant information.
- Any semi-guide product is subject to failure or malfunction under specified conditions. It is the buyer's responsibility to comply with safety standards when using TUDI Semiconductor products for system design and whole machine manufacturing. And take the appropriate safety measures to avoid the potential in the risk of loss of personal injury or loss of property situation!
- TUDI Semiconductor products have not been licensed for life support, military, and aerospace applications, and therefore TUDI Semiconductor is not responsible for any consequences arising from the use of this product in these areas.
- If any or all TUDI Semiconductor products (including technical data, services) described or contained in this document are subject to any applicable local export control laws and regulations, they may not be exported without an export license from the relevant authorities in accordance with such laws.
- The specifications of any and all TUDI Semiconductor products described or contained in this document specify the performance, characteristics, and functionality of said products in their standalone state, but do not guarantee the performance, characteristics, and functionality of said products installed in Customer's products or equipment. In order to verify symptoms and conditions that cannot be evaluated in a standalone device, the Customer should ultimately evaluate and test the device installed in the Customer's product device.
- TUDI Semiconductor documentation is only allowed to be copied without any alteration of the content and with the relevant authorization. TUDI Semiconductor assumes no responsibility or liability for altered documents.
- TUDI Semiconductor is committed to becoming the preferred semiconductor brand for customers, and TUDI Semiconductor will strive to provide customers with better performance and better quality products.