

Product Overview

NCA8541 is an octal buffer/driver used for improving driver ability of bus-oriented receivers and transmitters, clock drivers etc. and ensuring the accuracy of signal timing. It provides eight channels with two output-enable(/OE) input that low active. When both /OE1 and /OE2 are active, NCA8541 transmits data from A to Y. When either output-enable is high, the outputs are in the high-impedance state. During power up and power down, /OE should be tied to VCC through a pull-up resistor to ensure the high impedance state.

NCA8541 can tolerate up to 5.5V input voltage and each channel supports maximum 24mA current drive. All unused inputs must be held at V_{CC} or GND to prevent excess supply current.

Key Features

- Qualified for Automotive Grade 1 applications:
NCA8541-Q1TSTR
- Inputs are TTL compatible
- Power supply voltage: 4.5V to 5.5V
- 5.5V Tolerant Inputs
- ESD Protection Exceeds JESD 22
 - 4000V Human-Body Model
 - 2000V Charged-Device Model
- Operation temperature: -40°C ~125°C
- RoHS & REACH compliant packages: TSSOP20

Applications

- Motor driver
- Traction inverter
- I/O modules
- LED displays

Device Information

Part Number	Package	Body Size
NCA8541-DTSTR	TSSOP20	6.50mm × 4.50mm
NCA8541-Q1TSTR	TSSOP20	6.50mm × 4.50mm

Functional Block Diagrams

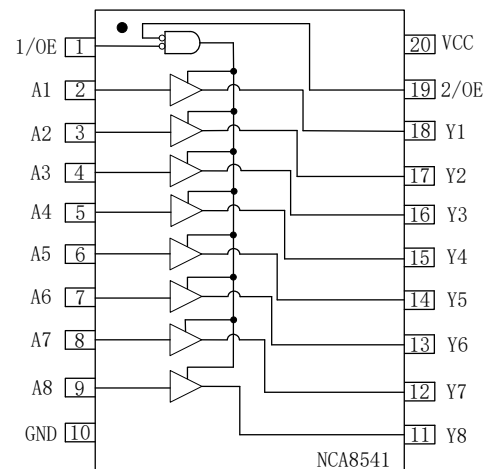

Figure 1. NCA8541 Block Diagram

INDEX

1. PIN CONFIGURATION AND FUNCTIONS	3
2. ABSOLUTE MAXIMUM RATINGS	4
3. ESD RATINGS	4
4. RECOMMENDED OPERATING CONDITIONS	4
5. THERMAL INFORMATION	5
6. SPECIFICATIONS	5
6.1. ELECTRICAL CHARACTERISTICS	5
6.2. DYNAMIC CHARACTERISTICS	6
6.3. PARAMETER MEASUREMENT INFORMATION	6
7. FUNCTION DESCRIPTION	6
7.1. OVERVIEW	6
8. APPLICATION NOTE	7
8.1. APPLICATION INFORMATION	7
8.2. TYPICAL APPLICATION CIRCUIT	7
9. PACKAGE INFORMATION	8
10. ORDERING INFORMATION	9
11. TAPE AND REEL INFORMATION	10
12. REVISION HISTORY	11

1. Pin Configuration and Functions

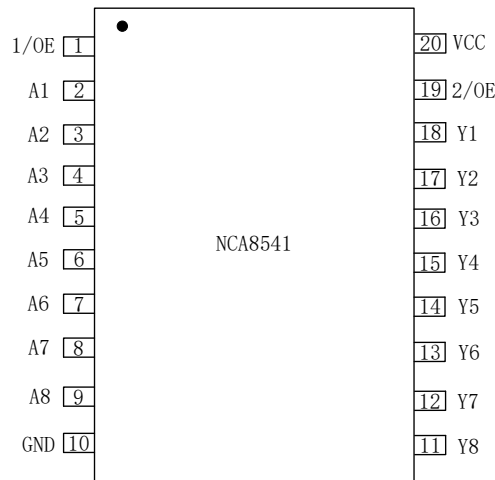

Figure 1.1 NCA8541 Package

Table 1.1 NCA8541 Pin Configuration and Description

NCA8541 PIN NO.	SYMBOL	FUNCTION
1	1/OE	Active low Output-enable 1
2	A1	Input of Y1
3	A2	Input of Y2
4	A3	Input of Y3
5	A4	Input of Y4
6	A5	Input of Y5
7	A6	Input of Y6
8	A7	Input of Y7
9	A8	Input of Y8
10	GND	Ground
11	Y8	Output of A8
12	Y7	Output of A7
13	Y6	Output of A6
14	Y5	Output of A5
15	Y4	Output of A4
16	Y3	Output of A3
17	Y2	Output of A2

18	Y1	Output of A1
19	2/OE	Active low Output-enable 2
20	V _{CC}	Power

2. Absolute Maximum Ratings

Parameters	Symbol	Min	Typ	Max	Unit	Comments
Power Supply Voltage	V _{CC}	-0.5		7	V	
Maximum Input Voltage	V _I	-0.5		V _{CC} +0.5	V	The maximum voltage must not exceed 7V
Maximum Output Voltage	V _O	-0.5		V _{CC} +0.5	V	The maximum voltage must not exceed 7V
Input clamp current	I _{IK}	-20		20	mA	V _I < 0 or V _I > V _{CC}
Output clamp current	I _{OK}	-20		20	mA	V _I < 0 or V _I > V _{CC}
Continuous output current	I _O	-35		35	mA	V _O =0 to V _{CC}
Ambient Temperature	T _a	-40		125	°C	
Junction Temperature	T _J			150	°C	
Storage Temperature	T _{stg}	-65		150	°C	

3. ESD Ratings

Parameters	Ratings	Value	Unit
Electrostatic discharge	Human body model (HBM), per AEC-Q100-002-RevD	±4.0	kV
	Charged device model (CDM), per AEC-Q100-011-RevB	±2.0	kV

4. Recommended Operating Conditions

Over recommended operating free-air temperature range (unless otherwise noted)

Parameters	Symbol	Min	Typ	Max	Unit	Comments
Power Supply Voltage	V _{CC}	4.5		5.5	V	
High-level output current	I _{OH}	-24			mA	
Low-level output current	I _{OL}			24	mA	
Input transition rise or fall rate	Δt/Δv			500	ns/V	
Operating free-air temperature	T _a	-40		125	°C	

(1) All unused inputs of the device must be held at V_{CC} or GND to ensure proper device operation.

5. Thermal Information

Parameters	Symbol	TSSOP20	Unit
Junction-to-ambient thermal resistance	$R_{\theta JA}$	103	$^{\circ}C/W$
Junction-to-case(top) thermal resistance	$R_{\theta JC (top)}$	37.7	$^{\circ}C/W$
Junction-to-board thermal resistance	$R_{\theta JB}$	54	$^{\circ}C/W$
Junction-to- top characterization parameter	Ψ_{JT}	6.8	$^{\circ}C/W$
Junction-to- board characterization parameter	Ψ_{JB}	65.1	$^{\circ}C/W$

6. Specifications

6.1. Electrical Characteristics

$T_a = -40^{\circ}C$ to $125^{\circ}C$. Unless otherwise noted, Typical values are at $T_a = 25^{\circ}C$

Parameters	Symbol	Min	Typ	Max	Unit	Comments
Supply current	I_{CC}			80	μA	$V_{CC}=5.5V$, $V_I = V_{CC}$ or GND, $I_O = 0$
Increasing supply current ⁽¹⁾	ΔI_{CC}			3	mA	One input at 0.5V or 2.4V, Other inputs at GND or V_{CC} , $V_{CC}=5.5V$
High-level input voltage	V_{IH}	2			V	
Low-level input voltage	V_{IL}			0.8	V	
High-level output voltage	V_{OH}	4.4	4.49		V	$V_{CC}=4.5V$, $I_{OH}=-20\mu A$
		3.9	4.3		V	$V_{CC}=4.5V$, $I_{OH}=-6mA$
		3.9				$V_{CC}=4.5V$, $I_{OH}=-24mA$
Low-level output voltage	V_{OL}		0.001	0.1	V	$V_{CC}=4.5V$, $I_{OL}=20\mu A$
			0.17	0.5	V	$V_{CC}=4.5V$, $I_{OL}=6mA$
				0.55	V	$V_{CC}=4.5V$, $I_{OL}=24mA$
Three-state output current	I_{OZ}	-2.5		2.5	μA	$V_{CC}=5.5V$, $V_O=0$ to V_{CC} , $V_I = V_{IH}$ or V_{IL}
Input current	I_I	-1		1	μA	$V_{CC}=5.5V$, $V_I = V_{CC}$ or GND
Input capacitance	C_i		4		pF	
Output capacitance	C_o		8.5		pF	

(1) The increase in supply current for each input that is at one of the specified TTL voltage levels, rather than 0V or V_{CC} .

6.2. Dynamic Characteristics

$V_{CC}=4.5V\sim 5.5V$, $T_a=-40^{\circ}C$ to $125^{\circ}C$. Unless otherwise noted, Typical values are at $T_a = 25^{\circ}C$, see [figure1](#).

Parameters	Symbol	Min	Typ	Max	Unit	Comments
Propagation Delay	t_{PLH}		8	15	ns	$V_{CC}=4.5V$
	t_{PHL}		7	15		$V_{CC}=5.5V$
Enable to Data Valid	t_{PZH}		7	15	ns	$V_{CC}=4.5V$
	t_{PZL}		7	15		$V_{CC}=5.5V$
Disable to tri-state	t_{PHZ}		8	15	ns	$V_{CC}=4.5V$
	t_{PLZ}		7.5	15		$V_{CC}=5.5V$

6.3. Parameter measurement information

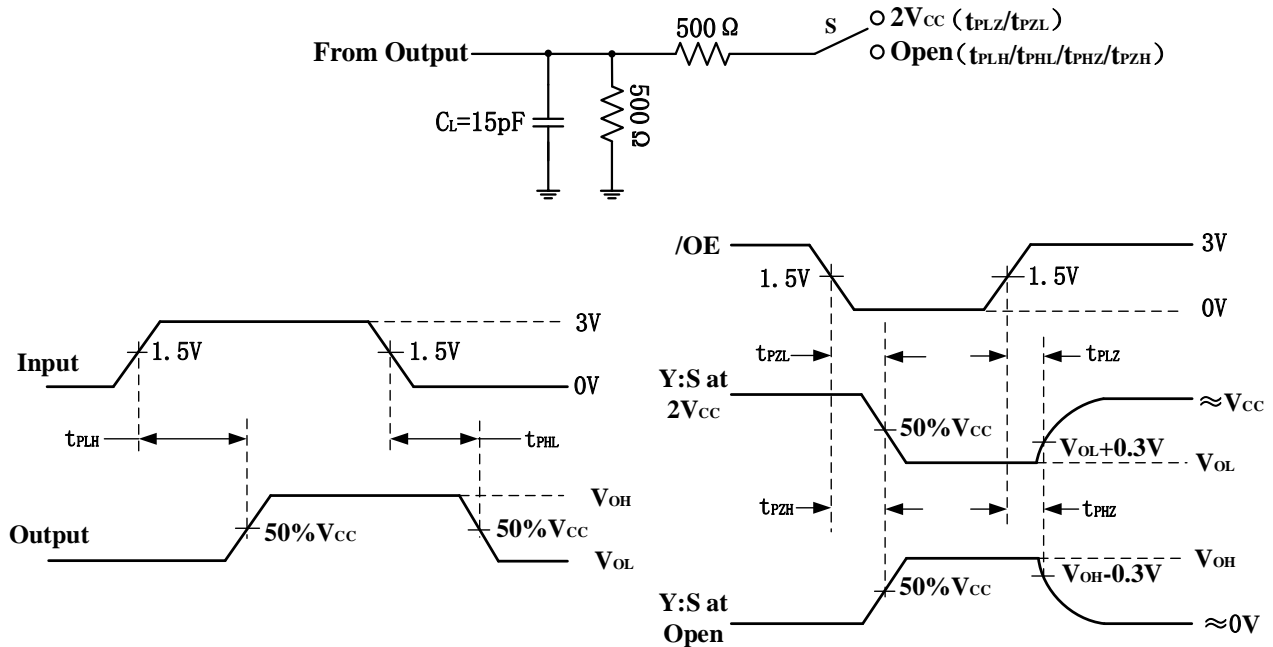

Note:

- 1) All input pulses with the following characteristics: $PRR \leq 1MHz$, $ZO = 50\Omega$, $tr \leq 2.5ns$, $tf \leq 2.5ns$;
- 2) C_i includes probe and test-fixture capacitance.

Figure 6.1 Load Circuit and Voltage Waveforms for NCA8541

7. Function Description

7.1. Overview

NCA8541 is an octal buffer used for improving driver ability of 3-state memory address, clock drivers, and bus-oriented receivers and transmitters and ensuring the accuracy of signal timing. It provides eight channels with two output-enable(/OE) input that low active. When both 1/OE and 2/OE are active, NCA8541 transmits data from A to Y. When either output-enable is high, the outputs are in the high-impedance state. During power up and power down, /OE should be tied to V_{CC} through a pull-up resistor to ensure the high impedance state. All unused inputs of NCA8541 must be held at V_{CC} or GND to prevent excess I_{CC} .

Table 7.1 Function Table

A_IN ⁽¹⁾	1/OE status	2/OE status	VCC status	Y_OUT	Comment
L	L	L	Ready	L	Normal operation.
H	L	L	Ready	H	
X	H	X	Ready	Z	Output Disabled, the output is high impedance.
X	X	H	Ready	Z	
X	X	X	Unready	Z	The output follows the same status with the input after V _{CC} is powered on and output is enabled.

(1) L=Logic low; H=Logic high; X=Logic low or logic high.

8. Application Note

8.1. Application Information

The NCA8541 can be used in motor driver, traction inverter, IO modules and LED displays. The maximum output current can be up to 24 mA.

8.2. Typical Application Circuit

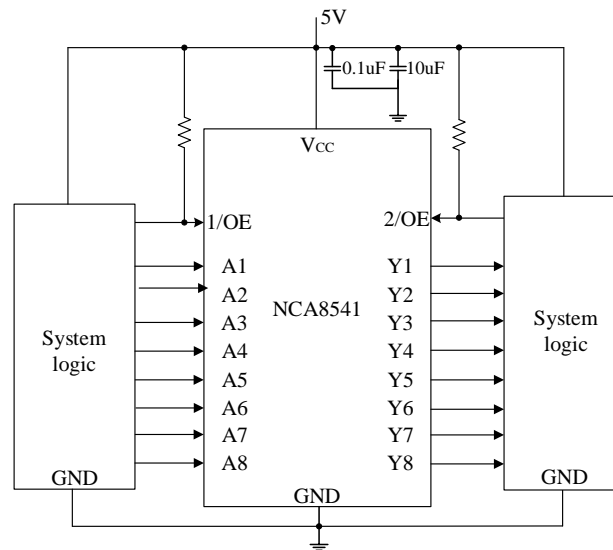

Figure 8.1 Typical application circuit for NCA8541

9. Package Information

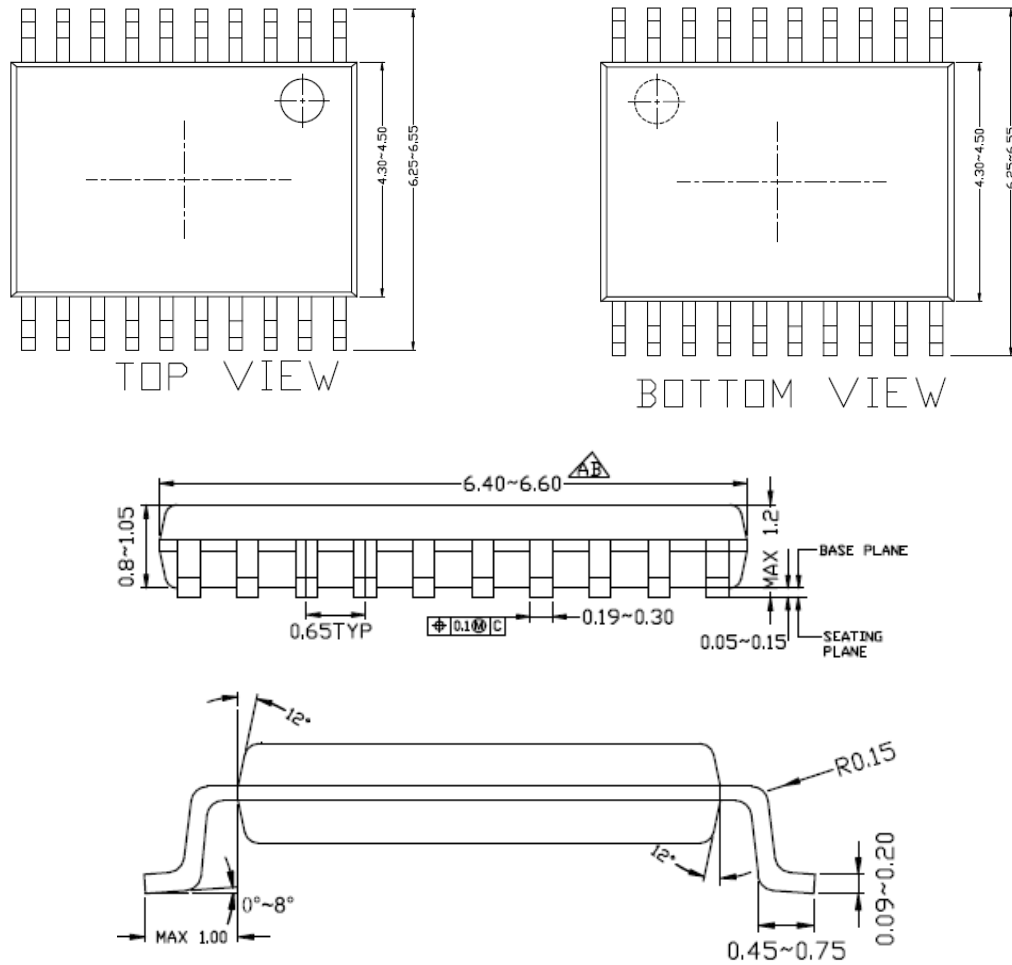
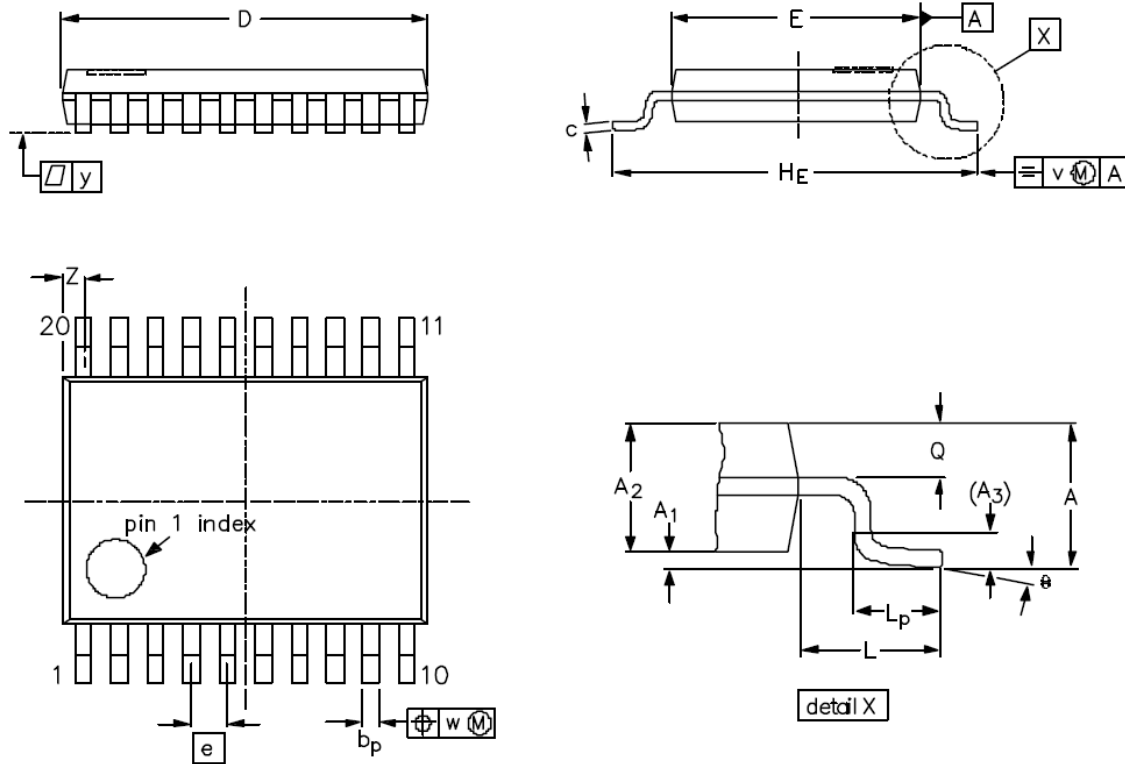

Figure 9.1 TSSOP20 Package Shape and Dimension in millimeters for NCA8541-DTSTR



DIMENSIONS (mm are the original dimensions)

UNIT	A _{max.}	A ₁	A ₂	A ₃	b _p	c	D ⁽¹⁾	E ⁽²⁾	e	HE	L	L _p	Q	v	w	y	Z ⁽¹⁾	θ
mm	1.10	0.15 0.05	0.96 0.80	0.25	0.30 0.19	0.2 0.1	6.6 6.4	4.5 4.3	0.65	6.6 6.2	1.0	0.75 0.50	0.4 0.3	0.2	0.13	0.1	0.5 0.2	8° 0°

Figure 9.2 TSSOP20 Package Shape and Dimension in millimeters for NCA8541-Q1TSTR

10. Ordering Information

Part Number	PINS	Temperature	MSL	Package Type	Package Drawing	SPQ
NCA8541-DTSTR	20	-40 to 125°C	1	TSSOP20	TSSOP20	2500
NCA8541-Q1TSTR	20	-40 to 125°C	1	TSSOP20	TSSOP20	2500

NOTE: All packages are RoHS-compliant with peak reflow temperatures of 260 °C according to the JEDEC industry standard classifications and peak solder temperatures.

11. Tape and Reel Information

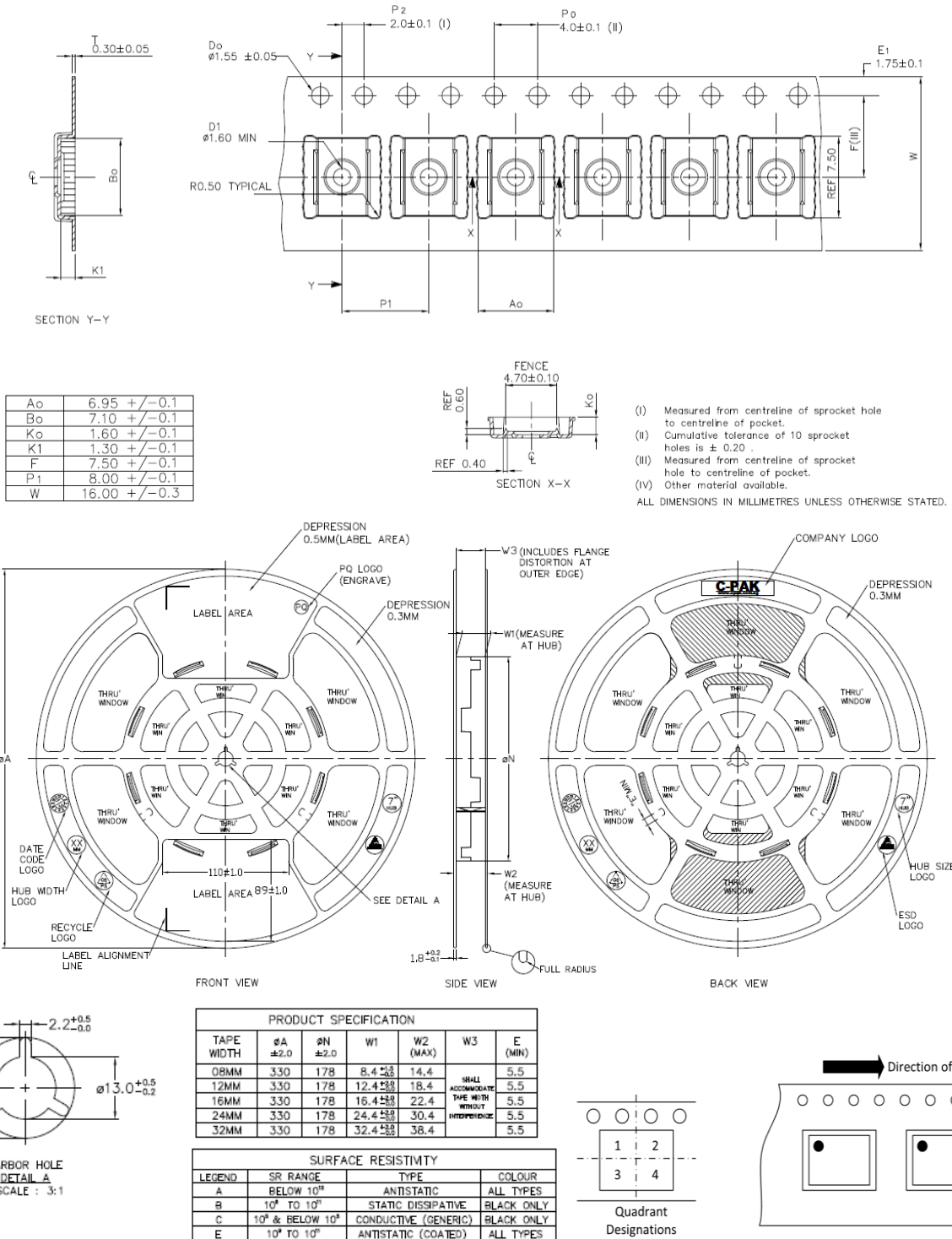

Figure 11.1 Tape and Reel Information of TSSOP

12. Revision History

Revision	Description	Date
1.0	Initial Version.	2023/4/23
1.1	Add the POD information for NCA8541-DTSTR	2023/11/7

IMPORTANT NOTICE

The information given in this document shall in no event be regarded as any warranty or authorization of, express or implied, including but not limited to accuracy, completeness, merchantability, fitness for a particular purpose or infringement of any third party's intellectual property rights.

You are solely responsible for your use of Novosense' products and applications, and for the safety thereof. You shall comply with all laws, regulations and requirements related to Novosense's products and applications, although information or support related to any application may still be provided by Novosense.

The resources are intended only for skilled developers designing with Novosense' products. Novosense reserves the rights to make corrections, modifications, enhancements, improvements or other changes to the products and services provided. Novosense authorizes you to use these resources exclusively for the development of relevant applications designed to integrate Novosense's products. Using these resources for any other purpose, or any unauthorized reproduction or display of these resources is strictly prohibited. Novosense shall not be liable for any claims, damages, costs, losses or liabilities arising out of the use of these resources.

For further information on applications, products and technologies, please contact Novosense (www.novosns.com).

Suzhou Novosense Microelectronics Co., Ltd