



Descriptions

The FUSB340TMX is a high-speed bidirectional passive switch in mux or demux configurations suited for USB Type-C™ application supporting USB 3.1 Gen 1 and Gen 2 datarates. Based on control pin SEL, the device provides switching on diferential channels between Port L0 or Port L1 to Port C0.

The FUSB340TMX is ageneric analog differential passive switch that can work for any high-speed interface applications requiring a common mode voltage range of 0 to 2V and differential signaling with differential amplitude up to 1.8Vpp. It employs adaptive tracking that ensures the channel remains unchanged for the entire common mode voltage range.

Excellent dynamic characteristics of the device allow high-speed switching with minimum attenuation to the signal eye diagram with very little added jitter. Itconsumes < 2mW of power when operational and has a shutdown mode exercisable by EN pin resulting < 20uw.

The FUSB340TMX is available in QFN 2x3(X2-QFN-18) with Pb-free and Halogen-free making it a perfect candidate for mobile and space constrained applications.

Order Information

Package		Part Number	Top-Side Marking
QFN2x3(X2-QFN-18)	Tape and Reel	FUSB340TMX	A340 xxxx

Features

- Pin-to-Pin ASW3410, D103340, FUSB340
- Wide Supply Range 1.5 V to 5.5 V
- Differential 2:1 or 1:2 Switch/Multiplexer
- USB 3.1 Super Speed 10Gbps Switch
- High Bandwidth: 5.1GHz @-3dB Bandwidth
- Isolation: -24dB @ 1.25 GHz
- Crosstalk: -34dB @ 1.25 GHz
- Low bit-to-bit skew, Bidirectional
- ESD Tolerance: 2kV HBM
- Powered Off Protection When VDD = 0 V
- 1.8-V Compatible Logic Inputs

Applications

- USB Type-C Ecosystem
- Desktop and Notebook PCs
- Server/Storage Area Networks
- PCI Express Backplanes
- Shared I/O Ports
- FPD LinkII and FPD LinkIII Switching



Block Diagram

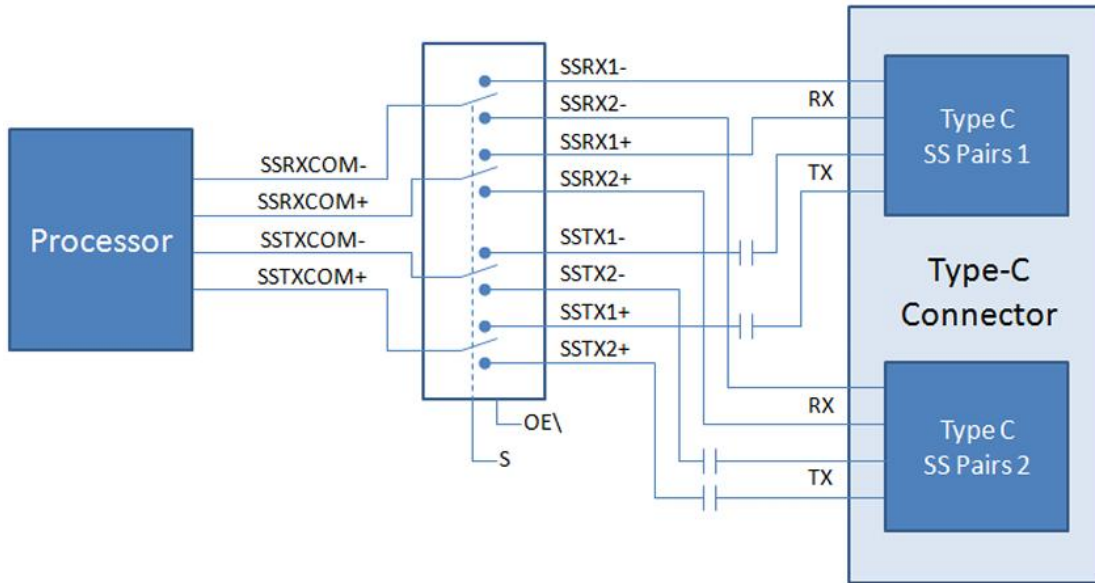

Fig.1 Block Diagram

Typical Application

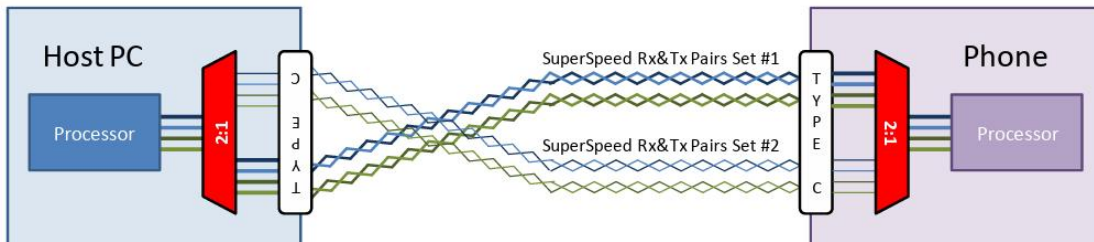

Fig.2 Typical Application



Pin Configuration

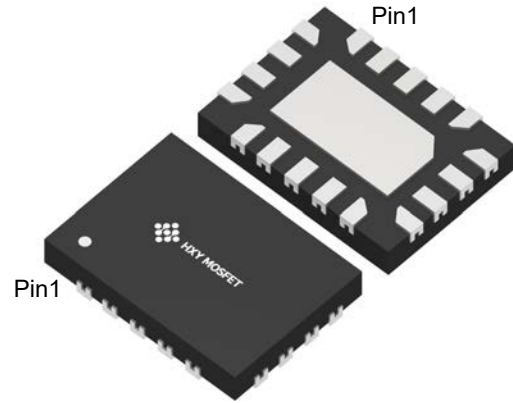
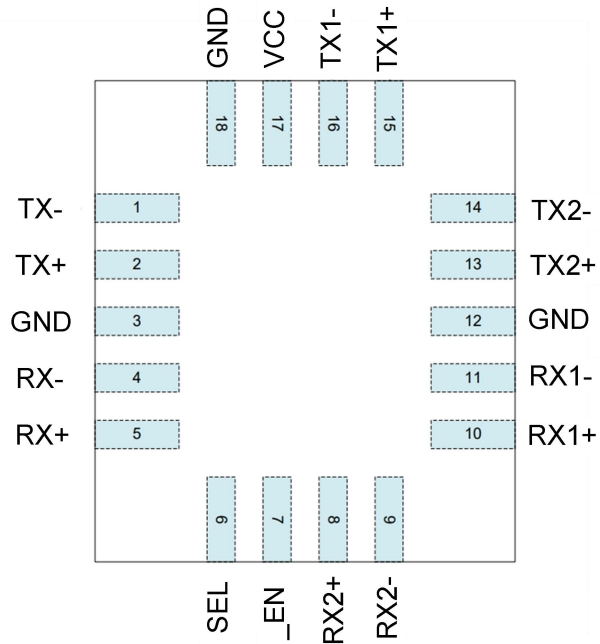

Fig.3 Pin Configuration

Pin Description

Pin#	Pin Name	Signal Type	Description
1	TX-	I/O	Super Speed TX- Common
2	TX+	I/O	Super Speed TX+ Common
3,12,18	GND	GND	Ground
4	RX-	I/O	Super Speed RX- Common
5	RX+	I/O	Super Speed RX+ Common
6	SEL	I	Switch logic control
7	_EN	I	Chip Enable, Active Low
8	RX2+	I/O	Super Speed RX2+
9	RX2-	I/O	Super Speed RX2-
10	RX1+	I/O	Super Speed RX1+
11	RX1-	I/O	Super Speed RX1-
13	TX2+	I/O	Super Speed TX2+
14	TX2-	I/O	Super Speed TX2-
15	TX1+	I/O	Super Speed TX1+
16	TX1-	I/O	Super Speed TX1-
17	VCC	Power	Supply Voltage

Table-1 Pin Description



Truth Table

_EN	SEL	TX+	TX-	RX+	RX-
High	X	Hi-Z	Hi-Z	Hi-Z	Hi-Z
Low	Low	TX1+	TX1-	RX1+	RX1-
Low	High	TX2+	TX2-	RX2+	RX2-

Table-2 Truth Table

Maximum Ratings

(Above which useful life may be impaired. For user guidelines, not tested.)

Storage Temperature	-65°C to +150°C
Junction Temperature	125°C
Supply Voltage to Ground Potential	-0.5V to +5.5V
Supere Speed Data Channel TX / RX	-0.5V to 3.8V
DC Input Voltage	-0.5V to VCC
DC Output Current	50mA
Power Dissipation	300mW

Table-3 Maximum Description

Notes:

Stresses greater than those listed under MAXIMUM RATINGS may cause permanent damage to the device. This is a stress rating only and functional operation of the device at these or any other conditions above those indicated in the operational sections of this specification is not implied. Exposure to absolute maximum rating conditions for extended periods may affect reliability.



Electrical Characteristics (Ta=25°C, VCC=1.8V, unless otherwise specified)

Parameter	Symbol	Conditions	Min.	Typ.	Max.	Unit
Power Supply						
VCC Quiescent Current	I _Q	SEL=0 or VCC, _EN=0		28		uA
Power-down Current	I _{PD}	SEL=0 or VCC, _EN=VCC			1	uA
DC Characteristics						
Input logic high	V _{IH}	VCC=1.8~4.5V	1.6			V
Input logic low	V _{IL}	VCC=1.8~4.5V			0.4	V
_EN Internal pull-up resistor	R _{UP}			2		MΩ
SEL Internal pull-down resistor	R _{DN}			2		MΩ
On-Resistance for TX/RX	R _{ON_HS}	V _{IS} = 0.2V I _{ON} =8mA		6.7	8	Ω
R _{ON} Flatness for TX/RX	R _{FLAT_LP}	V _{IS} = 0 to 1.2V I _{ON} =8mA		0.8	1	Ω
R _{ON} Flatness for TX/RX	R _{FLAT_LP}	V _{IS} = 0 to 0.2V I _{ON} =8mA		0.2	0.3	Ω
R _{ON} Matching Between Channels	R _{MATCH}	V _{IS} = 0 to 1.2V I _{ON} =8mA		0.1		Ω
Switch Off Leakage Current	I _{OFF}	_EN=VCC , Tx, Rx =VCC TX1, TX2, RX1, RX2=0	-0.5		0.5	uA
AC Characteristics						
Enable Time _EN to Output	t _{EN}	R _L =50Ω C _L =0pF V _{IS} = 0.6V		80	150	uS
Disable Time _EN to Output	t _{DIS}	R _L =50Ω C _L =0pF V _{IS} = 0.6V		40	250	nS
Turn-On Time SEL to Output	t _{ON}	R _L =50Ω C _L =0pF V _{IS} = 0.6V		400	1200	nS
Turn-Off Time SEL to Output	t _{OFF}	R _L =50Ω C _L =0pF V _{IS} = 0.6V		130	800	nS
Break-Before-Make Time	t _{BBM}	R _L =50Ω C _L =0pF V _{IS} = 0.6V		250	500	nS
Propagation Delay	t _{PD}	R _L =50Ω C _L =0pF V _{IS} = 0.6V		0.25		nS
Off Isolation	Off	R _L =50Ω f=1.2GHz V _{IS} = 0.2V _{PP}		-27		dB
Crosstalk	X _{TALK}	R _L =50Ω f=1.2GHz V _{IS} = 0.2V _{PP}		-43		dB
-3dB Bandwidth	BW _{-3dB}	R _L =50Ω C _L =0pF Signal 0dBm	4.5	5.1		GHz
Capacitance						
Switch On Capacitance	C _{ON}	V _{Bias} = 0.2V, f = 1.5GHz		1.5		pF
Switch Off Capacitance	C _{OFF}	V _{Bias} = 0.2V, f = 1.5GHz		1.0		pF

Table-4 Electrical Characteristics

Note:

- (1) Flatness is defined as the difference between maximum and minimum value of ON-resistance at the specified analog signal voltage points.
- (2) R_{ON} matching between channels is calculated by subtracting the channel with the lowest max Ron value from the channel with the highest max Ron value.
- (3) Crosstalk is inversely proportional to source impedance



Typical Performance Curves (Ta=25°C VCC=3.0V CAP=0.1μF unless otherwise noted)

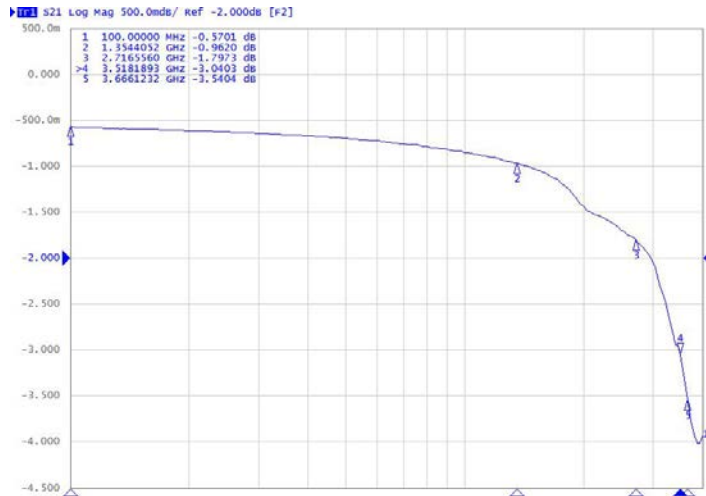

Fig.4 Switch Bandwidth or Insertion Loss

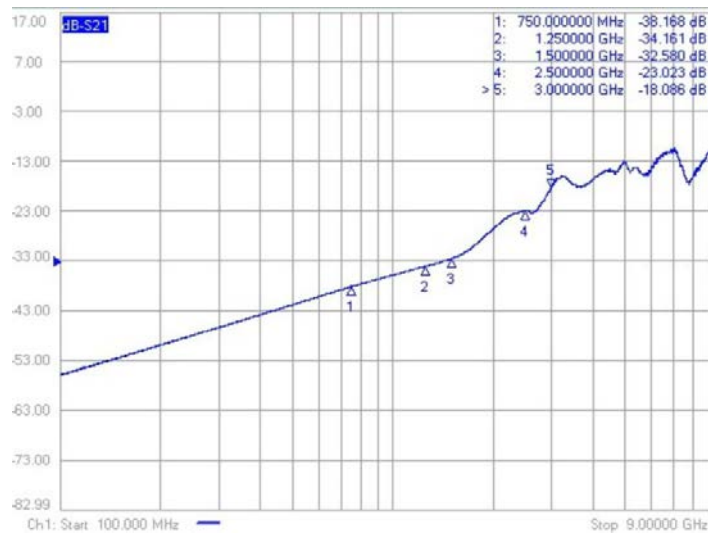

Fig.5 Switch Channel to Channel Cross-Talk



Fig.6 Switch Off Isolation



Package Outline Dimensions

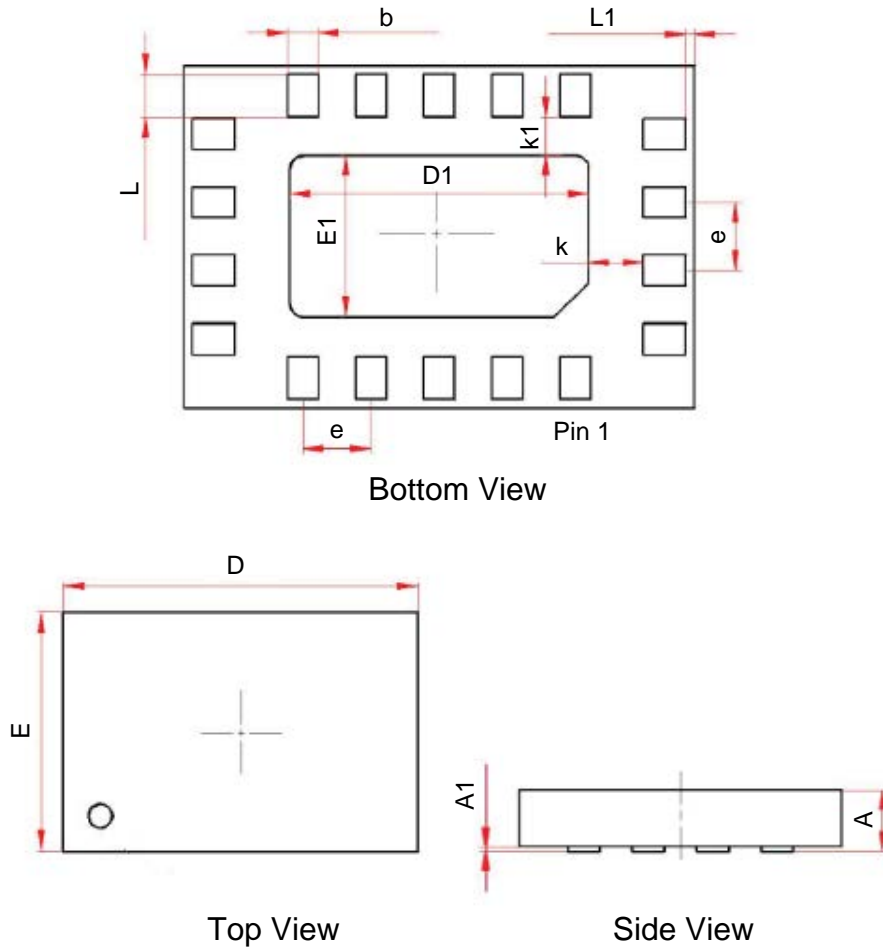

Symbol	Dimensions In Millimeters		
	Min.	Nom.	Max.
A	-	0.34	0.40
A1	-	0.01	0.05
D	3.00	2.95	3.05
E	2.00	1.95	2.05
D1	1.75	1.70	1.80
E1	0.95	0.90	1.00
b	0.18	0.15	0.21
L	0.25	0.20	0.30
L1	0.05	0.01	0.09
k	0.325 REF		
k1	0.225 REF		
e	0.400 BSC		



Attention

- Any and all HUA XUAN YANG ELECTRONICS products described or contained herein do not have specifications that can handle applications that require extremely high levels of reliability, such as life-support systems, aircraft's control systems, or other applications whose failure can be reasonably expected to result in serious physical and/or material damage. Consult with your HUA XUAN YANG ELECTRONICS representative nearest you before using any HUA XUAN YANG ELECTRONICS products described or contained herein in such applications.
- HUA XUAN YANG ELECTRONICS assumes no responsibility for equipment failures that result from using products at values that exceed, even momentarily, rated values (such as maximum ratings, operating condition ranges, or other parameters) listed in products specifications of any and all HUA XUAN YANG ELECTRONICS products described or contained herein.
- Specifications of any and all HUA XUAN YANG ELECTRONICS products described or contained herein stipulate the performance, characteristics, and functions of the described products in the independent state, and are not guarantees of the performance, characteristics, and functions of the described products as mounted in the customer's products or equipment. To verify symptoms and states that cannot be evaluated in an independent device, the customer should always evaluate and test devices mounted in the customer's products or equipment.
- HUA XUAN YANG ELECTRONICS CO.,LTD. strives to supply high-quality high-reliability products. However, any and all semiconductor products fail with some probability. It is possible that these probabilistic failures could give rise to accidents or events that could endanger human lives, that could give rise to smoke or fire, or that could cause damage to other property. When designing equipment, adopt safety measures so that these kinds of accidents or events cannot occur. Such measures include but are not limited to protective circuits and error prevention circuits for safe design, redundant design, and structural design.
- In the event that any or all HUA XUAN YANG ELECTRONICS products(including technical data, services) described or contained herein are controlled under any of applicable local export control laws and regulations, such products must not be exported without obtaining the export license from the authorities concerned in accordance with the above law.
- No part of this publication may be reproduced or transmitted in any form or by any means, electronic or mechanical, including photocopying and recording, or any information storage or retrieval system, or otherwise, without the prior written permission of HUA XUAN YANG ELECTRONICS CO.,LTD.
- Information (including circuit diagrams and circuit parameters) herein is for example only ; it is not guaranteed for volume production. HUA XUAN YANG ELECTRONICS believes information herein is accurate and reliable, but no guarantees are made or implied regarding its use or any infringements of intellectual property rights or other rights of third parties.
- Any and all information described or contained herein are subject to change without notice due to product/technology improvement, etc. When designing equipment, refer to the "Delivery Specification" for the HUA XUAN YANG ELECTRONICS product that you intend to use.