



产品编码 P/N	PDMCAT-Series	测试设备 TEST INSTRUMENT	Chroma: 3302 16502 Keysight: E4991
产品系列 Series	共模电感	测试频率 TEST FREQUENCY	参考参数页面

客户名称
Customer

客户编码
Customer P/N

产品系列
Series

共模电感
Common Mode Line Chokes

产品编码
Supply P/N

PDMCAT-Series

发版号
Version

A2.0

承认日期
Endorsement Date

2025-12-4

备注
Note

谱罗德电子科技（深圳）有限公司 PuLuoDe Electronic Technology (Shenzhen) Co. LTD	
制作 APPROVED	Ben
审查 CHECKED	Yuki
确认 PREPARED	Peter

客户承认

Customer Approval

* 烦请贵司在正式订单下达前确认回签本承诺书，否则敝司默认贵司认可本承诺书内的参数与条款，并以此参数生产交货

Please confirm and sign this acknowledgement letter before placing the formal order, otherwise PROD will acquiesce that your company recognizes the parameters and terms in this acknowledgement letter, and will produce and deliver according to these parameters.

客户签章



产品编码 P/N	PDMCAT-Series	测试设备 TEST INSTRUMENT	Chroma: 3302 16502 Keysight: E4991
产品系列 Series	共模电感	测试频率 TEST FREQUENCY	参考参数页面

产品特点

Features

- 多磁芯设计，锰锌/镍锌/非晶磁环，满足不同频段滤波需求
The material of the magnetic core can be selected according to the design requirements.
- 多种拓扑结构：卧式，立式，分绕，并绕，带底座，带底板，满足不同产品结构的设计需求
The assembly form of the inductor can be changed according to the design requirements.
- 丰富的尺寸感量规格，满足不同电流需求，不同尺寸需求设计
The inductance and size can be customized according to the design requirements.
- 高度自由化定制，可按照设计需求自由化定制，定制周期为1~5天
The customization of the inductor takes 1 to 5 days.

电路图

Schematic

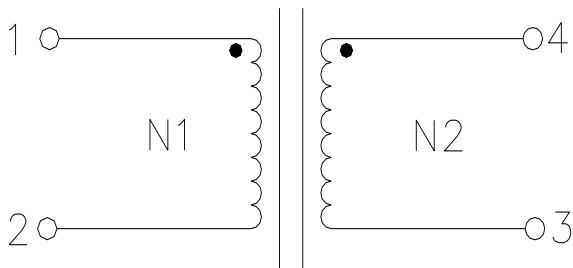

编码解释

Code interpretation

PDMCAT	XXXXX	-	XXX	X	X	X
类别码	尺寸系列		感值	精度	插件形式	组件形式
Category code	Dimension		Inductance	Tolerance	Shape	Subassembly

A系列=纳米非晶材料 N/T系列=镍锌材料

- 规格参数基于环境温度25°C取得，电感值随温度变化而改变，请务必将电感在25°环境下静置24小时后再测试电感量。
All test Data is referenced to 25°C ambient,the inductance varies with the ambient temperature.Before testing the inductance, let the inductor rest in a 25° environment for 24 hours.
- 部分规格电感值给出的“+∞”，则意味着该规格不规定电感值上限；尺寸标识符“Ref”则代表该尺寸为参考值，无明确的正负公差
∞=unlimited, Ref=It is merely a reference value and does not have positive or negative tolerance.
电感工作环境温度：-40°C ~ 105°C
Operating temperature range -40 °C to +105 °C
- 加载额定电流) 会使电感温度上升大约 40°C (电感初始温度+上升温度=电感最终温度)
Typical rated current would cause an approximately ΔT of 40°C
- 务必考虑最终的产品设计，元器件布局，线路板走线，及使用环境过程中，电感最终温度不得超过105°C
The operating temperature of inductance do not exceed 105°C
- 使用电感时，请注意阅读最后一页的注意事项
The announcements is on last page



产品编码 P/N	PDMCAT-Series	测试设备 TEST INSTRUMENT	Chroma: 3302 16502 Keysight: E4991
产品系列 Series	共模电感	测试频率 TEST FREQUENCY	参考参数页面

封装尺寸 Dimension

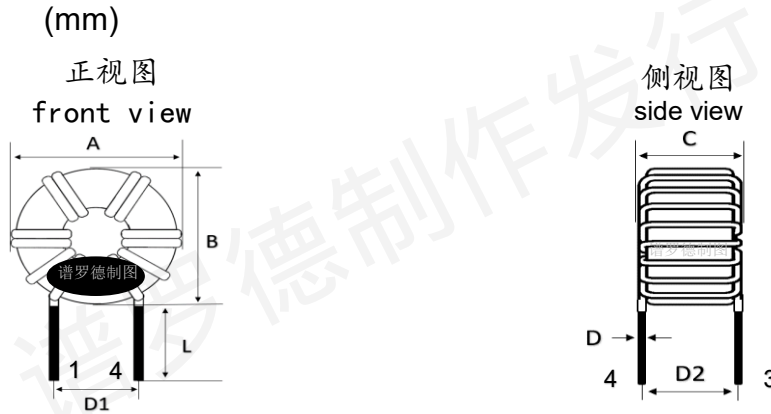

系列	封装尺寸							MPQ
	Dimension							
Series	A	B	C	D	D1	D2	L	袋装/Bag
953	12 Max	11 Max	6.0 Max	0.5±0.05	4.0 Ref	4.5 Ref	3.0 Min	300

电气参数

Electrical Characteristics

产品编码 P/N	@ 25 °C Ambient Temperature				
	感值 Inductance	精度 Tolerance	DCR	额定电流 rated current	耐压 HI-POT
	μH @1KHZ/0.3V	N1/N2 +/-	mΩ Max	A ΔT≈40°C	N1 vs N2 or N1/N2 vs Core AC/60Hz1mA 3Sec
PDMCAT953-220MLN	22	+∞/-20%	10	8	1.5KV

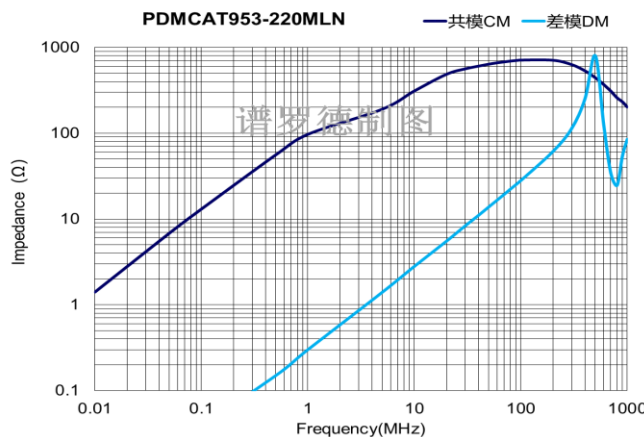

产品编码 P/N	PDMCAT-Series	测试设备 TEST INSTRUMENT	Chroma: 3302 16502 Keysight: E4991
产品系列 Series	共模电感	测试频率 TEST FREQUENCY	参考参数页面

封装尺寸 Dimension (mm)

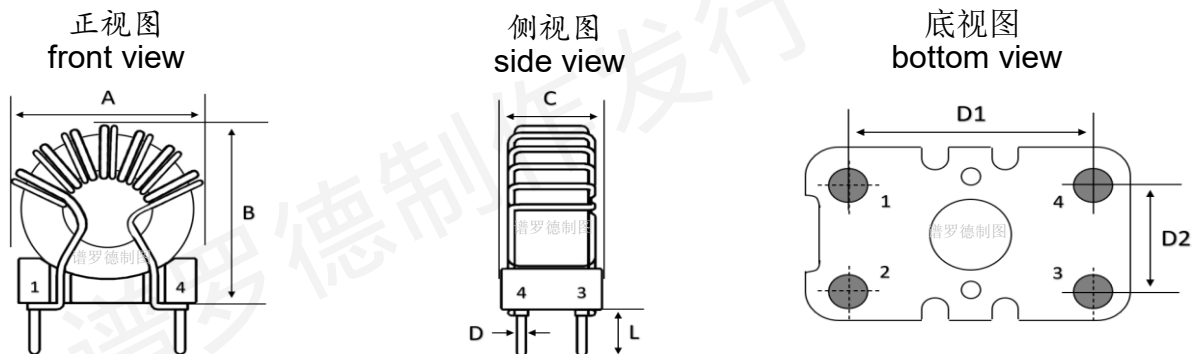

系列	封装尺寸 Dimension							MPQ
Series	A	B	C	D	D1	D2	L	吸塑盒/Tray
953	12Max	14 Max	7.5 Max	0.6±0.1	6.0 Ref	3.0 Ref	2.5 Min	180

电气参数

Electrical Characteristics

产品编码 P/N	@ 25 °C Ambient Temperature				
	感值 Inductance	精度 Tolerance	DCR	额定电流 rated current	耐压 HI-POT
	uH @1KHZ/0.3V	N1/N2 +/-	mΩ Max	A ΔT≈40°C	N1 vs N2 or N1/N2 vs Core AC/60Hz1mA 3Sec
PDMCAT953-201MLB-D	200	+∞/-20%	13	6	1.5KV

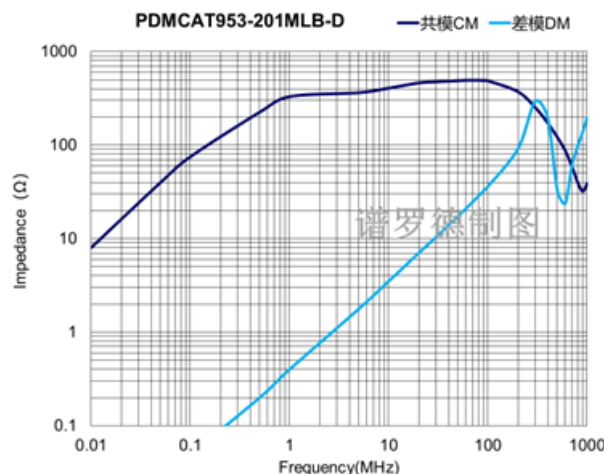

产品编码 P/N	PDMCAT-Series	测试设备 TEST INSTRUMENT	Chroma: 3302 16502 Keysight: E4991
产品系列 Series	共模电感	测试频率 TEST FREQUENCY	参考参数页面

封装尺寸 Dimension

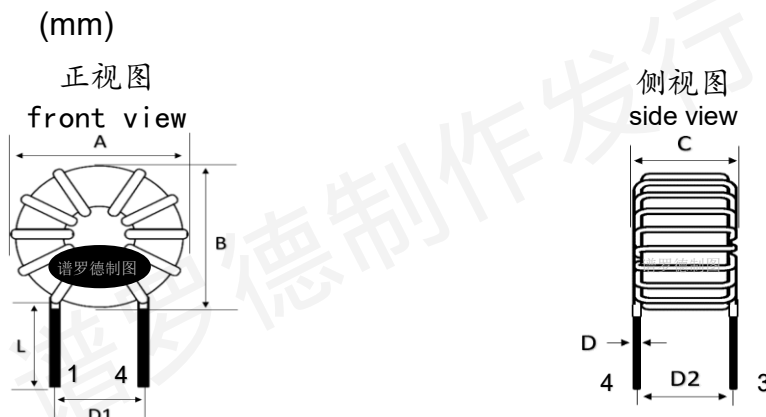

系列	封装尺寸							MPQ
	Dimension							
Series	A	B	C	D	D1	D2	L	袋装/Bag
953	12 Max	11 Max	6.0 Max	0.5±0.05	4.0 Ref	4.5 Ref	3.0 Min	300

电气参数

Electrical Characteristics

产品编码 P/N	@ 25 °C Ambient Temperature				
	感值 Inductance	精度 Tolerance	DCR	额定电流 rated current	耐压 HI-POT
	uH @1KHZ/0.3V	N1/N2 +/-	mΩ Max	A ΔT≈40°C	N1 vs N2 or N1/N2 vs Core AC/60Hz1mA 3Sec
PDMCAT953-501MLN	500	+∞/-20%	16	6	600V

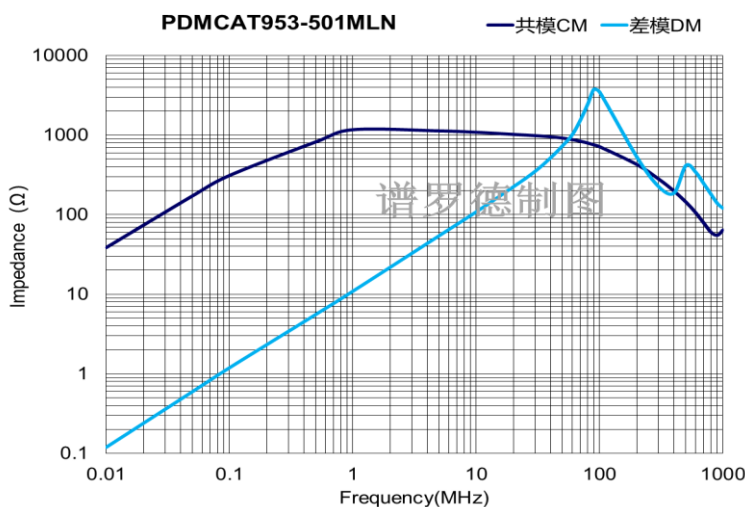

产品编码 P/N	PDMCAT-Series	测试设备 TEST INSTRUMENT	Chroma: 3302 16502 Keysight: E4991
产品系列 Series	共模电感	测试频率 TEST FREQUENCY	参考参数页面

封装尺寸 Dimension

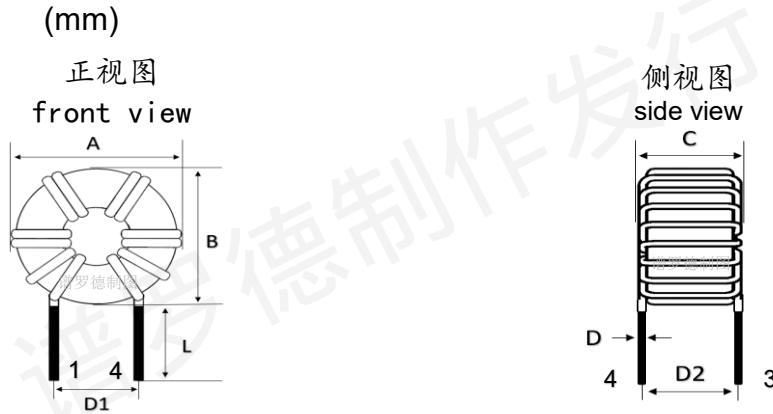

系列	封装尺寸							MPQ
	Dimension							
Series	A	B	C	D	D1	D2	L	袋装/Bag
953	12 Max	11 Max	6.0 Max	0.4±0.05	4.0 Ref	4.5 Ref	3.0 Min	300

电气参数

Electrical Characteristics

产品编码 P/N	@ 25 °C Ambient Temperature				
	感值 Inductance	精度 Tolerance	DCR	额定电流 rated current	耐压 HI-POT
	mH	N1/N2	mΩ	A	N1 vs N2 or N1/N2 vs Core
	@1KHZ/0.3V	+/-	Max	ΔT≈40°C	AC/60Hz1mA 3Sec
PDMCAT953-102MLN	1	+∞/-20%	22	4	1.5KV

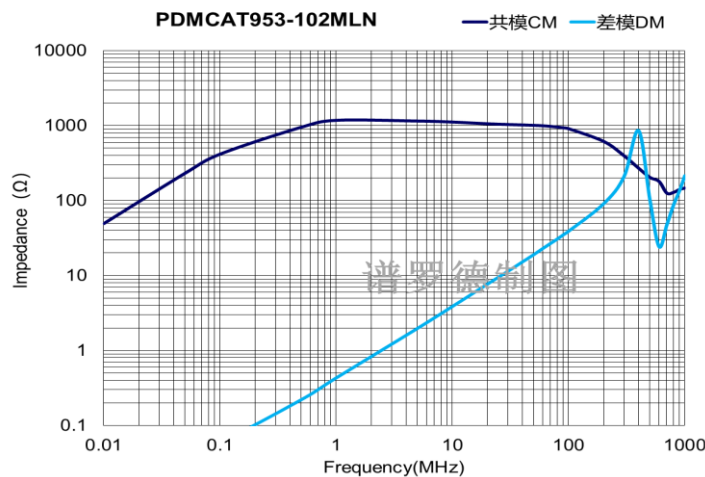

产品编码 P/N	PDMCAT-Series	测试设备 TEST INSTRUMENT	Chroma: 3302 16502 Keysight: E4991
产品系列 Series	共模电感	测试频率 TEST FREQUENCY	参考参数页面

封装尺寸 Dimension

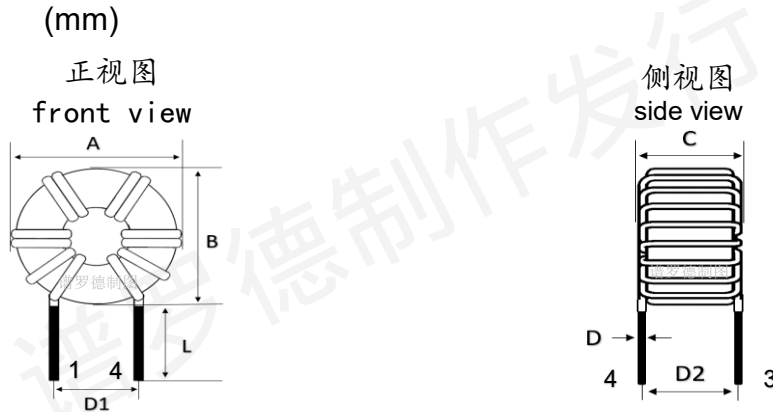

系列	封装尺寸							MPQ
	Dimension							
Series	A	B	C	D	D1	D2	L	吸塑盒/Tray
1065	13 Max	13 Max	7.5 Max	0.6±0.1	5.0 Ref	6.0 Ref	3.0 Min	300

电气参数

Electrical Characteristics

产品编码 P/N	@ 25 °C Ambient Temperature				
	感值 Inductance	精度 Tolerance	DCR	额定电流 rated current	耐压 HI-POT
	μH	N1/N2	mΩ	A	N1 vs N2 or N1/N2 vs Core
	@1KHZ/0.3V	+/-	Max	ΔT≈40°C	AC/60Hz/1mA 3Sec
PDMCAT1065-501MLN	500	+∞/-20%	15	8	600V

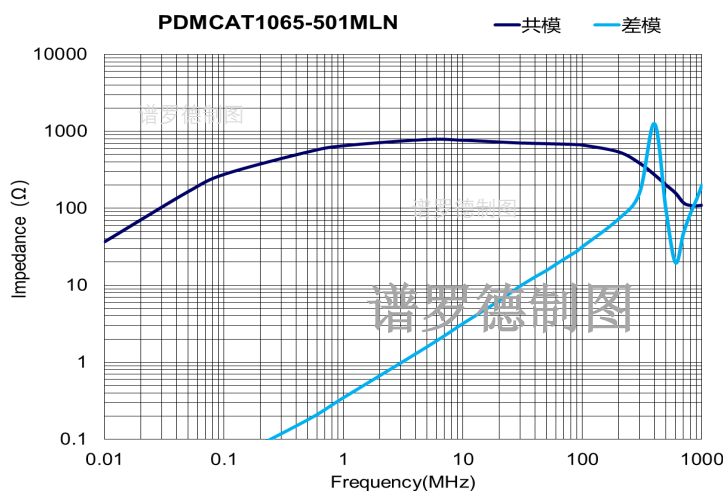

产品编码 P/N	PDMCAT-Series	测试设备 TEST INSTRUMENT	Chroma: 3302 16502 Keysight: E4991
产品系列 Series	共模电感	测试频率 TEST FREQUENCY	参考参数页面

封装尺寸 Dimension

(mm)

正视图
front view

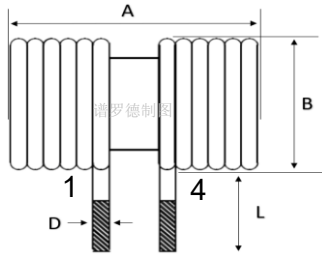

底视图
bottom view

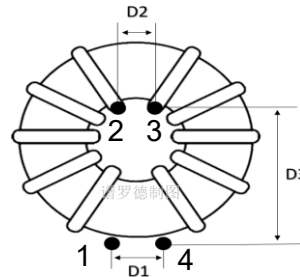

系列	封装尺寸							MPQ
	Dimension							
Series	A	B	D	D1	D2	D3	L	吸塑盒/Tray
1065	13 Max	7.5 Max	0.6±0.1	5.0 Ref	3.0 Ref	8.0 Ref	3.0 Min	300

电气参数

Electrical Characteristics

产品编码 P/N	@ 25 °C Ambient Temperature				
	感值 Inductance	精度 Tolerance	DCR	额定电流 rated current	耐压 HI-POT
	mH @1KHZ/0.3V	N1/N2 +/-	mΩ Max	A ΔT≈40°C	N1 vs N2 or N1/N2 vs Core AC/60Hz1mA 3Sec
PDMCAT1065-102MWN	1	+∞/-20%	17	6	600V

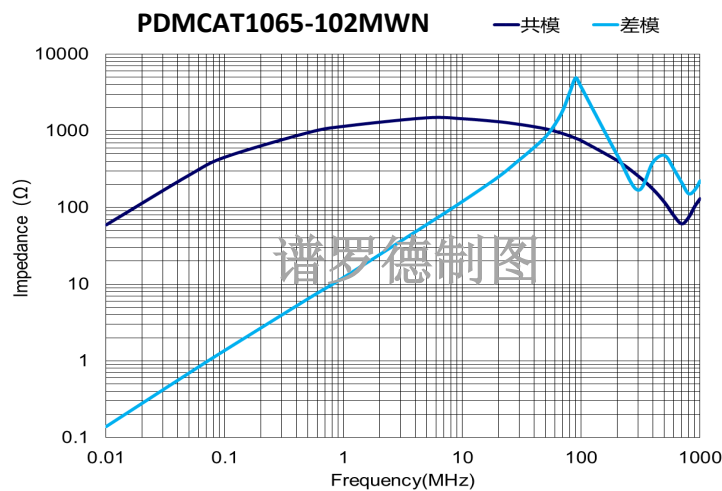

产品编码 P/N	PDMCAT-Series	测试设备 TEST INSTRUMENT	Chroma: 3302 16502 Keysight: E4991
产品系列 Series	共模电感	测试频率 TEST FREQUENCY	参考参数页面

封装尺寸 Dimension

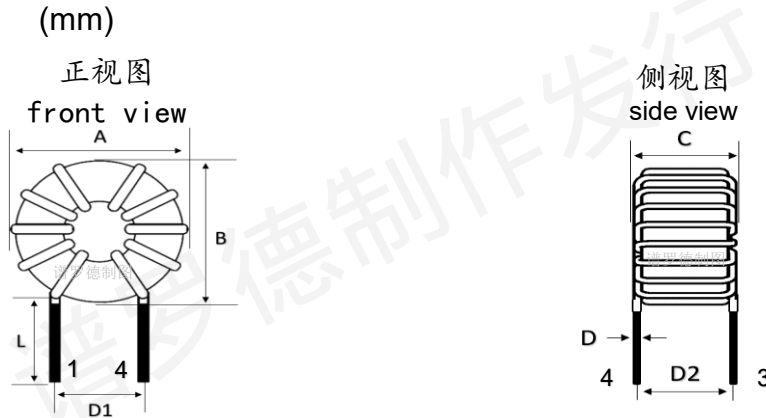

系列	封装尺寸							MPQ
	Dimension							
Series	A	B	C	D	D1	D2	L	吸塑盒/Tray
1065	13 Max	13 Max	7.5 Max	0.6±0.1	5.0 Ref	6.0 Ref	3.0 Min	300

电气参数

Electrical Characteristics

产品编码 P/N	@ 25 °C Ambient Temperature				
	感值 Inductance	精度 Tolerance	DCR	额定电流 rated current	耐压 HI-POT
	mH	N1/N2	mΩ	A	N1 vs N2 or N1/N2 vs Core
	@1KHZ/0.3V	+/-	Max	ΔT≈40°C	AC/60Hz1mA 3Sec
PDMCAT1065-102MLN	1	+∞/-20%	17	6	600V

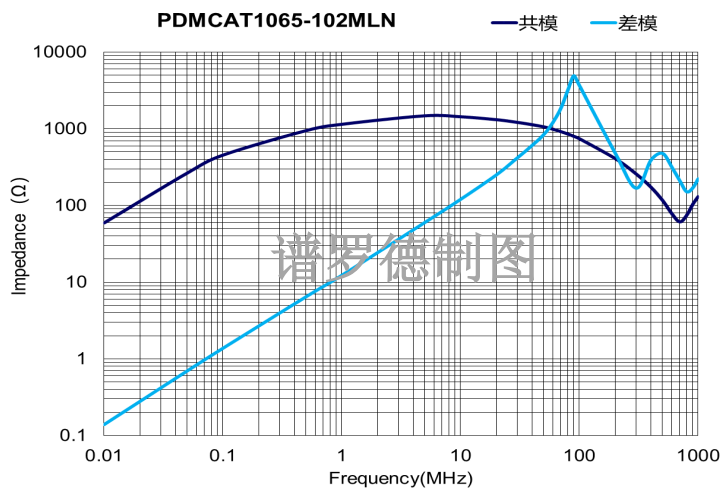

产品编码 P/N	PDMCAT-Series	测试设备 TEST INSTRUMENT	Chroma: 3302 16502 Keysight: E4991
产品系列 Series	共模电感	测试频率 TEST FREQUENCY	参考参数页面

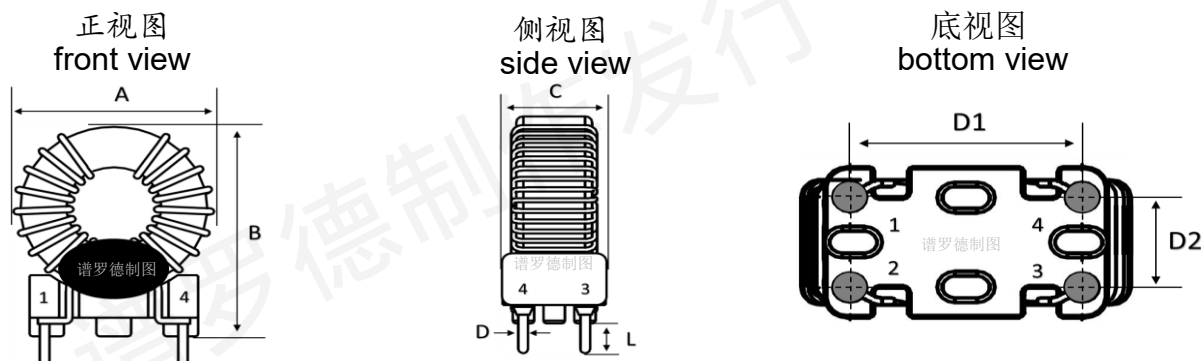
封装尺寸
Dimension (mm)

系列	封装尺寸 Dimension							MPQ
Series	A	B	C	D	D1	D2	L	吸塑盒/Tray
1265	14.5Max	17 Max	9.0 Max	0.7±0.1	10.0 Ref	4.5 Ref	2.5 Min	130

电气参数

Electrical Characteristics

产品编码 P/N	@ 25 °C Ambient Temperature				
	感值 Inductance	精度 Tolerance	DCR	额定电流 rated current	耐压 HI-POT
	uH @1KHZ/0.3V	N1/N2 +/-	mΩ Max	A ΔT≈40°C	N1 vs N2 or N1/N2 vs Core AC/60Hz1mA 3Sec
PDMCAT1265T-100NLB	10	±30%	16	6	600V
PDMCAT1265T-200NLB	20	±30%	32	4	600V
PDMCAT1265T-330NLB	33	±30%	40	3.5	600V
PDMCAT1265T-500NLB	50	±30%	100	2.3	600V
PDMCAT1265T-101NLB	100	±30%	140	1.8	600V

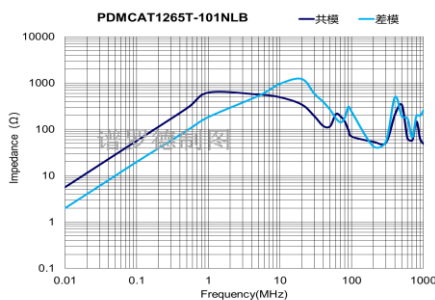
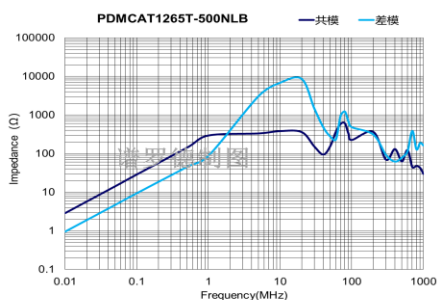
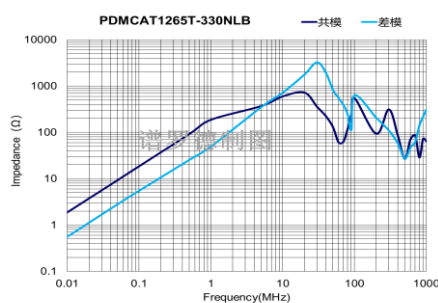
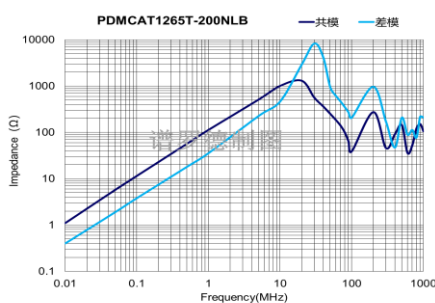
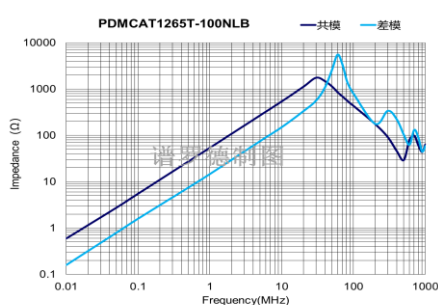

产品编码 P/N	PDMCAT-Series	测试设备 TEST INSTRUMENT	Chroma: 3302 16502 Keysight: E4991
产品系列 Series	共模电感	测试频率 TEST FREQUENCY	参考参数页面

封装尺寸 Dimension (mm)

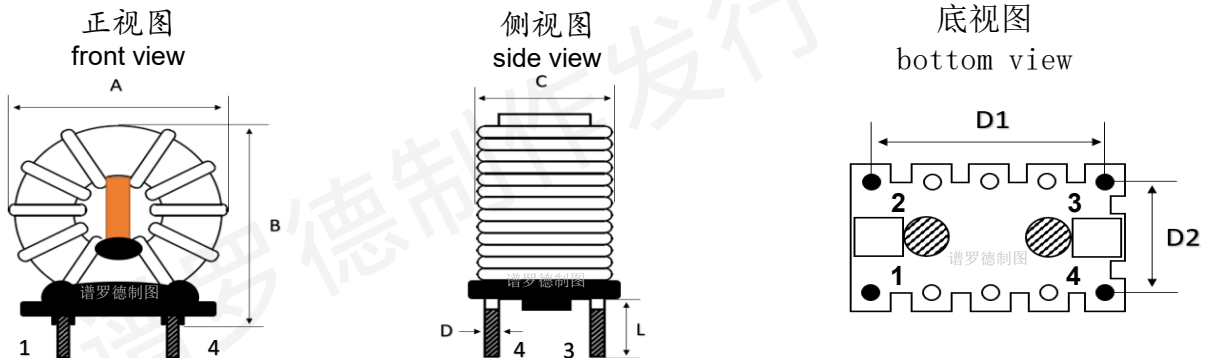

系列	封装尺寸 Dimension							MPQ
Series	A	B	C	D	D1	D2	L	吸塑盒/Tray
1386	17 Max	18 Max	9.6 Max	0.65±0.1	10.0 Ref	5.0 Ref	4.0 Min	300

电气参数

Electrical Characteristics

产品编码 P/N	@ 25 °C Ambient Temperature				
	感值 Inductance	精度 Tolerance	DCR	额定电流 rated current	耐压 HI-POT
	mH @1KHZ/0.3V	N1/N2 +/-	mΩ Max	A ΔT≈40°C	N1 vs N2 or N1/N2 vs Core AC/60Hz1mA 3Sec
PDMCAT1386-102ML	1	+∞/-20%	20	3	1.5KV
PDMCAT1386-222ML	2.2	+∞/-20%	30	3	1.5KV
PDMCAT1386-472ML	4.7	+∞/-20%	70	2	1.5KV
PDMCAT1386-103ML	10	+∞/-20%	140	1	1.5KV
PDMCAT1386-153ML	15	+∞/-20%	180	1	1.5KV
PDMCAT1386-203ML	20	+∞/-20%	230	1	1.5KV

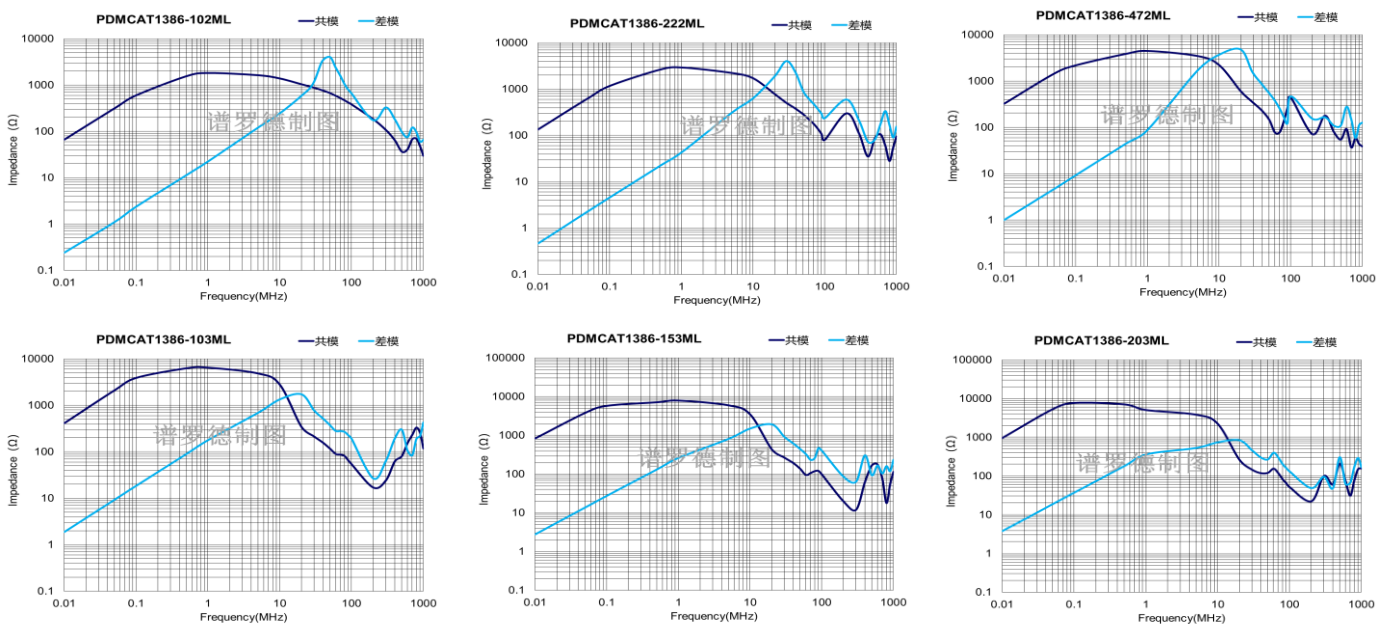



产品编码 P/N	PDMCAT-Series	测试设备 TEST INSTRUMENT	Chroma: 3302 16502 Keysight: E4991
产品系列 Series	共模电感	测试频率 TEST FREQUENCY	参考参数页面

封装尺寸 (mm)
Dimension

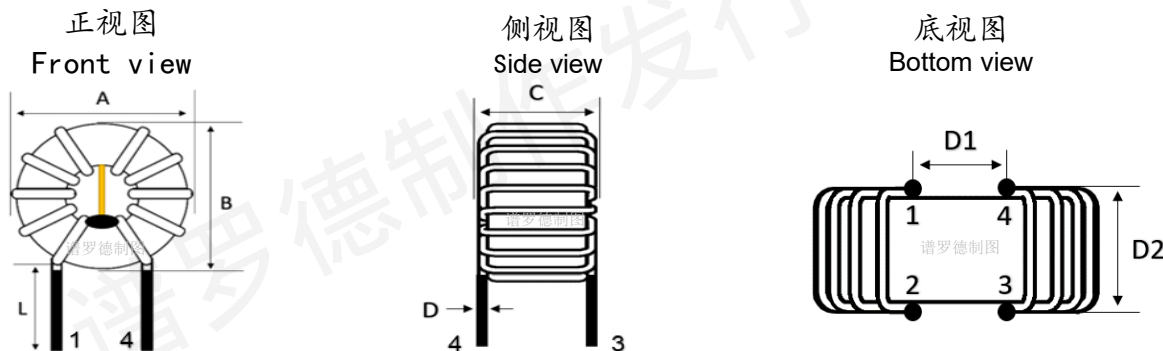

系列	封装尺寸							MPQ	重量 /weight
	Dimension								
Series	A	B	C	D	D1	D2	L	吸塑盒/Tray	g
1487	17.5 Max	16 Max	11.5 Max	0.7±0.1	8.0 Ref	9.0 Ref	6.0 Min	130	6.2

电气参数

Electrical Characteristics

产品编码 P/N	@ 25 °C Ambient Temperature				
	感值	精度	DCR	额定电流	耐压
	Inductance	Tolerance		rated current	HI-POT
	N1/N2	N1/N2	mΩ	A	N1 vs N2 or N1/N2 vs Core
	mH	+/-	Max	ΔT≈40°C	AC/60Hz1mA 3Sec
PDMCAT1487-302MLN	3	+∞/-20%	20	6	600V

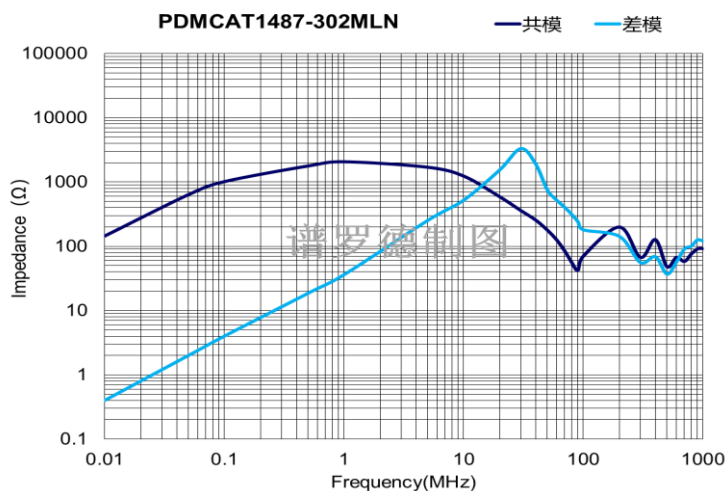

谱罗德电子科技（深圳）有限公司
PuLuoDe Electronic Technology (Shenzhen) Co., LTD
深圳市宝安区石岩三联工业区B栋311

更多规格请访问谱罗德官方网站
下载或者扫描二维码通过微信小程序
获取

<http://www.prodtch.cn/>



产品编码 P/N	PDMCAT-Series	测试设备 TEST INSTRUMENT	Chroma: 3302 16502 Keysight: E4991
产品系列 Series	共模电感	测试频率 TEST FREQUENCY	参考参数页面

封装尺寸
Dimension (mm)

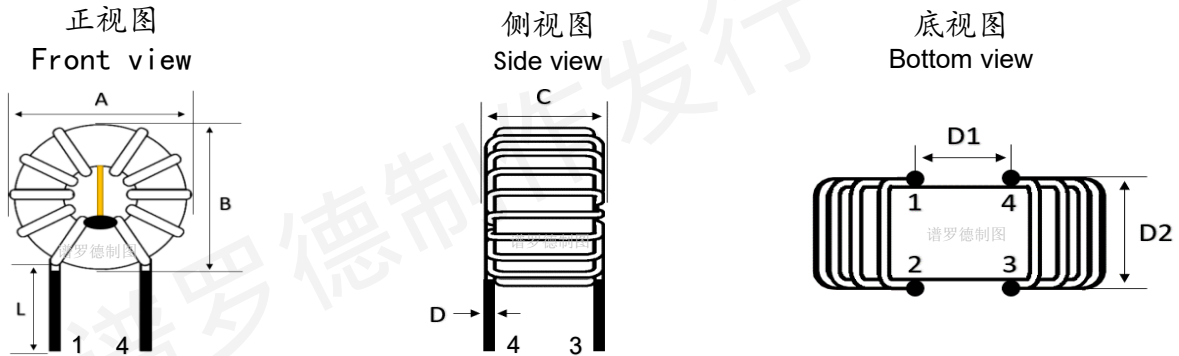

系列 Series	封装尺寸 Dimension							MPQ
	A	B	C	D	D1	D2	L	吸塑盒/Tray
16128	20 Max	18 Max	12 Max	见下列	8.0 Ref	10.0 Ref	8.0 Min	96

电气参数

Electrical Characteristics

产品编码 P/N	@ 25 °C Ambient Temperature						耐压 HI-POT N1~N2/N1N2~Core AC/60Hz/1mA 3Sec
	感值 Inductance	精度 Tolerance	DCR	额定电流 rated current	D尺寸		
	mH @1KHZ/0.3V	N1/N2 +/-	mΩ Max	A ΔT≈40°C			
PDMCAT16128-102ML	1	+∞/-20%	13	10	1.0±0.1	600V	
PDMCAT16128-202ML	2	+∞/-20%	32	6	0.7±0.1		
PDMCAT16128-502ML	5	+∞/-20%	50	5	0.65±0.05		
PDMCAT16128-103ML	10	+∞/-20%	75	3	0.6±0.05		
PDMCAT16128-203ML	20	+∞/-20%	130	2.5	0.5±0.05		

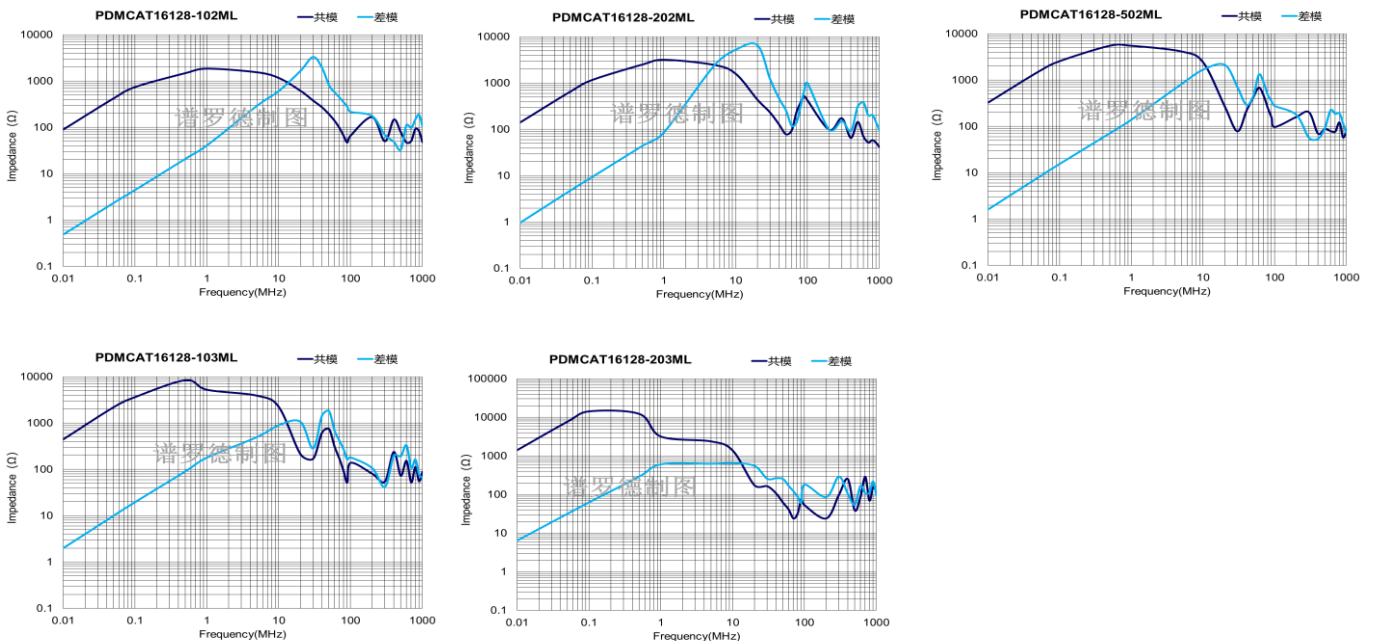

产品编码 P/N	PDMCAT1386-221413series	测试设备 TEST INSTRUMENT	Chroma: 3302 16502 Keysight: E4991
产品系列 Series	共模电感	测试频率 TEST FREQUENCY	1KHZ / 0.3V

封装尺寸
Dimension

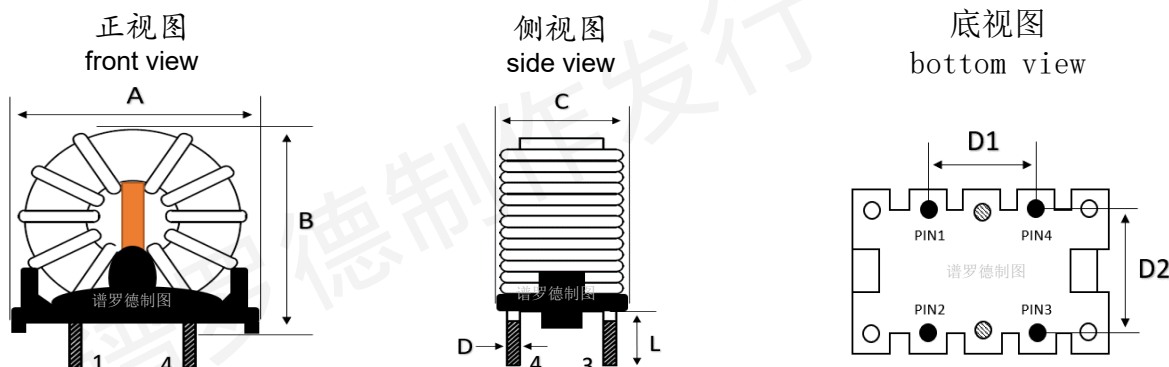

系列	封装尺寸 Dimension							MPQ
Series	A	B	C	D	D1	D2	L	吸塑盒/Tray
16128	22 Max	22 Max	14 Max	1.0±0.1	7.5 Ref	9.0 Ref	5.0 Min	180

电气参数

Electrical Characteristics

产品编码 P/N	@ 25 °C Ambient Temperature				
	感值 Inductance	精度 Tolerance	DCR	额定电流 rated current	耐压 HI-POT
	mH @1KHZ/0.3V	N1/N2 +/-	mΩ Max	A ΔT≈40°C	N1 vs N2 or N1/N2 vs Core AC/60Hz1mA 3Sec
PDMCAT16128-102MLB	1	+∞/-20%	14	9	1.5KV
PDMCAT16128-202MLB	2	+∞/-20%	25	6	1.5KV
PDMCAT16128-502MLB	5	+∞/-20%	40	5	1.5KV
PDMCAT16128-103MLB	10	+∞/-20%	60	3.5	1.5KV
PDMCAT16128-153MLB	15	+∞/-20%	80	3	1.5KV
PDMCAT16128-203MLB	20	+∞/-20%	130	2.5	1.5KV

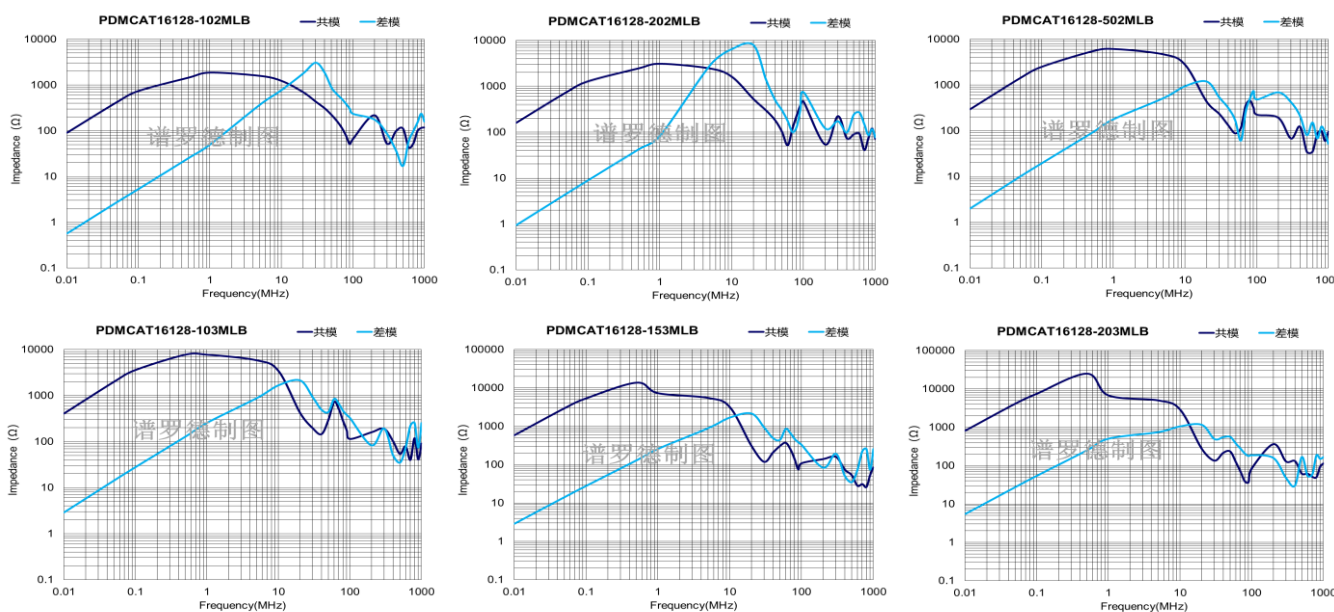

谱罗德电子科技(深圳)有限公司
PuLuoDe Electronic Technology (Shenzhen) Co., LTD
深圳市宝安区石岩三联工业区B栋311

更多规格请访问谱罗德官方网站
下载或者扫描二维码通过微信小程序获取
<http://www.prodtech.cn/>



产品编码 P/N	PDMCAT-Series	测试设备 TEST INSTRUMENT	Chroma: 3302 16502 Keysight: E4991
产品系列 Series	共模电感	测试频率 TEST FREQUENCY	参考参数页面

封装尺寸 (mm)
Dimension

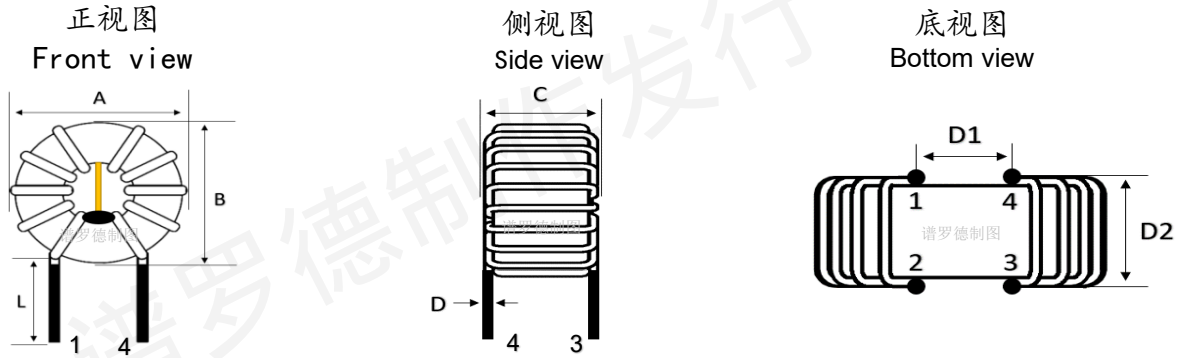

系列 Series	封装尺寸 Dimension							MPQ
	A	B	C	D	D1	D2	L	吸塑盒/Tray
18107	22 Max	20 Max	12 Max	见下列	8.0 Ref	9.0 Ref	8.0 Min	96

电气参数

Electrical Characteristics

产品编码 P/N	@ 25 °C Ambient Temperature						耐压 HI-POT N1~N2/N1&N2-C AC/60Hz1mA 3Sec
	感值 Inductance	精度 Tolerance	DCR	额定电流 rated current	D尺寸		
	mH @1KHZ/0.3V	N1/N2 +/-	mΩ Max	A ΔT≈40°C			
PDMCAT18107-102ML	1	+∞/-20%	6	15	1.2±0.1	600V	
PDMCAT18107-202ML	2	+∞/-20%	12	10	1.0±0.1		
PDMCAT18107-502ML	5	+∞/-20%	25	7	0.75±0.1		
PDMCAT18107-103ML	10	+∞/-20%	55	3.5	0.6±0.05		
PDMCAT18107-203ML	20	+∞/-20%	110	3	0.5±0.05		

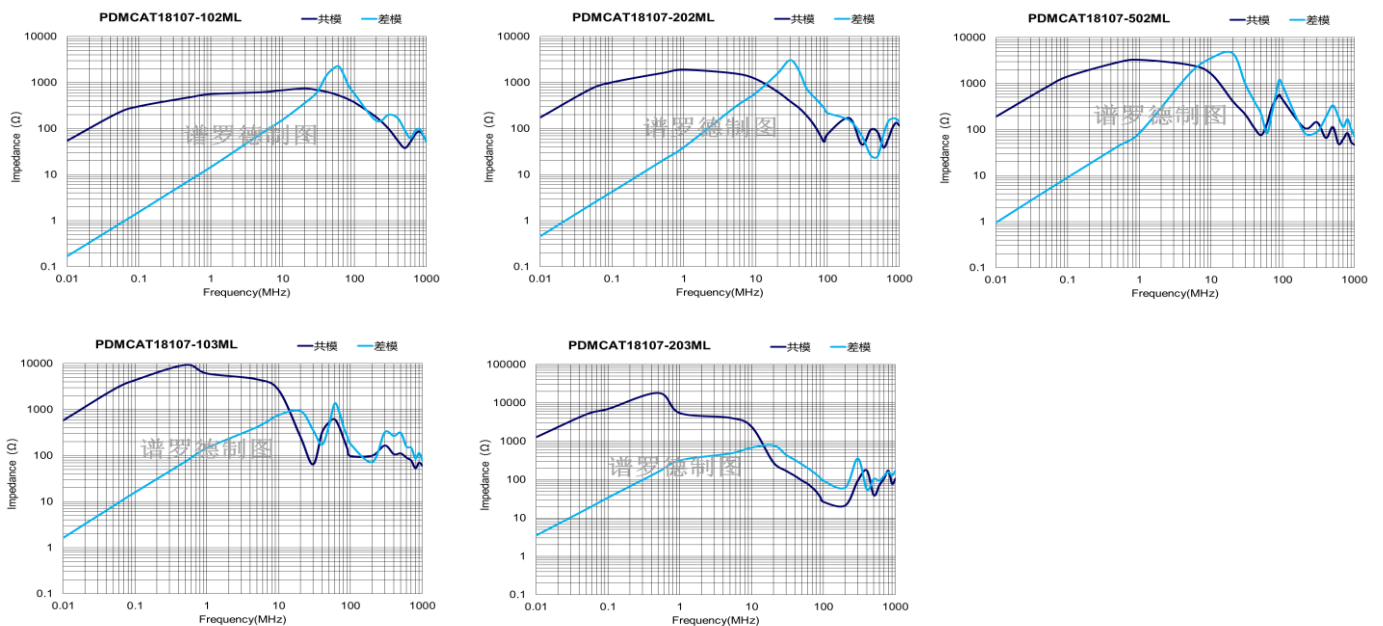

产品编码 P/N	PDMCAT1386-221413series	测试设备 TEST INSTRUMENT	Chroma: 3302 16502 Keysight: E4991
产品系列 Series	共模电感	测试频率 TEST FREQUENCY	1KHZ / 0.3V

封装尺寸 Dimension (mm)

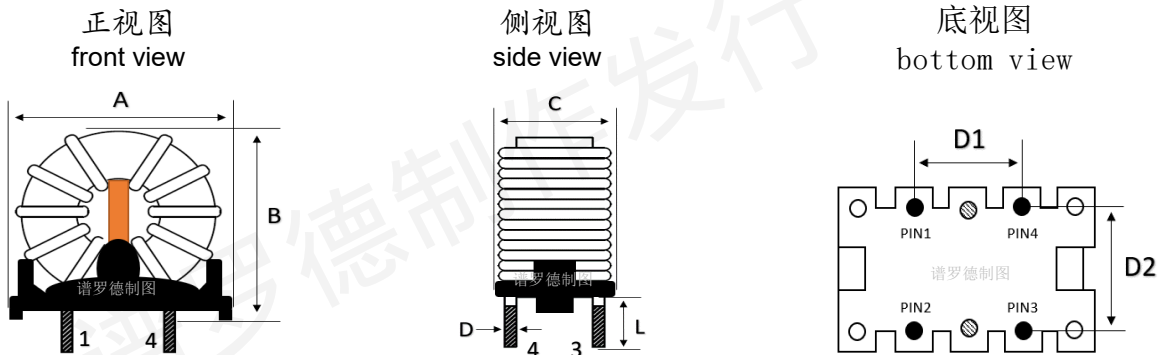

系列	封装尺寸 Dimension							MPQ
Series	A	B	C	D	D1	D2	L	吸塑盒/Tray
18107	23 Max	24 Max	15 Max	1.0±0.1	7.5±0.5	9.0±0.5	4.0 Min	152

电气参数

Electrical Characteristics

产品编码 P/N	@ 25 °C Ambient Temperature				
	感值 Inductance	精度 Tolerance	DCR	额定电流 rated current	耐压 HI-POT
	mH @1KHZ/0.3V	N1/N2 +/-	mΩ Max	A ΔT≈40°C	N1 vs N2 or N1/N2 vs Core AC/60Hz1mA 3Sec
PDMCAT18107-102MLB	1	+∞/-20%	9	10	1.5KV
PDMCAT18107-202MLB	2	+∞/-20%	16	8	1.5KV
PDMCAT18107-502MLB	5	+∞/-20%	30	6	1.5KV
PDMCAT18107-103MLB	10	+∞/-20%	60	4.5	1.5KV
PDMCAT18107-153MLB	15	+∞/-20%	80	3.5	1.5KV
PDMCAT18107-203MLB	20	+∞/-20%	100	3	1.5KV
PDMCAT18107-303MLB	30	+∞/-20%	150	2.5	1.5KV

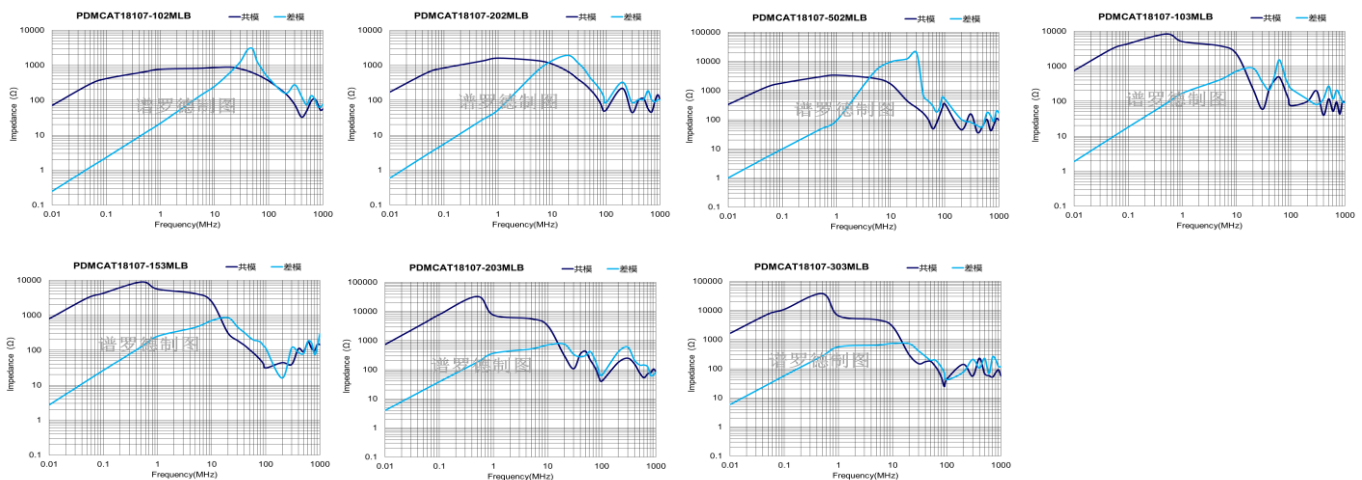

产品编码 P/N	PDMCAT-Series	测试设备 TEST INSTRUMENT	Chroma: 3302 16502 Keysight: E4991
产品系列 Series	共模电感	测试频率 TEST FREQUENCY	参考参数页面

封装尺寸 (mm)
Dimension

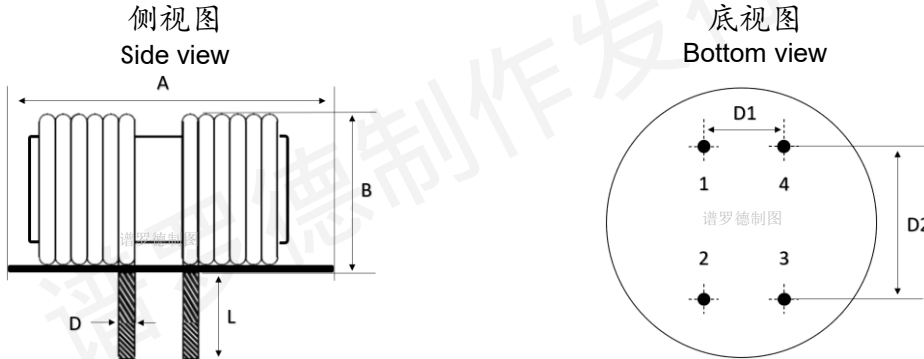

系列 Series	封装尺寸 Dimension							MPQ
	A	B	D	L	D1	D2	*	吸塑盒/Tray
18107	26.5Max	12.5Max	*±0.1	5.0±1	6.7±1	14.0±1	*	100

电气参数

Electrical Characteristics

产品编码 P/N	@ 25 °C Ambient Temperature						耐压 HI-POT N1~N2/N1&N2-C AC/60Hz1mA 3Sec
	感值 Inductance	精度 Tolerance	DCR	额定电流 rated current	D尺寸		
	mH	N1/N2	mΩ	A			
	@1KHZ/0.3V	+/-	Max	ΔT≈40°C			
PDMCAT18107-102MWG	1	+∞/-20%	6	15	1.2±0.1	600V	
PDMCAT18107-202MWG	2	+∞/-20%	12	10	1.0±0.1		
PDMCAT18107-502MWG	5	+∞/-20%	25	7	0.75±0.1		
PDMCAT18107-103MWG	10	+∞/-20%	55	3.5	0.6±0.05		
PDMCAT18107-203MWG	20	+∞/-20%	110	3	0.5±0.05		

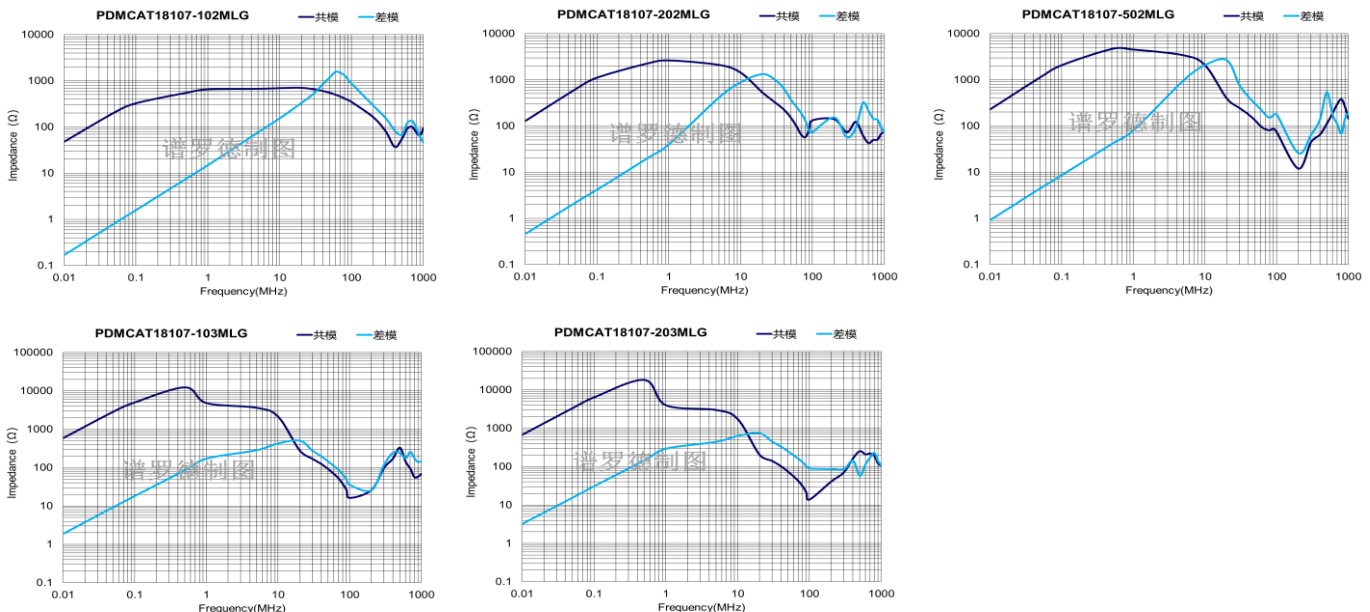

产品编码 P/N	PDMCAT-Series	测试设备 TEST INSTRUMENT	Chroma: 3302 16502 Keysight: E4991
产品系列 Series	共模电感	测试频率 TEST FREQUENCY	参考参数页面

封装尺寸 Dimension (mm)

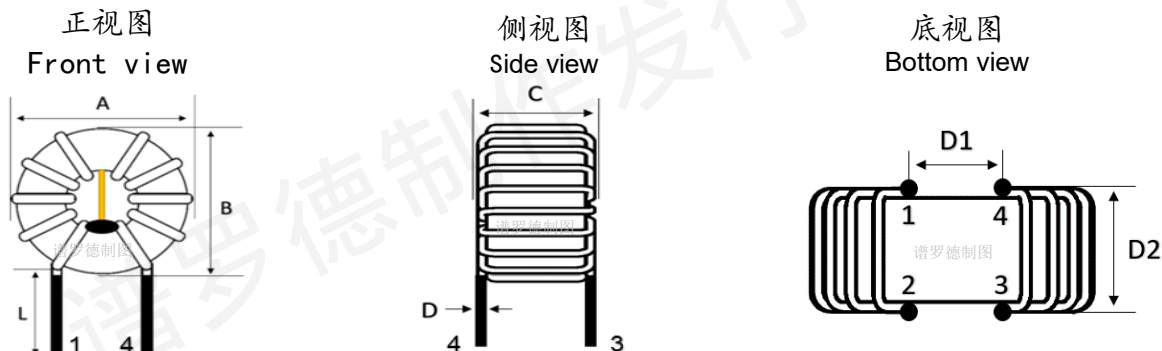

系列	封装尺寸 Dimension							MPQ	重量 /weight
	A	B	C	D	D1	D2	L		
Series	A	B	C	D	D1	D2	L	吸塑盒/Tray	g
201010	25 Max	23 Max	16 Max	0.8±0.1	9.0 Ref	11.0 Ref	6.0 Min	100	21.1

电气参数

Electrical Characteristics

产品编码 P/N	@ 25 °C Ambient Temperature				
	感值 Inductance	精度 Tolerance	DCR	额定电流 rated current	耐压 HI-POT
	N1/N2	N1/N2	mΩ	A	N1 vs N2 or N1/N2 vs Core
	mH	+/-	Max	$\Delta T \approx 40^\circ\text{C}$	AC/60Hz/1mA/3Sec
PDMCAT201010-103MLN	10	+∞/-20%	36	5	1KV

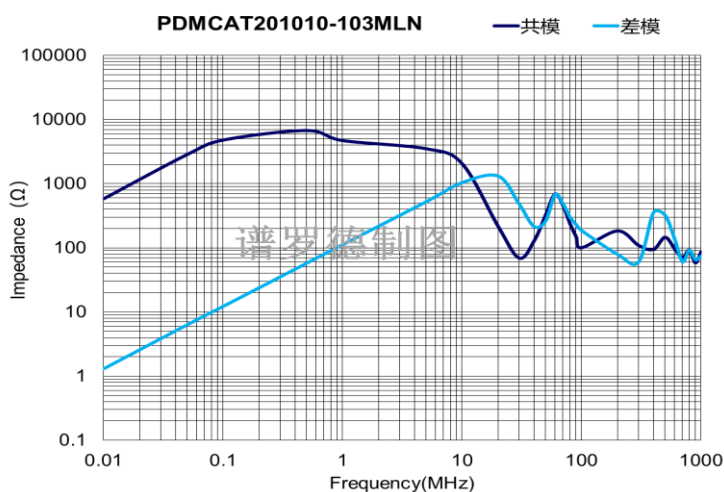

产品编码 P/N	PDMCAT1386-221413series	测试设备 TEST INSTRUMENT	Chroma: 3302 16502 Keysight: E4991
产品系列 Series	共模电感	测试频率 TEST FREQUENCY	1KHZ / 0.3V

封装尺寸 Dimension (mm)

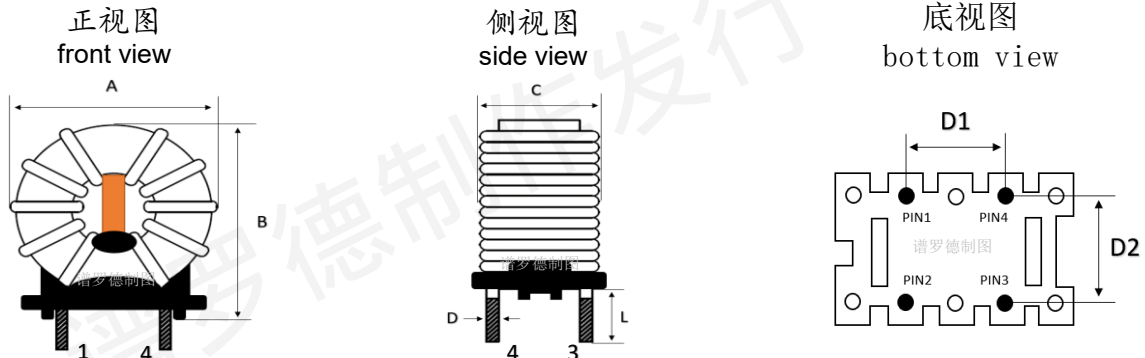

系列	封装尺寸 Dimension							MPQ
Series	A	B	C	D	D1	D2	L	吸塑盒/Tray
221413	28 Max	31 Max	18.5 Max	1.0±0.05	10.0±0.5	12.0±0.5	4.0 Min	96

电气参数

Electrical Characteristics

产品编码 P/N	@ 25 °C Ambient Temperature				
	感值 Inductance	精度 Tolerance	DCR	额定电流 rated current	耐压 HI-POT
	mH @1KHZ/0.3V	N1/N2 +/-	mΩ Max	A ΔT≈40°C	N1 vs N2 or N1/N2 vs Core AC/60Hz/1mA 3Sec
PDMCAT221413-102MLB	1	+∞/-20%	10	17	1.5KV
PDMCAT221413-202MLB	2	+∞/-20%	15	14	1.5KV
PDMCAT221413-502MLB	5	+∞/-20%	28	9.5	1.5KV
PDMCAT221413-103MLB	10	+∞/-20%	55	7	1.5KV
PDMCAT221413-203MLB	20	+∞/-20%	100	4.5	1.5KV
PDMCAT221413-303MLB	30	+∞/-20%	120	4	1.5KV

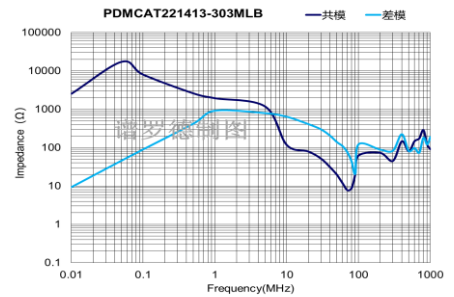
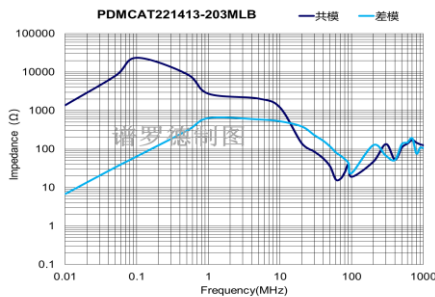
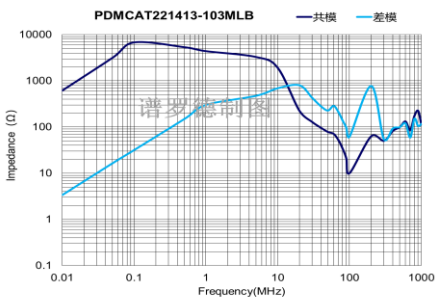
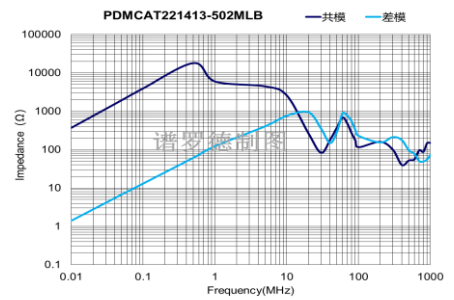
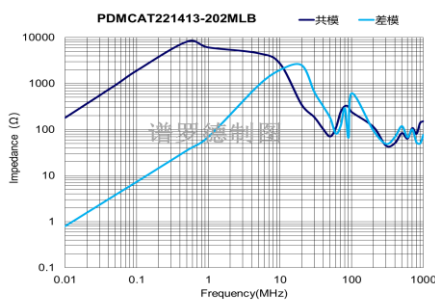
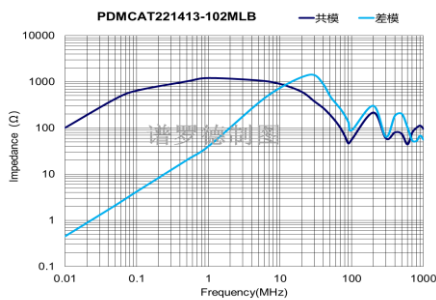

产品编码 P/N	PDMCAT2023-502MLB-6P	测试设备 TEST INSTRUMENT	Chroma: 3302 16502 Keysight: E4991
产品系列 Series	共模电感	测试频率 TEST FREQUENCY	1KHZ / 0.3V

封装尺寸 (mm)

Dimension

正视图
Front view

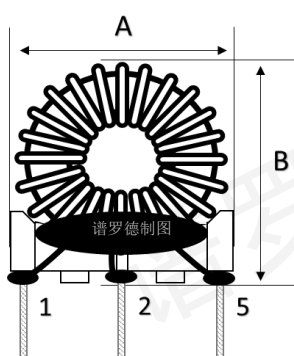

侧视图
Side view

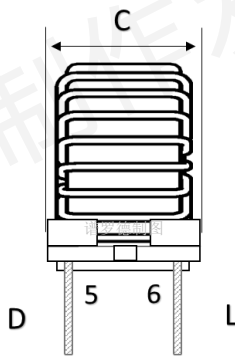

底视图
Bottom view

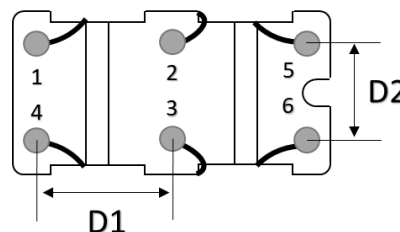

系列	封装尺寸 Dimension							最小包装/MPQ
Series	A	B	C	D	L	D1	D2	吸塑盒/Tray
2023	20.0 Max	23.0 Max	13.0 Max	1.0±0.1	3.0 Min	7.5 Typ	6.0 Typ	待定

编码解释

Code interpretation

PDMCAT	XXXX	-	XXX	M	L	B	-	6P
类别码	尺寸系列		感值	精度	立式	带底座		端子数量
Category code	Dimension		Inductance	Tolerance	Vertical type	Base		PIN Number

电气参数

Electrical Characteristics

产品编码 P/N	@ 25 °C Ambient Temperature				
	感值 Inductance	精度 Tolerance	DCR	额定电流 rated current	耐压 HI-POT
	mH @1KHZ/0.3V	N1/N2 +/-	mΩ Max	A ΔT≈40°C	N1 vs N2 or N1/N2 vs Core AC/60Hz1mA 3Sec
PDMCAT2023-502MLB-6P	5	+∞/-20%	35	4	600V

产品编码 P/N	PDMCAT-Series	测试设备 TEST INSTRUMENT	Chroma: 3302 16502 Keysight: E4991
产品系列 Series	共模电感	测试频率 TEST FREQUENCY	参考参数页面

封装尺寸 (mm)

Dimension

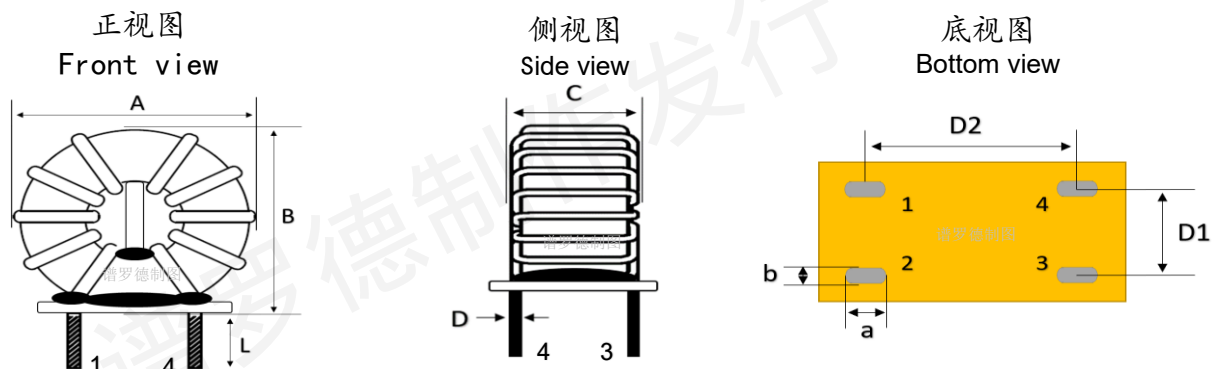

系列	封装尺寸 Dimension								最小包装/MPQ
Series	A	B	C	L	D1	D2	a	b	吸塑盒/Tray
251513	32.0 Max	28.0 Max	21.0 Max	6.0 Min	15.0±1	15.0±1	2.7 Ref	1.3 Ref	52

电气参数

Electrical Characteristics

产品编码 P/N	@ 25 °C Ambient Temperature				
	感值 Inductance	精度 Tolerance	DCR	额定电流 rated current	耐压 HI-POT
	N1/N2	N1/N2	mΩ	A	N1 vs N2 or N1/N2 vs Core
	mH	+/-	Max	$\Delta T \approx 40^\circ\text{C}$	AC/60Hz/1mA/3Sec
PDMCAT251513-102MLG	1	+∞/-20%	3.5	25	1KV

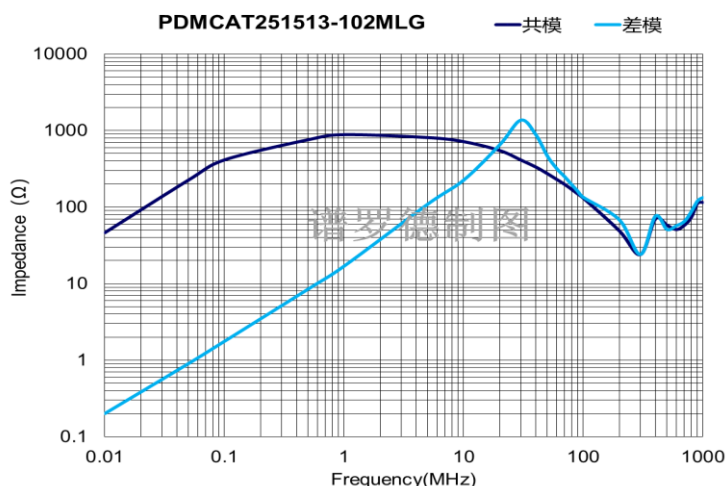

产品编码 P/N	PDMCAT-Series	测试设备 TEST INSTRUMENT	Chroma: 3302 16502 Keysight: E4991
产品系列 Series	共模电感	测试频率 TEST FREQUENCY	参考参数页面

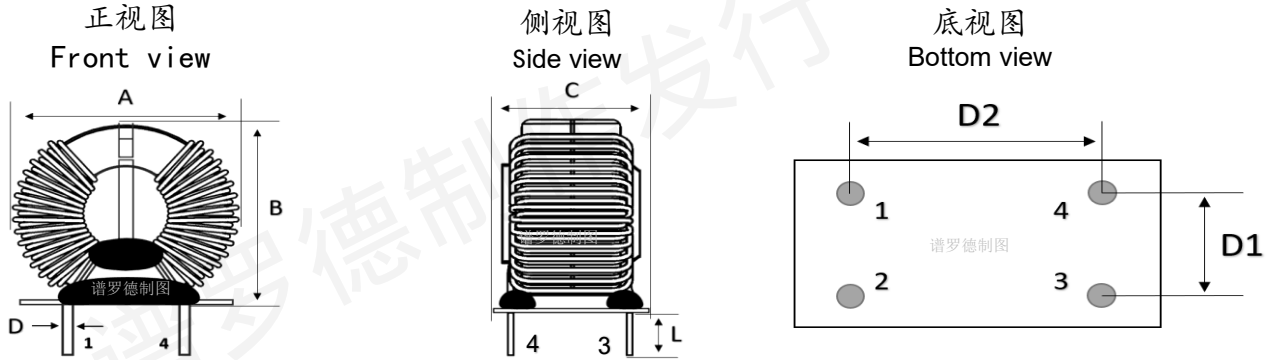
封装尺寸
Dimension (mm)

系列 Series	封装尺寸 Dimension							MPQ
	A	B	C	D	D1	D2	L	吸塑盒/Tray
353222	35 Max	32 Max	22 Max	见下列	15.5±1.0	18.0±1.0	3.0 Min	52

电气参数

Electrical Characteristics

产品编码 P/N	@ 25 °C Ambient Temperature						耐压 HI-POT N1~N2/N1&N2~C AC/60Hz1mA 3Sec 1.5KV
	感值 Inductance	精度 Tolerance	DCR	额定电流 rated current	D尺寸		
	mH	N1/N2	mΩ	A			
	@1KHZ/0.3V	±	Max	$\Delta T \approx 40^\circ C$			
PDMCAT353222A-202NLG	2	±30%	3	25	1.6±0.1		
PDMCAT353222A-502NLG	5	±30%	5	20	1.6±0.1		
PDMCAT353222A-103NLG	10	±30%	6	17	1.6±0.1		
PDMCAT353222A-203NLG	20	±30%	8.5	13	1.5±0.1		

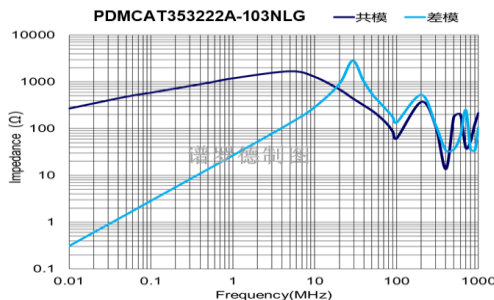
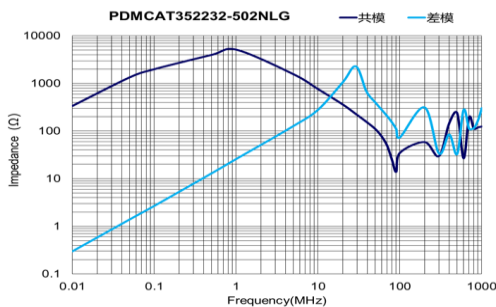
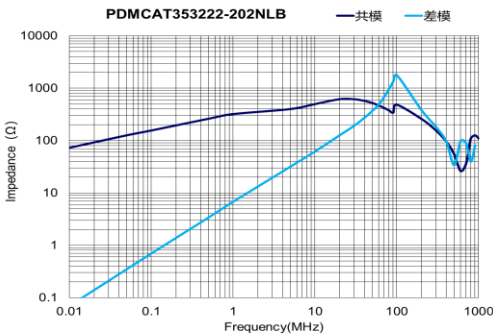

产品编码 P/N	PDMCAT-Series	测试设备 TEST INSTRUMENT	Chroma: 3302 16502
产品系列 Series	共模电感	测试频率 TEST FREQUENCY	参考参数页面

材料清单 Material List

NO.	材料 ITEM	材质规格 Material	制造商 Manufacturer
1	磁芯/Core	Mn-Zn/Ni-zn/Nanocrystalline magnetic core	YUFENG (Or use the same specifications from another manufacturer)
2	漆包线/Wire	F 155°C/F 180°C	PACIFIC (Or use the same specifications from another manufacturer)
3	隔板/Partition	Environmentally friendly epoxy resin	SUNSHINE (Or use the same specifications from another manufacturer)
4	底板/底座/	Environmentally friendly epoxy resin	YANGYU (Or use the same specifications from another manufacturer)
6	锡条/Sn	LEAD FREE SOLDER	CHENGNAN (Or use the same specifications from another manufacturer)
7	凡立水/Varnish	Environmentally friendly glue	TAL CHEMICAL (Or use the same specifications from another manufacturer)

*组件的材料不限制于清单内的制造商/The material of the part is not limited to the listed manufacturer

焊接温度（推荐）

Recommended Classification Wave Soldering Profile

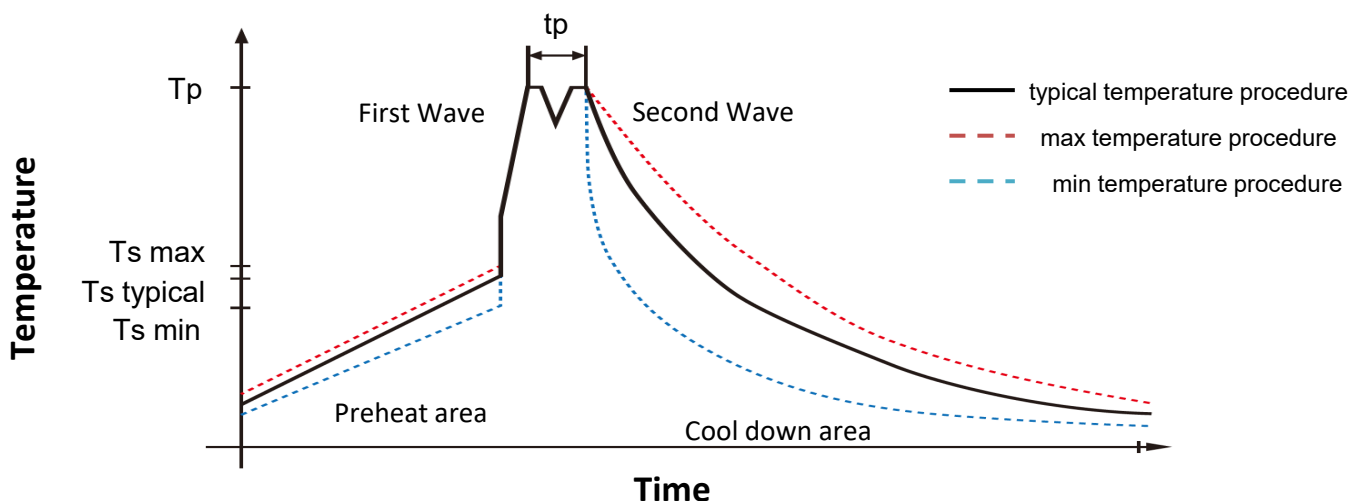

Profile Feature	Item	Pb-Free Assembly	Sn-Pb Assembly
Preheat Temperature Min	Ts min	100 °C	
Preheat Temperature Typical	Ts typical	120 °C	
Preheat Temperature Max	Ts max	130 °C	
Preheat Time ts from Ts min to Ts max	ts	70 seconds	
Ramp-up Rate	ΔT	150 °C max.	
Peak Temperature	Tp	250 °C - 260 °C	235 °C - 260 °C
Time of actual peak temperature	tp	max. 10 seconds max. 5 seconds each wave	
Ramp-down Rate, Min		~ 2 K/ second	
Ramp-down Rate, Typical		~ 3.5 K/ second	
Ramp-down Rate, Max		~ 5 K/ second	
Time 25 °C to 25 °C		4 minutes	

* 参考标准: EN61760-1:2006 refer standard to: EN61760-1:2006





注意事项

使用本产品时，请注意以下事项

- ◎ 产品保存期限为12个月，保存条件：温度5~40℃，湿度10~75%RH以内，超过保存期限可能会使元器件电极发生氧化，存储标准可参照：IEC_61760-2-2021
This components storage life is 12 months, Storage Temperature: TEMP.5~40℃; RH10%~75%. Please use this components within the warranty period. refer standard to: IEC_61760-2-2021
- ◎ 请勿在极端环境下使用和保存（高盐，强酸，强碱，强辐射等）。
Do not use this component in special environments, such as high salt content, strong acid, strong alkali, strong corrosion and other special environments.
- ◎ 元器件焊接前，请进行预热，预热与焊接温度之间温差建议控制在150℃以内；焊接标准参考：EN61760-1:2006
Please preheat the product before welding; it is recommended to control the preheating temperature and welding temperature within 150℃. refer standard to: EN61760-1:2006
- ◎ 元器件焊接后需重新拆卸焊接修正时，请遵循规格书规定的条件范围；过高的加热温度以及反复的拆卸可能会导致元器件失效。
When repairing this component, the temperature used for disassembly should not exceed the datasheet limit and do not disassemble it frequently to prevent damage to the component.
- ◎ 请勿用清洗剂、丙酮等腐蚀性液体接触该元器件，这可能会侵蚀元器件本体以至于失效。
Do not use acetone or other corrosive liquids to contact this component or it will cause it to fail.
- ◎ 元器件焊接到线路板后，请注意不可因线路板整体变形或局部变形而施加给电感剩余应力，这可能会导致元器件脱落、破损失效。
When this component is soldered to the circuit board, you need to pay attention to the stress applied to it by the PCB, which may cause it to fall off or damaged fail.
- ◎ 元器件通电后温度会随电流的增大而上升，设计时请务必考虑留有余量。
Self heating (Rated Current or Irms) occurs when the power is turned ON, so the tolerance should be sufficient for the set thermal design.
- ◎ 过高的静电会损坏该元器件，请注意静电防护。
Too high static electricity will cause permanent damage to the product, please pay attention to electrostatic protection.
- ◎ 本元器件作为磁性产品，设计时请务必考虑周边元器件与本产品可能产生的耦合效应影响。
This magnetic component needs to be considered for coupling effects in the application.
- ◎ 谱罗德并不能完全掌握或熟悉客户的特定应用以及要求，贵司有责任和义务验证此元器件以及元器件规格书中的描述是否满足于贵司的设计要求；需要指出是：即使按照现有的技术标准操作，该元器件依然有几率在典型寿命结束前发生故障，谱罗德强烈建议贵司对于该元器件在一些典型的严苛应用中，例如安规产品，工业产品、医疗产品、车载产品、航空/航天等产品应用，对于该元器件可能存在的失效情况做适当的冗余设计，以此避免该元器件在失效时造成严重后果；特别提醒：对于特定的应用对象谱罗德强烈要求贵司同谱罗德取得书面的许可，否则谱罗德不予承担元器件失效带来的任何责任，特定对象包括且不限于：车用，航空航天，安规产品，军用以及贵司对元器件有严苛要求的产品。
PROD cannot fully understand and be familiar with customers' specific applications and requirements. Your company has the responsibility and obligation to verify whether the components and the description in the component specification meet your design requirements. Special reminder: Even if operated in accordance with existing technical standards, this component still has a chance of failure before the end of its typical life. PROD strongly recommends that your company make appropriate redundant designs for possible failure situations of this component in some typical harsh applications, such as safety products, industrial products, medical products, automotive products, aviation/aerospace products, etc., so as to avoid serious consequences when the component fails.
PROD Requirements: For specific application item, PROD strongly requires your (or company) to obtain written permission from PROD, otherwise PROD will not bear any responsibility for component failure. Specific item list include but are not limited to: automotive, aerospace, safety products, military and products that your company has strict requirements on components.



谱罗德电子科技（深圳）有限公司
PuLuoDe Electronic Technology (Shenzhen) Co., LTD
深圳市宝安区石岩三联工业区B栋311

更多规格请访问谱罗德官方网站
下载或者扫描二维码通过微信小程序获取

<http://www.prodtech.cn/>

