



钜地半导体
Tudi Semiconductor

Product Specification

TUDI-SP3220

+3.0V to +5.5V RS-232 Driver/Receiver Pair

网址 www.sztdbdt.com Q

用芯智造 · 卓越品质

semiconductor device
manufacturer

- Design
- research and development
- production
- and sales



Features

- Meets all EIA/TIA-232-F Standards from a +3.0V to +3.6V power supply (5V (Customized Required))
 - Interoperable with RS-232 and V.28 at +2.7V
- Supports High Serial Data Rates:
 - 120kbps SP3220E
 - 250kbps SP3220EB
 - 1Mbps SP3220EU
- 1 μ A Low Power Shutdown Mode
- 4 x 1.0 μ F External Charge Pump Capacitors
- Improved ESD Specifications:
 - +15kV Human Body Model
 - +15kV IEC61000-4-2 Air Discharge
 - +8kV IEC61000-4-2 Contact Discharge

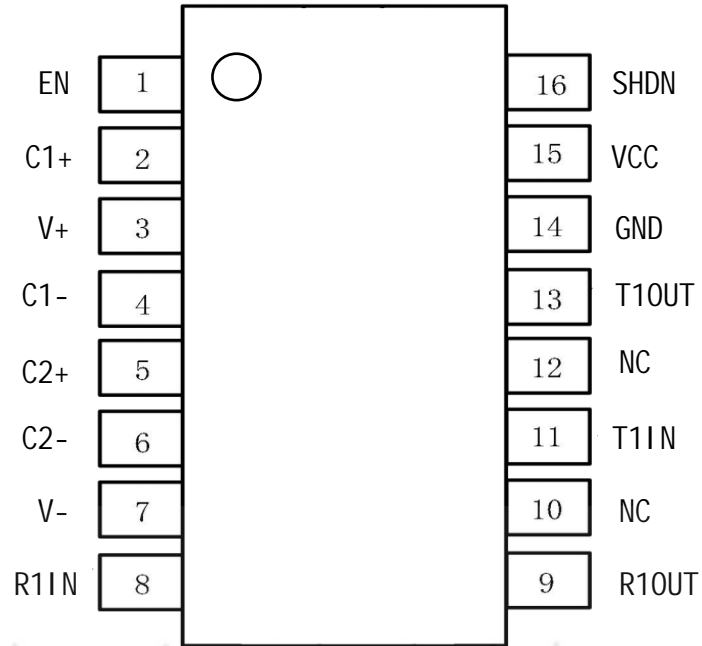

Description

The SP3220E devices are RS-232 driver/receiver solutions intended for portable or hand-held applications such as palmtop computers, instrumentation and consumer products. These devices incorporate a high-efficiency, charge-pump power supply that allows the SP3220E devices to deliver true RS-232 performance from a single power supply ranging from +3.0V to +5.0V. (5V (Customized Required)) This charge pump requires only 0.1 μ F capacitors in 3.3V operation. The ESD tolerance of the these devices are over +/-15kV for both Human Body Model and IEC61000-4-2 Air discharge test methods. All devices have a low-power shutdown mode where the driver outputs and charge pumps are disabled. During shutdown, the supply current falls to less than 1 μ A.

Applications

- Battery-powered equipment and handheld devices
- Notebook and handheld computer
- Cell phone data cable
- Terminal Adapter and POS Terminal
- modem



Pin description

Pin Number	Name	Function
1	EN	Receiver Enable. Apply Logic LOW for normal operation. Apply logic HIGH to disable the receiver outputs (high-Z state)
2	C1+	Positive terminal of the voltage doubler charge-pump capacitor
3	V+	+5.5V output generated by the charge pump
4	C1-	Negative terminal of the voltage doubler charge-pump capacitor
5	C2+	Positive terminal of the inverting charge-pump capacitor
6	C2-	Negative terminal of the inverting charge-pump capacitor
7	V-	-5.5V output generated by the charge pump
8	R1IN	RS-232 receiver input
9	R1OUT	TTL/CMOS receiver output
10	NC	No Connect
11	T1IN	TTL/CMOS driver input
12	NC	No Connect
13	T1OUT	RS-232 driver output.
14	GND	Ground
15	Vcc	+3.0V to 3.6V supply voltage (5V (Customized Required))
16	SHDN	Shutdown Control Input. Drive HIGH for normal device operation Drive LOW to shutdown the drivers (high-Z output) and the onboard power supply



Absolute maximum rating

Characteristic	Symbol	Minimum limit	Representative value	Maximum limit	Unit
Maximum operating voltage	V _{CC}			+7	V
Positive charge pump	V ₊	-0.3		+7	V
Negative charge pump	V ₋	-7		+0.3	V
Drive input pin	T1IN	-0.3		+7	V
Receiver input pin	R1IN	-20		+20	V
Drive output pin	T1OUT	-15		+15	V
Receiver output pin	R1OUT	-0.3		V _{CC} +0.3	
Storage temperature	T _{STG}	-65		+150	°C
Maximum junction temperature	T _J			+150	°C
ESD-HBM	ESD-HBM	2000			V

Note : Exceeding any of the above limits in working conditions may result in permanent damage to the device.

Recommended Operating Conditions

Characteristic	Symbol	Minimum limit	Representative value	Maximum limit	Unit
Recommended operating voltage	V _{DD}	3	3.3	3.6	V
Working temperature	T _A	-40		+85	°C

Note : Operating outside the recommended operating temperature range may degrade the device performance

Warning: This product is an electrostatic sensitive device. Anti-static measures must be implemented throughout its storage, transportation, and use.



Electrical characteristics

Unless otherwise noted, the following specifications apply for $V_{CC} = +3.0V$ to $+3.6V$ with $T_{AMB} = T_{MIN}$ to T_{MAX} , Typical values apply at $V_{CC} = +3.3V$ or $+3.6V$ and $T_{AMB} = 25^{\circ}C$.

Parameter	Condition	Minimum	Typical case	Maximum	Unit
Drive input	T1IN				
Drive output	R1OUT				
RS-232 input	R1IN				
RS-232 output	T1OUT				
Charge pump	C1+,C1-,C2+,C2-				
Power pin	Vcc,VGND,V+,V-				
Charge pump capacitor	C1+,C1-,C2+,C2-	0.1	0.1	1	uF
Temperature	Commercial Grade	-40	25	85	°C
Supply voltage	Vcc=+3.3V	3	3.3	3.6	V
Working current	TTL Inputs =Vcc/GND,RS-232 Input = float,		0.5	1	mA
Current when SHUTDOWN is enabled	SHDN=GND		1	10	uA
Drive input					
Input threshold voltage Low	Vcc=+3.3V Supply VIn=Vcc and GND,TIN			0.8	V
Input threshold voltage High		2.4			V
Input threshold voltage hysteresis			0.5		V
Input leakage current			±0.1	±1	uA
Receiver output					
Output voltage Low	IouT=1.6mA			0.4	V
High output voltage	IouT=-1.0mA	VCC-0.6	VCC-0.1		V
Output leakage current	Receiver Outputs Disabled, VouT=Vcc or GND,		±0.1	±10	uA
Receiver input					
Input voltage swing	TA=25°C,Vcc=3.3V Supply	-20		20	V
Input threshold voltage Low		0.8			V
Input threshold voltage High				2.4	V
Input threshold voltage hysteresis			0.5		V
Input resistance		VIn=±20V,TA=25°C	3	5	7
Drive output					
Output voltage amplitude	RL=3kΩ,All Outputs are loaded	±5			V
Output resistance	Vcc=V-=Vn=GND,VouT =±2V	300			Ω
Output short circuit current	VouT =GND			±60	mA
Output leakage current	Transmitter Disabled,VouT =±12V		±5		uA
Switching characteristic					
Maximum data transfer rate	RL =3kΩ,CL =1000pF,One Transmitter Switching,TA=25°C	120-1000			Kbps



Electrical characteristics (Continued)

Unless otherwise noted, the following specifications apply for $V_{CC} = +3.0V$ to $+3.6V$ with $T_{AMB} = T_{MIN}$ to T_{MAX} , Typical values apply at $V_{CC} = +3.3V$ or $+3.6V$ and $T_{AMB} = 25^{\circ}C$.

Parameter	Condition	Minimum	Typical case	Maximum	Unit
Transmission swing limit	$R_L = 3 \sim 7k\Omega, C_L = 150pF$ to $1000pF$, One Transmitter Switching, $T_A = 25^{\circ}C$, Measured from $3V$ to $-3V$ or $-3V$ to $3V$	6		30	V/uS
Receiver input delay	$C_L = 150pF$		0.15		μS
Receiver output delay			0.15		μS
Receiver input output delay difference			50		nS
ESD protection capability					
ESD HBM	RS-232 Inputs and Outputs		± 15		KV
EN61000-4-2ContactDis charge			± 8		KV
EN61000-4-2AirGapDischarge			± 15		KV

Test Circuit Diagram

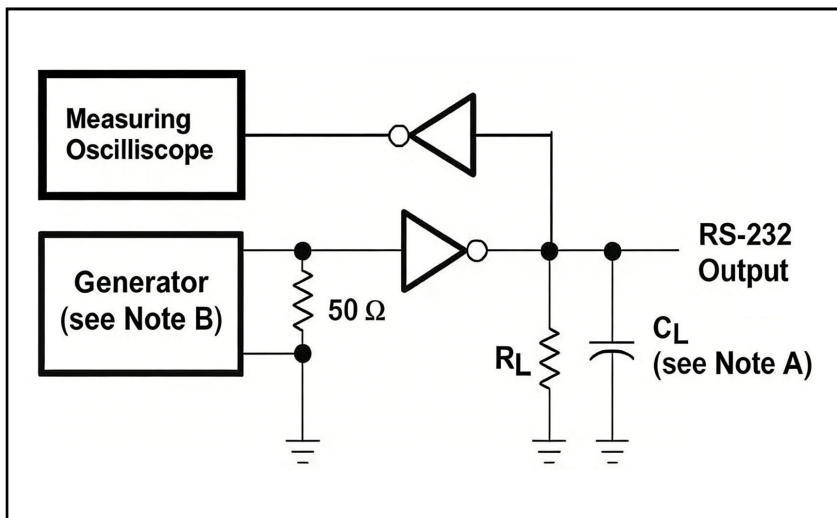

Note:

A. $R_L = 3\ k\Omega, C_L = 1000\ pF, T_A = 25^{\circ}C$, one driver operating.

B. The waveform generator shall meet the following specifications:

PRR = 250 kbps, $Z_o = 50\ \Omega$, 50% duty cycle, T_r & $T_f \leq 10\ ns$.

C. SHDN = V_{CC}

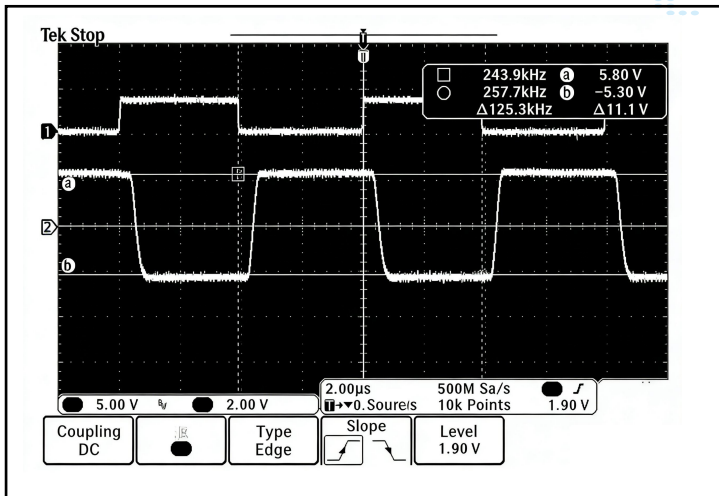

Figure 1. SP3220 TIN to TOUT (no Load) at 250kbps Waveform

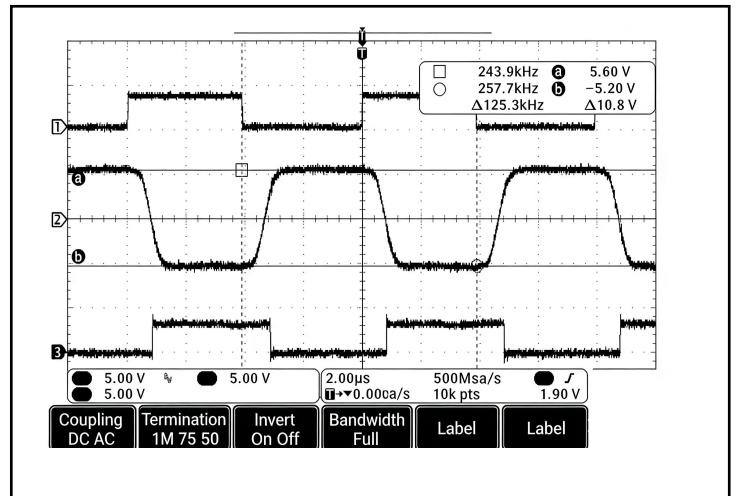

Figure 2. SP3220 TIN to TOUT to ROUT (loopback to Rx With 1000pF Load) at 250kbps Waveform

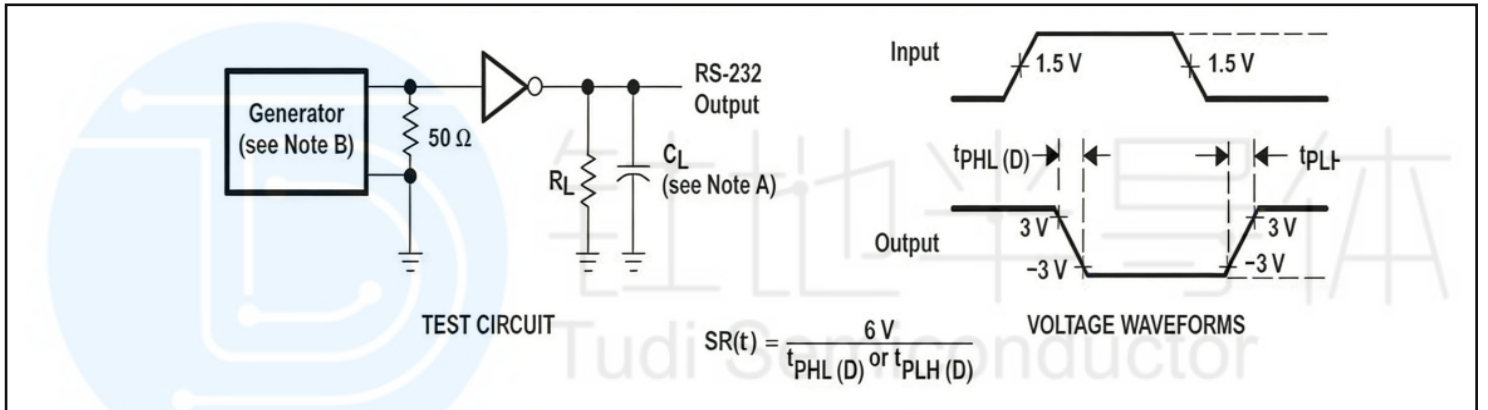

Figure 3. Driver Transition-Region Slew Rate Test Circuit

Notes:

- A. $R_L = 3k\sim 7k\Omega$, $C_L = 150pF$ to $1000pF$,
One Driver Switching, $T_A = 25^\circ C$,
Measured from $+3V$ to $-3V$ or $-3V$ to $+3V$.
- B. The pulse generator had the following characteristics:
PRR = 250 kbps, $Z_o = 50\Omega$, 50% duty cycle, T_r & $T_f < 10ns$

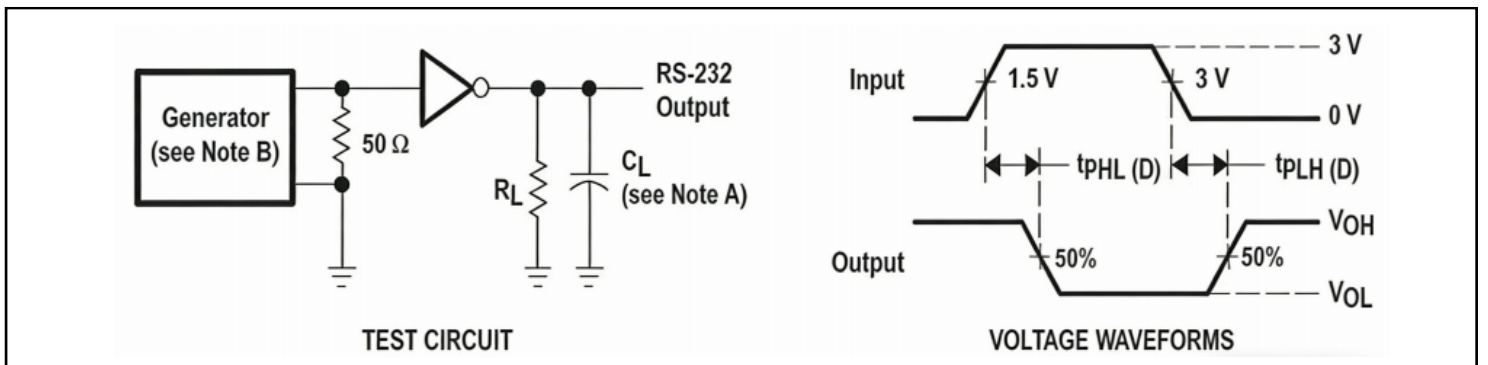

Figure 4. Driver Propagation (t_{PHL} & t_{PLH}) Test Circuit



Notes:

A. All drivers loaded with $R_L = 3k\ \Omega$, $C_L = 1000pF$.

B. The pulse generator had the following characteristics:

PRR = 250 kbps, $Z_o = 50\ \Omega$, 50% duty cycle,

T_r & $T_f < 10ns$.

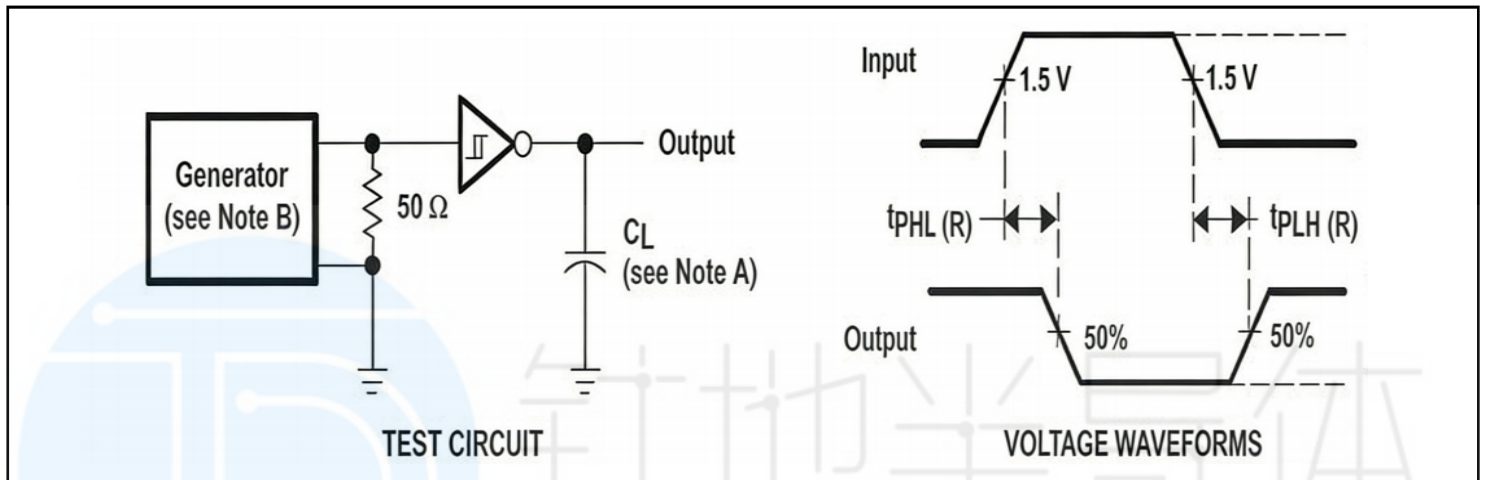

Figure 5.Receiver Propagation Delay Times Test Circuit

Notes:

A. $C_L = 150pF$, including probe and jig capacitance.

B. The pulse generator had the following characteristics:

PRR = 250 kbps, $Z_o = 50\ \Omega$, 50% duty cycle,

T_r & $T_f < 10ns$.

Truth Table

Operative mode	SHDN	EN	T1OUT	R1OUT
Shutdown	00	01	tri-state tri-state	active tri-state
Normal	11	00	active active	active tri-state



Peripheral Reference Circuit:

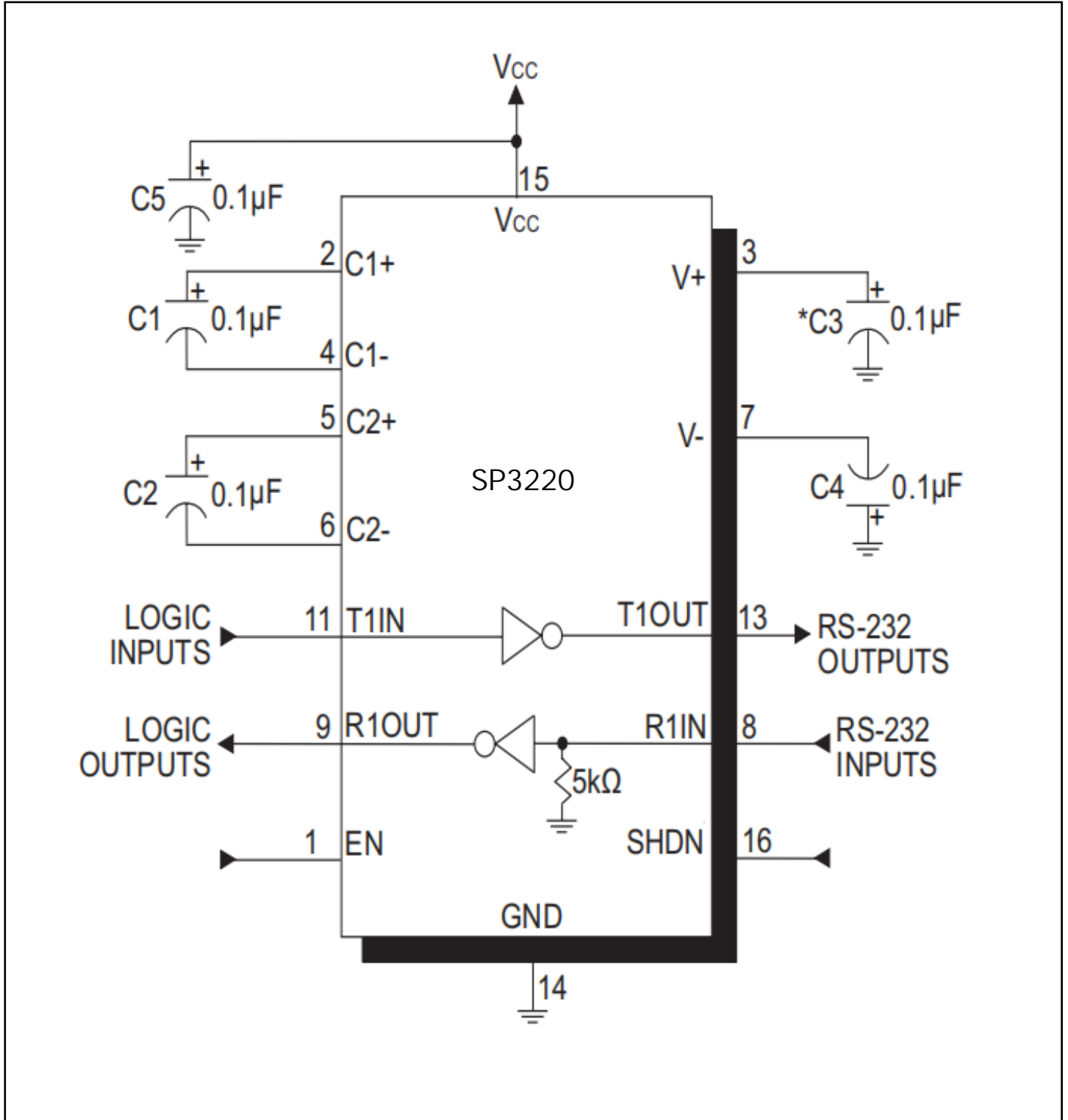



Additional description

RS-232 Signal Characteristics

Figure 1 shows the function of an RS-232 transceiver. A TTL/CMOS signal is applied to the driver input (e.g., Channel 1), and the corresponding RS-232 driver output is displayed on Channel 2. This figure depicts a typical unloaded RS-232 driver output, which represents an open-circuit output voltage of RS-232. The charge pump voltage converter efficiently generates the voltage required for the driver output, bringing the RS-232 output close to the ideal voltage of 5.8 V.

Figure 2 shows the function of the RS-232 transceiver. A TTL/CMOS signal is applied to the driver input, e.g., Channel 1, and the RS-232 driver output is shown on Channel 2. The RS-232 signal is illustrated with an output load of 3 k Ω and 1000 pF. The resistive load corresponds to the input impedance of the receiver when the driver output is connected to the receiver input. Channel 3 shows the TTL/CMOS output of the receiver. Under a typical RS-232 load and at a data rate of 250 kbps, the driver output voltage drops by only 0.2 V compared with its open-circuit voltage. The RS-232 driver output on Channel 2 exhibits good signal integrity at high speed, allowing the receiver to minimize slope and delay when processing signals. The low-dropout driver circuit of the SP3220, together with its high-efficiency regulator, provides excellent line-driving capability and ± 15 kV ESD protection.

Dedicated Switched-Capacitor Voltage Converter

It adopts a specially protected two-channel switched-capacitor voltage controller design to provide robust bipolar voltages, ensuring that outputs meet the EIA/RS-232 standard even under supply voltage fluctuations. The design consists of an internal regulated oscillator, two-phase clock cycle, regulated MOS switches, fast-switching diodes, and switched capacitors.

The switched-capacitor bidirectional current generators utilize proprietary complementary MOS switches and intelligent regulation with fast-switching diodes, based on a proprietary high-voltage process technology. The efficiency of these bidirectional current generators well exceeds 70%. The switching frequency is generated by an internal oscillator and adjusted according to the current load.

The switched-capacitor pump design delivers a negative buck voltage higher than the positive boost voltage. Load regulation via the current generators enables balanced voltage control, providing a well-balanced bipolar voltage supply for the chip.

The interface product family employs unique proprietary design techniques to deliver higher energy efficiency, greater stability, and low-power products compliant with the EIA/RS-232 standard.

ESD protection circuit

Electrostatic discharge (ESD) is an important parameter in serial port applications of systems. In certain applications, it is critical that the system's ESD protection capability provides sufficient margin. Since RS-232 transceiver devices are exposed externally, many environmental factors can affect the serial port and subject it to transients that may damage the transceiver itself.

RS-232 transceivers are typically routed from the serial port connector to the transceiver IC via metal traces on a printed circuit board. These traces have a small resistance, which limits the transient current reaching the IC and thus provides some protection. However, additional voltage protection devices such as transient voltage suppressors (TVS) or transzorbs, which are back-to-back diode array clamps, are usually required to protect the serial port circuitry.

To further reduce system cost, more internally integrated protection circuits are needed without adding expensive external TVS components. Tudi's RS-232 transceivers feature built-in transient voltage suppression circuitry and meet MIL-STD-883, Human Body Model (HBM), and EN61000-4-2 air / contact discharge testing



without external ESD circuits.

The Human Body Model has become an accepted ESD test method for semiconductors. It simulates the process in which the human body stores electrostatic energy and discharges it to an integrated circuit upon approach or contact. This method tests the IC ' s ability to withstand ESD transients during normal handling, such as in manufacturing environments where ICs are frequently touched.

EN61000-4-2 is used to test ESD performance on equipment and systems. For system manufacturers, it is essential to ensure a defined level of ESD protection because the system is exposed to the external environment and human contact. EN61000-4-2 specifies that a system must withstand a certain level of electrostatic discharge when ESD is applied to exposed metallic points or to surfaces touched by personnel during normal operation.

When ESD is applied to connector pins, the transceiver IC will carry most of the ESD current. EN61000-4-2 defines two methods: air discharge and contact discharge. Air discharge applies ESD voltage to the device under test through the air. It simulates a charged person approaching a system to connect a cable, and before physical contact, the high electrostatic potential discharges via an arc to the rear panel of the system. Contact discharge applies ESD current directly to the EUT. This method is intended to reduce the unpredictability of ESD arcing. Compared with air-gap arcing, the discharge current rise time is more consistent with direct energy transfer.

Tudi ' s RS-232 transceivers meet and exceed the minimum requirements of EN61000-4-2, with $\pm 15\text{kV}$ for air discharge and $\pm 8\text{kV}$ for contact discharge.

Order information

Order Number	Package	Package Quantity	Marking On The park	Temperature	Operating Voltage
SP3220ECA-L/TR-TUDI	SSOP16	Tape,Reel,2000	SP3220ECA	0°C to 70°C	3.0V-3.6V 5V (Customized Required)
SP3220ECY-L/TR-TUDI	TSSOP16	Tape,Reel,2500	3220EC	0°C to 70°C	
SP3220EEA-L/TR-TUDI	SSOP16	Tape,Reel,2000	SP3220EEA	-40°C to 85°C	
SP3220EEY-L/TR-TUDI	TSSOP16	Tape,Reel,2500	3220EE	-40°C to 85°C	
SP3220EBCA-L/TR-TUDI	SSOP16	Tape,Reel,2000	SP3220EBCA	0°C to 70°C	
SP3220EBCY-L/TR-TUDI	TSSOP16	Tape,Reel,2500	3220EBC	0°C to 70°C	
SP3220EBEA-L/TR-TUDI	SSOP16	Tape,Reel,2000	SP3220EBEA	-40°C to 85°C	
SP3220EBEY-L/TR-TUDI	TSSOP16	Tape,Reel,2500	3220EBE	-40°C to 85°C	
SP3220EUEY-L/TR-TUDI	TSSOP16	Tape,Reel,2500	3220EUE	-40°C to 85°C	



Package TSSOP16

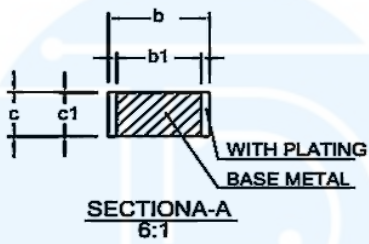
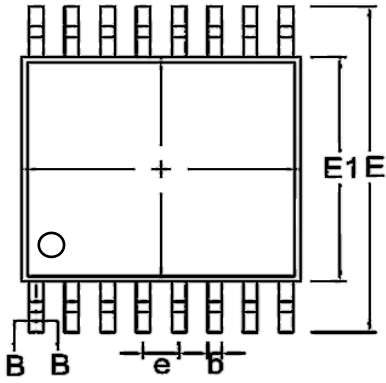

SIZE SYMBOL	MIN./mm	TYP./mm	MAX./mm
A	--	--	1.20
A1	0.05		0.15
A2	0.90	1.00	1.05
b	0.20	--	0.30
b1	0.19	0.22	0.25
C	0.110	0.127	0.145
cl	0.12	0.13	0.14
D	4.86	4.96	5.06
E	6.20	6.40	6.60
E1	4.30	4.40	4.50
e	0.65BSC		
L	0.45	0.60	0.75
L1	1.00BSC		
	0°	--	8°

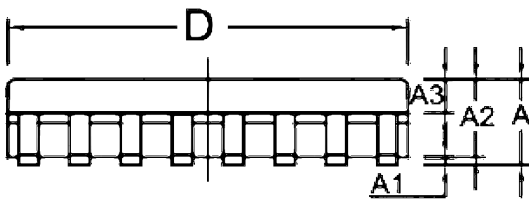



Package SSOP16

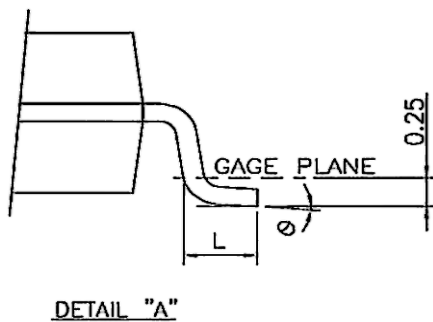
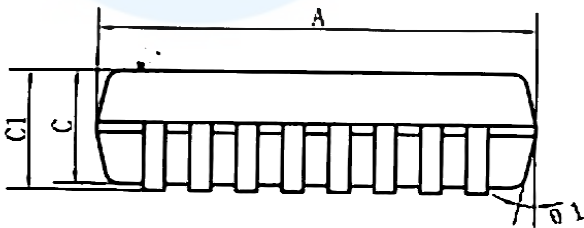
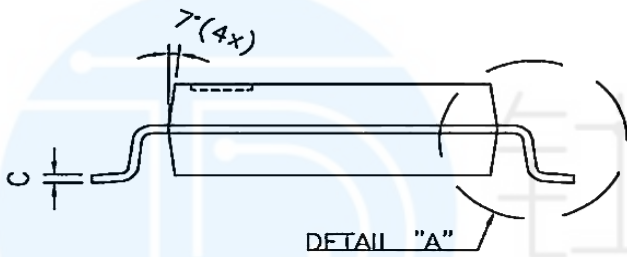
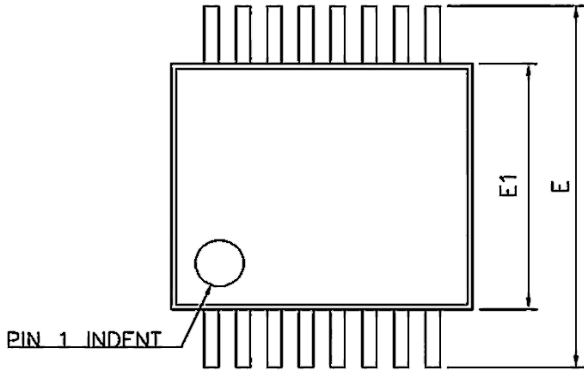

SIZE SYMBOL	MIN/mm	MAX/mm
A	6.15	6.25
A1	0.30TYP	
A2	0.65TYP	
A3	0.675TYP	
B	5.25	5.35
B1	7.65	7.95
B2	0.60	0.80
C	1.70	1.80
C1	1.75	1.95
C2	0.799	
C3	0.152	
C4	0.172	
H	0.05	0.15
θ	12°TYP4	
O1	12°TYP4	
O2	10°TYP	
O3	0°~8°	
R	0.20°TYP	
R	0.15°TYP	



Important statement:

- TUDI Semiconductor reserves the right to modify the product manual without prior notice! Before placing an order, customers need to confirm whether the obtained information is the latest version and verify the completeness of the relevant information.
- Any semi-guide product is subject to failure or malfunction under specified conditions. It is the buyer's responsibility to comply with safety standards when using TUDI Semiconductor products for system design and whole machine manufacturing. And take the appropriate safety measures to avoid the potential in the risk of loss of personal injury or loss of property situation!
- TUDI Semiconductor products have not been licensed for life support, military, and aerospace applications, and therefore TUDI Semiconductor is not responsible for any consequences arising from the use of this product in these areas.
- If any or all TUDI Semiconductor products (including technical data, services) described or contained in this document are subject to any applicable local export control laws and regulations, they may not be exported without an export license from the relevant authorities in accordance with such laws.
- The specifications of any and all TUDI Semiconductor products described or contained in this document specify the performance, characteristics, and functionality of said products in their standalone state, but do not guarantee the performance, characteristics, and functionality of said products installed in Customer's products or equipment. In order to verify symptoms and conditions that cannot be evaluated in a standalone device, the Customer should ultimately evaluate and test the device installed in the Customer's product device.
- TUDI Semiconductor documentation is only allowed to be copied without any alteration of the content and with the relevant authorization. TUDI Semiconductor assumes no responsibility or liability for altered documents.
- TUDI Semiconductor is committed to becoming the preferred semiconductor brand for customers, and TUDI Semiconductor will strive to provide customers with better performance and better quality products.