	SPECIFICATION	PRODUCT	LINEAR VIBRATOR
		MODEL	LD0625BC
		REVISION NO.	REV.00

立得微电子（惠州）有限公司

Leader Micro Electronics (Huizhou) Co., Ltd

产品规格书

PRODUCT SPECIFICATION

客户信息 Customer Information	客户名称/Customer	
	客户料号/Part No.	
	客户承认签/Customer Apprroved Signatures	

产品信息 Product Information	文件编号/Spec No.	LD0625BC-0349F	
	品名/Description	线性振动马达 Linear Vibrator Motor	
	规格型号/Model	Φ 6x2.55T,260Hz,0.7Vrms AC	
	日期/Date	2025.09.10	
	编制/Designed	审核/checked	批准/Approved
	李月婷	晋峰	王远东



地址: 中国广东省惠州市小金口老虎岭工业园

Add: Leader Micro Electronics (huizhou) Co., ltd

Tiger Industrial Park,XiaojinKou,Huizhou,Guangdong,China

电话/Tel:+86-752-5853255 传真/Fax:+86-752-5839222



网址/Http: //www.leader-cn.cn 邮箱/E-mail: leader@leader-cn.cn 邮编/postcode: 516000

 	SPECIFICATION	PRODUCT	LINEAR VIBRATOR
		MODEL	LD0625BC
		REVISION NO.	REV.00

规格书目录

Specification Content

No.	规格书内容/Specification contents	页码/Page
0	修订履历/Modification Records	3
1	适用范围/General	4
2	使用条件/Operating Condition	4
3	测定条件/Determination Conditions	4
4	性能标准/ characteristics Standard	5
5	机械性能/Mechanical characteristics	6/7
6	测定方法/ Determination Condition	8
7	可靠性实验/Reliability Test	9/10
8	判断特性/Requirements after reliable test	10
9	使用注意事项/Points for Attentions	11
10	包装/Packing	12
11	马达外形图/Motor outline drawing	13

 	SPECIFICATION	PRODUCT	LINEAR VIBRATOR
		MODEL	LD0625BC
		REVISION NO.	REV.00

1、适用范围/General

本规格书适用于线性振动马达 LD0625BC 系列。

This specification applies to linear type motor LD0625BC series.



2、使用条件/Operating conditions

项目/Item		规格/Specification
2-1	额定电压/Rated Voltage	0.7±0.05 Vrms AC, Sinewave
2-2	使用电压范围/Operating Voltage	0.1 ~ 0.75 Vrms AC
2-3	输入频率/Input Frequency	260±10Hz
2-4	振动方向/Direction of vibration	Z axis
2-5	使用环境/Operating Environment	-20℃~+60℃, Ordinary Humidity:65±20%RH
2-6	保存条件/Storage Conditions	-30℃~+70℃, No condensation of moisture

3、测定条件/Determination Conditions



一般情况下，马达可以在 22~28℃，相对湿度 45~85%RH 的环境中测试.为保证一致性，测试应在下表规定内进行 Normally, the motor could be tested under 22~28℃,45~85%RH. To ensure the coherence, it must be tested under below environment requirements:

项目/Item		规格/Specification
3-1	温度/Temperature	25℃±3℃
3-2	湿度/Humidity	65±20%RH
3-3	气压/Air Pressure	1011±40 hpa

 	SPECIFICATION	PRODUCT	LINEAR VIBRATOR
		MODEL	LD0625BC
		REVISION NO.	REV.00



4、性能标准/ characteristics Standard

项目/Item		规格/Specification	测试条件/Test Condition
4-1	额定电压 Rated Voltage	0.7VrmsAC, Sine wave	0.7VrmsAC, Sine wave
4-2	额定电流 Rated Current	90mArms Max	Input source : F0, 0.7Vrms AC, sine wave (60g JIG)
4-3	F0 点振动量 Acceleration	0.65Grms Min	
4-4	频率特性 Frequency Characteristics	260±10Hz Refer to Figure 1	
4-5	上升时间 Rise Time	Max 50msec From 0 to 50% of nominal vibration 	Input source : F0, 0.7Vrms AC, sine wave
4-6	下降时间 Falling Time	Max 80msec From 100% to 50% of nominal vibration 	Input source : F0, 0.7Vrms AC, sine wave
4-7	绝缘电阻 Insulation Resistance	10MΩ Min (100V)	在 100V 直流电压下机壳与导线/At DC 100V Between wire and case
4-8	阻抗 Resistance	8±2 Ω	在 25℃ 下/Below 25℃

 	SPECIFICATION	PRODUCT	LINEAR VIBRATOR
		MODEL	LD0625BC
		REVISION NO.	REV.00

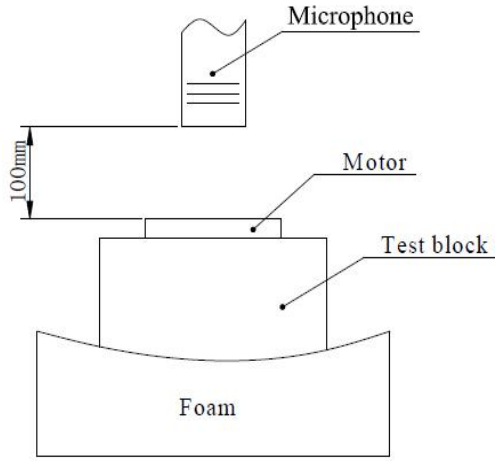
5、机械性能/Mechanical characteristics



项目/Item		规格/Specification	测试条件/Test Conditions
5-1	噪音/Noise	50分贝最大/50dB Max. (10cm distance from microphone/ 距离麦克风 10 cm 的位置)	<p>Input source : F0, 0.7VrmsAC,sinewave ,260Hz 在额定电压下。At rated voltage 背景噪音：不大于28dB.A计权 Back ground noise 28dB(A) Max</p> 
5-2	机械噪音 mechanical noise	35 dB Max	<p>对于项目 5-1 的噪音，我们可以使用另一种测量设备，量产时进行整批检查。 For the noise of project 5-1, we can use another measuring device to conduct a batch inspection during mass production</p> <p>测量设备型号:Bako 2120C Measurement equipment model</p> <p>测试原理/Testing principle: 如果有内部部件接触或摩擦产生的机械噪声 可通过传感器判定异常噪音的来源 If there is mechanical noise generated by internal component contact or friction The source of abnormal noise can be determined through sensors</p>
5-3	马达尺寸 Size of motor	Φ6*2.55mm	slide calipers

		SPECIFICATION	PRODUCT	LINEAR VIBRATOR
			MODEL	LD0625BC
			REVISION NO.	REV.00

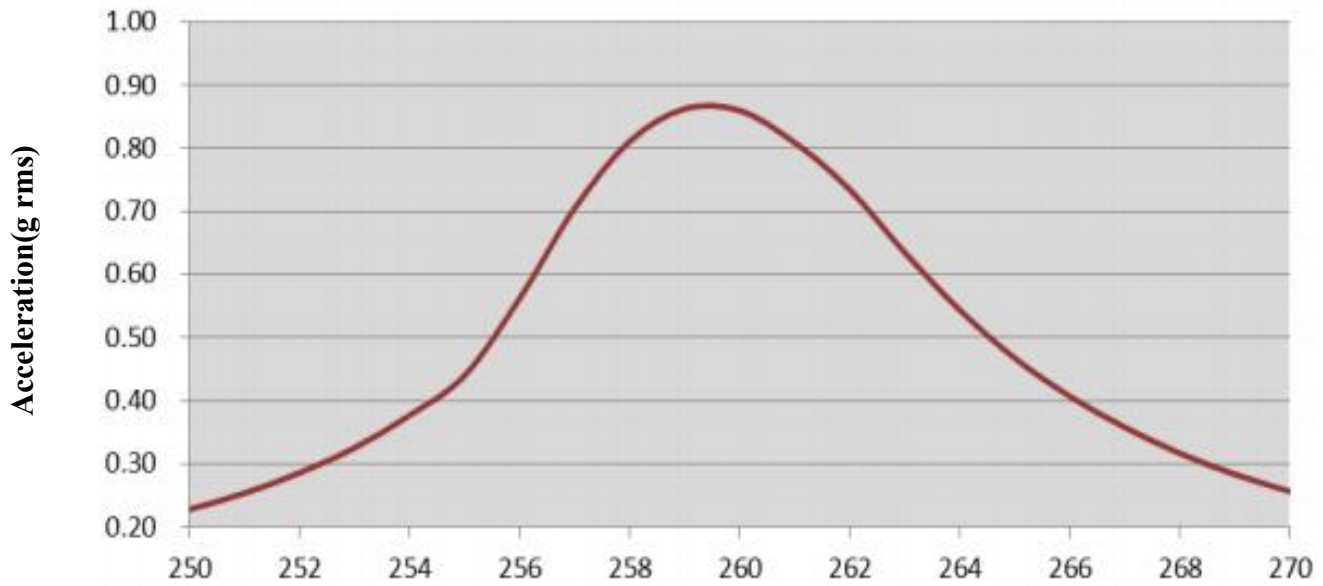
Acceleration Characteristics



Frequency Hz Figure 图一

 	SPECIFICATION	PRODUCT	LINEAR VIBRATOR
		MODEL	LD0625BC
		REVISION NO.	REV.00

6、测试方法/Test Method

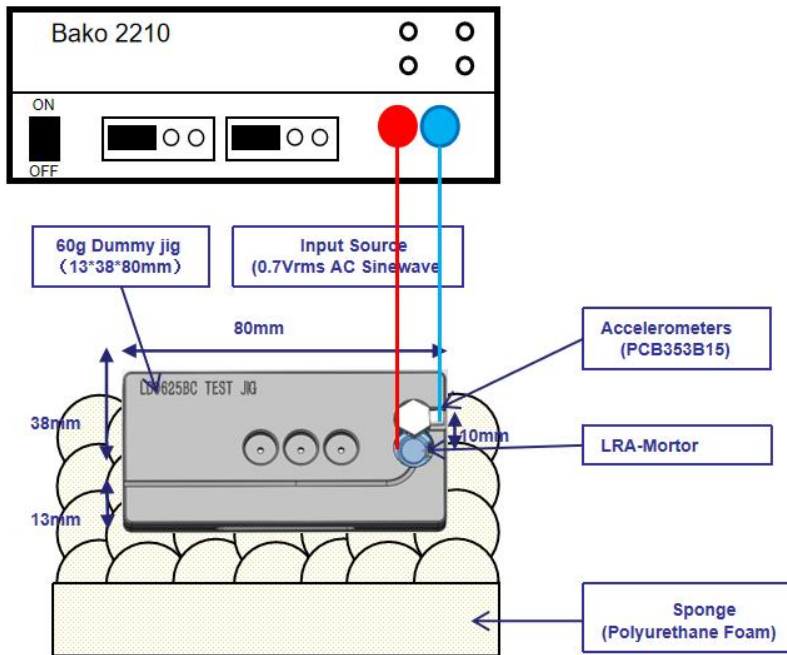

An Example of Measurement Method of Figure 2 测试方法 图 2

6-1 线性马达加速度测试安装位置(参考图 1)

Linear Vibrator/ Accelerometer mounting position (refer to Figure1)

6-2 将测试马达和加速度传感器按照上图指定尺寸位置固定好

Attach accelerometer and vibrator on the position on dummy jig according to the figure 1.

6-3 接通后 2-3 秒后读数.

Acceleration of linear vibrator should be measured 2~3 second later when source inputted

6-4 测试过程中，传感器与测试治具要固定牢固.



At measurement of acceleration, test jig and accelerometer should be stabilized.

6-5 为了测量数据准确，振动量数据取平均值.

For the precise measurement, acceleration of linear vibrator is average data.



6-6 在不影响判定结果的情况下，测试环境温度和湿度可以放宽至 5-35°C , 45%-85%RH.

If the judgment is not questionable, recognize measurement at 5°C to 35°C & relative humidity 45%RH to 85%RH.

 	SPECIFICATION	PRODUCT	LINEAR VIBRATOR
		MODEL	LD0625BC
		REVISION NO.	REV.00

7、可靠性实验/Reliability Test

项目/Item		测试条件/Test Condition	判定标准/Judgment
7-1	寿命 Lifetime test	1、试验循环/Test cycle: 500,000 cycle (1cycle: 2sec on/1sec off) 2、测试设备/Test equipment: 寿命试验机 /Lifetime test machine. 3、输入电压: 0.7VrmsAC, Sine wave 输入频率: 260Hz Input voltage: 0.7VrmsAC,Sine -wave Input frequency: 260Hz 备注/Remakr: 60g 治具	试验后,马达应符合第 8 项的要求/ The test result should meet the requirements of item 8.
7-2	低温放置 Low temperature storage test	温度/Temperature: $-30\pm 2^{\circ}\text{C}$ 时间/Time : 96H	在常温下放置 4 小时后, 马达应符合 第 8 项要求/ After 4-hour storage, the test result should meet the requirements of item8.
7-3	高温放置 High temperature storage test	温度/Temperature: $+70\pm 2^{\circ}\text{C}$ 时间/Time : 96H	
7-4	湿度放置 Humidity storage test	温度/Temperature: $+55\pm 2^{\circ}\text{C}$ 湿度/Humidity : 93%RH 时间/Time : 96H 无水气凝结/No condensation of moisture	
7-5	振动 Vibration test	全振幅: 1.5mm (p-p) 加速度: 3G 周期:90min (10-500Hz) 方向:x 、 y、 z	测试结果应符合第 8 项要求/ The test result should meet the requirements of item 8.

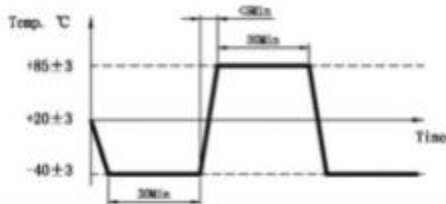
 	SPECIFICATION	PRODUCT	LINEAR VIBRATOR
		MODEL	LD0625BC
		REVISION NO.	REV.00
7-6	自然跌落 Drop test	<p>1、试验状态/Test status: 将马达固定在重量约 60g (包括马达本身) 的物体上, 落向水泥地面。</p> <p>Fix the motor on a object weighted about 60g (include the motor) and drop it to the cement floor.</p> <p>2、高度/Height: 1.0m</p> <p>3、方向/Direction: $\pm x, \pm y, \pm z$</p> <p>4、次数/ Number of the test: 每个方向 2 次/ times for each direction</p>	测试结果应符合第 8 项的要求/ The test result should meet the requirements of item 8.
7-7	滚筒试验 Tumbling	<p>高度: 1m</p> <p>次数: 300 次,</p> <p>滚筒速率: 13 ± 1 次/每分钟</p> <p>荷重: 60g</p>	
7-8	温度冲击试验 Temperature shock test	<p>测试模式/Test mode: 30min -40°C, 30min 85°C, as one cycle, Transfer time between extreme temperatures: <5 分钟</p> <p>/5min 循环次数: 15cycles</p> 	在常温下放置 4 小时后, 测试结果应符合第 8 项要求/ After 4 hour exposure in ordinary temperature and humidity and the test result should meet the requirements of item 8.

8、判断特性/Requirements after reliable test



8-1 试验后应满足下列条件

- F0 点振动量/Acceleration: 初始值/Initial Value $\pm 10\%$
- 额定电流/Rated current: 初始值 Initial Value $\pm 30\%$
- F0/Frequency: 初始值 Initial Value $\pm 10\text{Hz}$
- 噪音/Noise: 50dB(A) Max

8-2 试验完毕后需在标准测试条件下放置 4 小时后再测试。

The measurement is conducted after 4 hours of recovery under standard test condition after reliability test.

8-3 外表和结构无异常。 There should be no abnormalities in appearance and structure.

 	SPECIFICATION	PRODUCT	LINEAR VIBRATOR
		MODEL	LD0625BC
		REVISION NO.	REV.00

9、使用注意事项/ Points for Attentions

9-1. 必须按照规格书标准使用, 否则性能与寿命都将受到相当的减少, 必须注意电压的使用范畴.

Make sure to use the motor in accordance with the specifications, if not, the lifetime might be reduced accordingly, pay high attention to the range of the voltage.

9-2. 建议马达在 6 个月内使用, 不要在以下环境中使用及保存.

9-2-1. 高温与高湿的场所.

9-2-2. 腐蚀性气体, 如: H₂S, SO₂, NO₂, CL₂;

9-2-3. 生锈场所;

The motor is suggested using within 6 months. Do not use or store the motor under below environments:

9-2-1. High temperature and high humidity area;

9-2-2. Corrosive gas such as H₂S, SO₂, NO₂, CL₂;

9-2-3. Rusty place;

9-3. 注意处理马达的工作环境, 避免含铁质物体被马达吸住, 否则马达将会产生噪音, 性能会降低, 从而降低产品的可靠性.

Pay attention to the working environment of the motor, avoid any iron material sucked by the motor, or the motor might cause noise and the performance will be degraded, meanwhile, the reliability might be reduced.

9-4. 应确信本产品不会违背相关的标准, 以及法律法规与行政令.

Make sure the product will not violate any local relevant standards, as well as laws and regulations.

9-5. 拿马达时, 要轻拿轻放.



Handle with care.

9-6. 钢板面边缘有少许锈斑是允许的.

A little rusty spot at the steel plate surface is allowed.

9-7. 我司遵循持续发展的策略, 在不预先通知的情况下, 有对产品 (部品) 进行修改和改进的权利, 当然这些都不会影响马达的特性及使用功能.

Our company follow the sustainable developing strategy, and have the right to make change and improvements to our product without giving notice in advance . of course ,these changes and improvements will not affect the characteristics and function of the motor.

 	SPECIFICATION	PRODUCT	LINEAR VIBRATOR
		MODEL	LD0625BC
		REVISION NO.	REV.00

10、包装/Packing

线性马达系列包装 Linear Motor Series Packaging

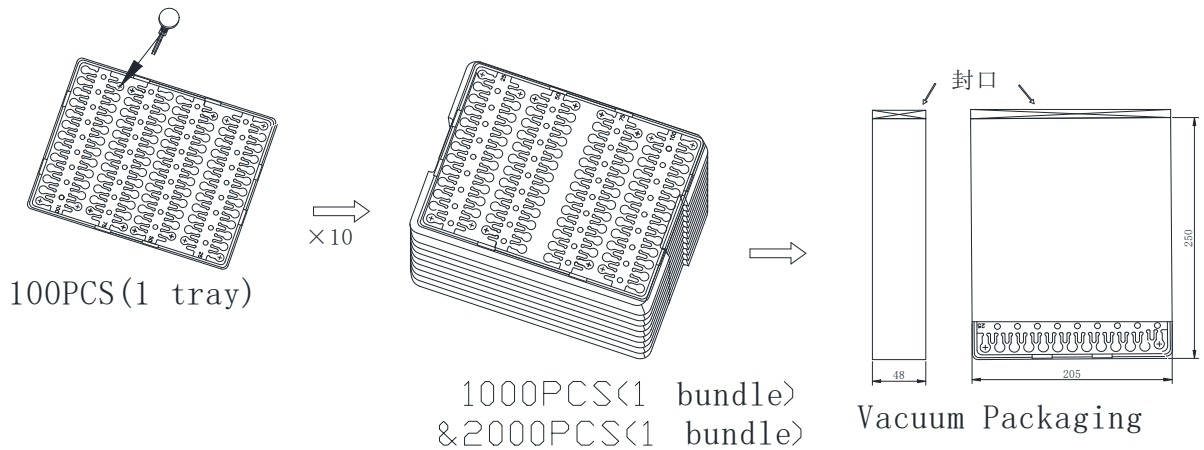

包装尺寸/Packaging Size:

10000PCS/CARTON:
CARTON SIZE: 430mm*270mm*220mm



包装试验要求:

Packaging test requirements:

沿外包装箱±x, ±y和±z方向, 距水泥地面1.5m高度, 各自由跌落2次, 马达应无机械损伤, 电气性能仍符合标准要求。

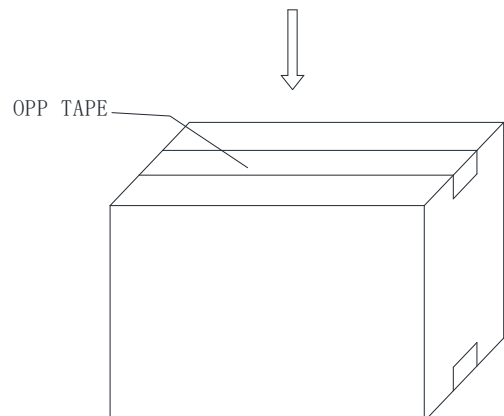
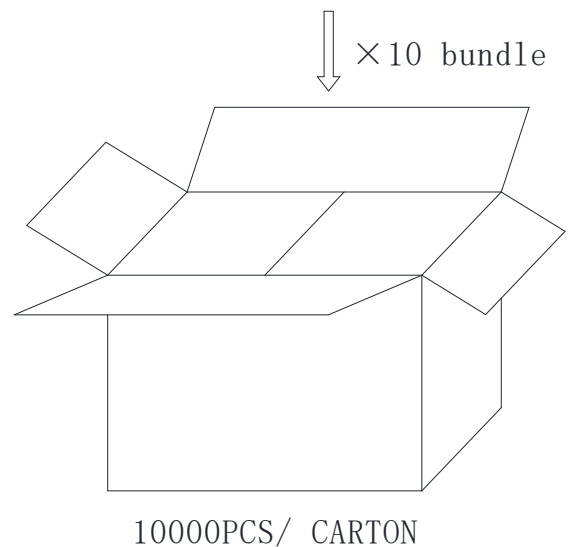
Along the outer packing box + X, + y and + Z direction, from the cement ground 1.5m height, the free fall 2 times, the motor should have no mechanical damage, electrical performance is still in line with the standard requirements.



 	<h1 style="margin: 0;">SPECIFICATION</h1>	PRODUCT	LINEAR VIBRATOR
		MODEL	LD0625BC
		REVISION NO.	REV.00

11、外形图/ Outline drawing

