

RAM Mapping 32x4 LCD Controller for I/O MCU

The HT1621 is a 128 pattern (32x4), memory mapping, and multi-function LCD driver. The S/W configuration feature of the HT1621 makes it suitable for multiple LCD applications including LCD modules and display sub-systems. Only three or four lines are required for the interface between the host controller and the HT1621. The HT1621 contains a power down command to reduce power consumption.

Features

- Operating voltage: 2.4V ~ 5.2V
- Built-in 256kHz RC oscillator
- External 32.768kHz crystal or 256 kHz frequency source input
- Selection of 1/2 or 1/3 bias, and selection of 1/2 or 1/3 or 1/4 duty LCD applications
- Internal time base frequency sources
- Two selectable buzzer frequencies (2kHz/4kHz)
- Power down command reduces power consumption
- Built-in time base generator and a WDT
- Time base or WDT overflow output
- 8 kinds of time base/WDT clock sources
- 32x4 LCD driver
- Built-in 32x4 bit display RAM
- 3-wire serial interface
- Internal LCD driving frequency source
- Software configuration feature
- Data mode and command mode instructions
- R/W address auto increment
- Three data accessing modes
- VLCD pin for adjusting LCD operating voltage
- HT1621B: 48-pin SSOP48 packages
- HT1621B: 48-pin LQFP48 packages
- HT1621B: 48-pin QFN48 packages
- HT1621B: 44-pin LQFP44 packages
- HT1621D: 28-pin SKDIP28 package
- HT1621G: 48-pad Gold bumped chip

ORDERING INFORMATION

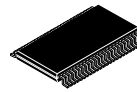

SSOP48
RS
SUFFIX
HT1621BRSZ



LQFP48_7*7
RQ
SUFFIX
HT1621ARQZ48
HT1621BRQZ48

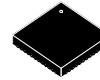

QFN48_7*7
RQN
SUFFIX
HT1621BRQNZ48

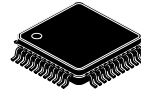

LQFP44_10*10
RQ
SUFFIX
HT1621BRQZ44

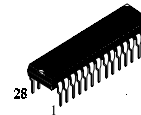

DIP28 N
SUFFIX
HT1621BNZ

&HT1621 = Specific Device Code
 &A,B = Version
 &RS,RQ,RQN, N = Reel,Package
 &Z = Pb-Free Package
 &#yyywww = Year,Wafer Lot

T_A = -40° to 125°C for all packages

Selection Table

HT162x	HT1620	HT1621	HT1622	HT16220	HT1623	HT1625	HT1626
COM	4	4	8	8	8	8	16
SEG	32	32	32	32	48	64	48
Built-in Osc.	—	√	√	—	√	√	√
Crystal Osc.	√	√	—	√	√	√	√

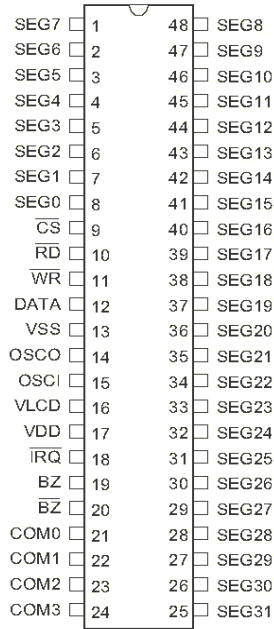
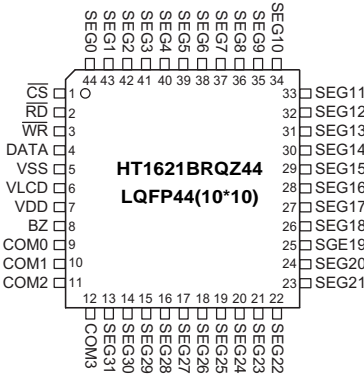
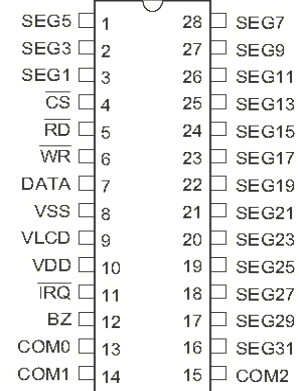
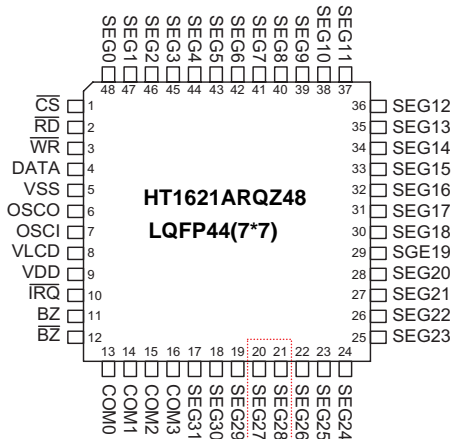
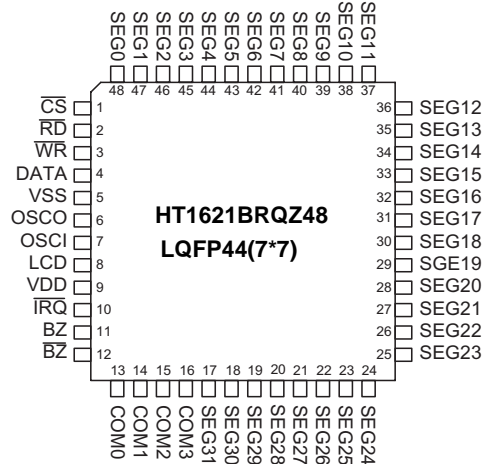
Pin Assignment

**HT1621BRSZ
SSOP48**

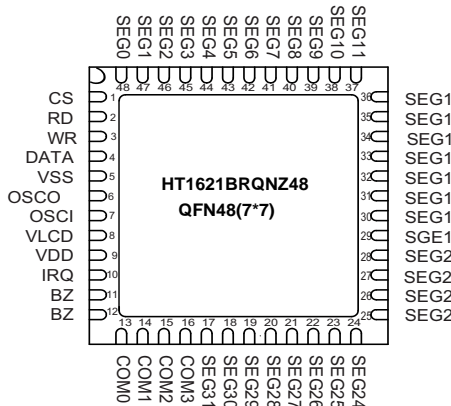
**HT1621BRQZ44
LQFP44(10*10)**

**HT1621BNZ
DIP28**

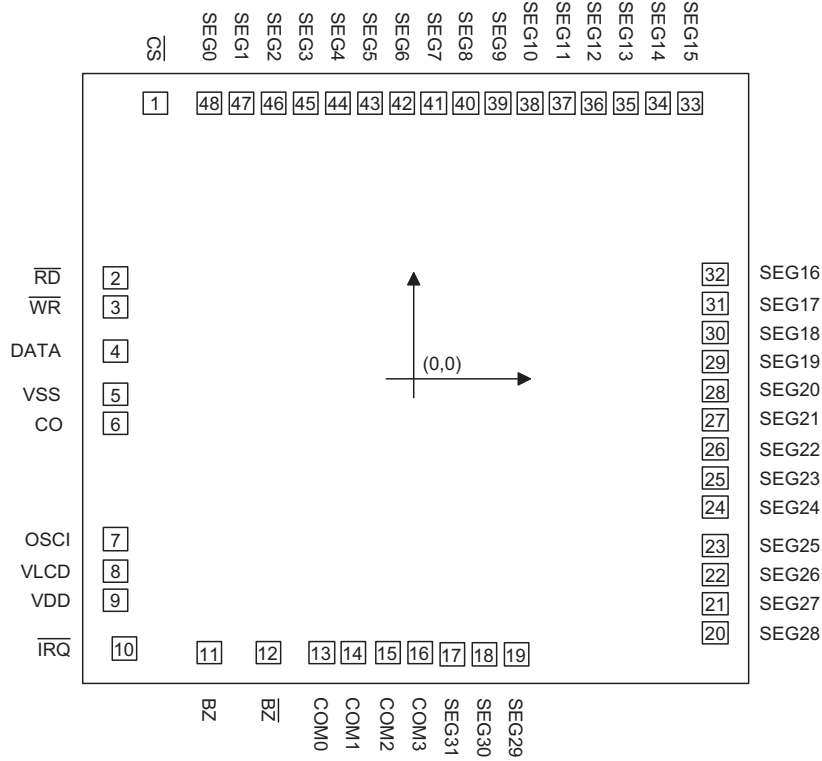
**HT1621ARQZ48
LQFP44(7*7)**

**HT1621BRQZ48
LQFP44(7*7)**

Note: * Please note that in the 48-pin LQFP package, the SEG27 and SEG28 pins are not in sequential order.

**HT1621BRQNZ48
QFN48(7*7)**

Pad Assignment



Chip size: 62 × 63 (mil)²

Bump height: 18μm ± 3μm

Min. Bump spacing: 23.02μm

Bump size: 76 × 76μm²

* The IC substrate should be connected to VDD in the PCB layout artwork.

Block Diagram

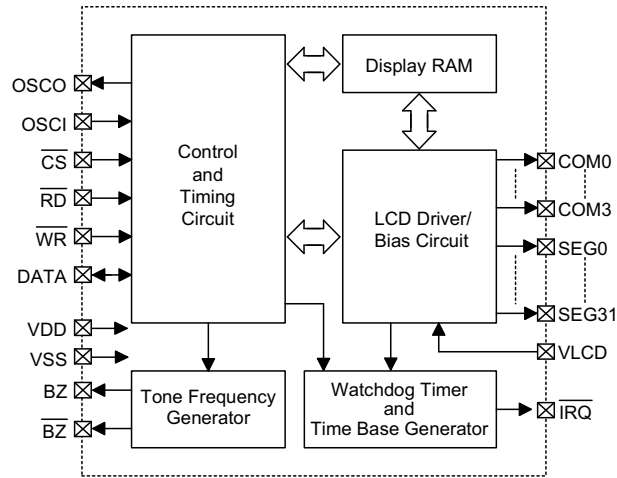

Note: $\overline{\text{CS}}$: Chip selection
 $\overline{\text{BZ}}$, $\overline{\text{BZ}}$: Tone outputs
 $\overline{\text{WR}}$, $\overline{\text{RD}}$, DATA: Serial interface
 COM0~COM3, SEG0~SEG31: LCD outputs
 $\overline{\text{IRQ}}$: Time base or WDT overflow output

Pad Coordinates

 Unit: μm

Pad No.	X	Y	Pad No.	X	Y
1	-802.951	939.295	25	925.915	-338.315
2	-927.055	343.250	26	925.915	-239.255
3	-927.055	244.230	27	925.915	-140.195
4	-927.055	89.374	28	925.915	-41.134
5	-925.358	-52.510	29	925.915	57.925
6	-925.358	-151.360	30	925.915	156.986
7	-925.785	-566.516	31	925.915	256.046
8	-925.785	-675.287	32	925.915	355.106
9	-925.699	-773.697	33	849.589	939.295
10	-896.840	-939.537	34	750.530	939.295
11	-637.515	-935.685	35	651.469	939.295
12	-452.726	-935.685	36	552.409	939.295
13	-288.935	-935.685	37	453.349	939.295
14	-189.915	-935.685	38	354.289	939.295
15	-84.350	-935.685	39	255.230	939.295
16	14.669	-935.685	40	156.169	939.295
17	114.260	-940.130	41	57.109	939.295
18	213.320	-940.130	42	-41.951	939.295
19	312.380	-940.130	43	-141.010	939.295
20	925.915	-867.615	44	-240.070	939.295
21	925.915	-768.555	45	-339.130	939.295
22	925.915	-669.495	46	-438.190	939.295
23	925.915	-570.435	47	-537.250	939.295
24	925.915	-437.375	48	-636.310	939.295

Pad Description

Pad No.	Pad Name	I/O	Function
1	$\overline{\text{CS}}$	I	Chip selection input with pull-high resistor When the $\overline{\text{CS}}$ is logic high, the data and command read from or written to the HT1621 are disabled. The serial interface circuit is also reset. But if $\overline{\text{CS}}$ is at logic low level and is input to the $\overline{\text{CS}}$ pad, the data and command transmission between the host controller and the HT1621 are all enabled.
2	$\overline{\text{RD}}$	I	READ clock input with pull-high resistor Data in the RAM of the HT1621 are clocked out on the falling edge of the $\overline{\text{RD}}$ signal. The clocked out data will appear on the DATA line. The host controller can use the next rising edge to latch the clocked out data.
3	$\overline{\text{WR}}$	I	WRITE clock input with pull-high resistor Data on the DATA line are latched into the HT1621 on the rising edge of the $\overline{\text{WR}}$ signal.
4	DATA	I/O	Serial data input/output with pull-high resistor
5	VSS	—	Negative power supply, ground
7	OSCI	I	The OSCI and OSCO pads are connected to a 32.768kHz crystal in order to generate a system clock. If the system clock comes from an external clock source, the external clock source should be connected to the OSCI pad. But if an on-chip RC oscillator is selected instead, the OSCI and OSCO pads can be left open.
6	OSCO	O	
8	VLCD	I	LCD power input
9	VDD	—	Positive power supply
10	$\overline{\text{IRQ}}$	O	Time base or WDT overflow flag, NMOS open drain output
11, 12	BZ, $\overline{\text{BZ}}$	O	2kHz or 4kHz tone frequency output pair
13~16	COM0~COM3	O	LCD common outputs
48~17	SEG0~SEG31	O	LCD segment outputs

Absolute Maximum Ratings

Supply Voltage	$V_{SS}-0.3V$ to $V_{SS}+5.5V$
Input Voltage	$V_{SS}-0.3V$ to $V_{DD}+0.3V$
Operating Temperature.....	$-40^{\circ}C$ to $85^{\circ}C$
Storage Temperature.....	$-60^{\circ}C$ to $150^{\circ}C$

Note: These are stress ratings only. Stresses exceeding the range specified under "Absolute Maximum Ratings" may cause substantial damage to the device. Functional operation of this device at other conditions beyond those listed in the specification is not implied and prolonged exposure to extreme conditions may affect device reliability.

D.C. Characteristics

 $T_a=25^{\circ}C$

Symbol	Parameter	Test Conditions		Min.	Typ.	Max.	Unit
		V_{DD}	Conditions				
V_{DD}	Operating Voltage	—	—	2.4	—	5.2	V
I_{DD1}	Operating Current	3V	No load/LCD ON	—	150	300	μA
		5V	On-chip RC oscillator	—	300	600	μA
I_{DD2}	Operating Current	3V	No load/LCD ON	—	60	120	μA
		5V	Crystal oscillator	—	120	240	μA
I_{DD3}	Operating Current	3V	No load/LCD ON	—	100	200	μA
		5V	External clock source	—	200	400	μA
I_{STB}	Standby Current	3V	No load, Power down mode	—	0.1	5	μA
		5V		—	0.3	10	μA
V_{IL}	Input Low Voltage	3V	DATA, \overline{WR} , \overline{CS} , \overline{RD}	0	—	0.6	V
		5V		0	—	1.0	V
V_{IH}	Input High Voltage	3V	DATA, \overline{WR} , \overline{CS} , \overline{RD}	2.4	—	3.0	V
		5V		4.0	—	5.0	V
I_{OL1}	DATA, BZ, \overline{BZ} , \overline{IRQ}	3V	$V_{OL}=0.3V$	0.5	1.2	—	mA
		5V	$V_{OL}=0.5V$	1.3	2.6	—	mA
I_{OH1}	DATA, BZ, \overline{BZ}	3V	$V_{OH}=2.7V$	-0.4	-0.8	—	mA
		5V	$V_{OH}=4.5V$	-0.9	-1.8	—	mA
I_{OL2}	LCD Common Sink Current	3V	$V_{OL}=0.3V$	80	150	—	μA
		5V	$V_{OL}=0.5V$	150	250	—	μA
I_{OH2}	LCD Common Source Current	3V	$V_{OH}=2.7V$	-80	-120	—	μA
		5V	$V_{OH}=4.5V$	-120	-200	—	μA
I_{OL3}	LCD Segment Sink Current	3V	$V_{OL}=0.3V$	60	120	—	μA
		5V	$V_{OL}=0.5V$	120	200	—	μA
I_{OH3}	LCD Segment Source Current	3V	$V_{OH}=2.7V$	-40	-70	—	μA
		5V	$V_{OH}=4.5V$	-70	-100	—	μA
R_{PH}	Pull-high Resistor	3V	DATA, \overline{WR} , \overline{CS} , \overline{RD}	60	120	200	k Ω
		5V		30	60	100	k Ω

A.C. Characteristics

Ta=25°C

Symbol	Parameter	Test Conditions		Min.	Typ.	Max.	Unit
		V _{DD}	Conditions				
f _{SYS1}	System Clock	3V	On-chip RC oscillator	192	256	320	kHz
f _{SYS2}	System Clock	—	Crystal oscillator	—	32768	—	Hz
f _{SYS3}	System Clock	—	External clock source	—	256	—	kHz
f _{LCD}	LCD Clock	—	On-chip RC oscillator	—	f _{SYS1} /1024	—	Hz
		—	Crystal oscillator	—	f _{SYS2} /128	—	Hz
		—	External clock source	—	f _{SYS3} /1024	—	Hz
t _{COM}	LCD Common Period	—	n: Number of COM	—	n/f _{LCD}	—	s
f _{CLK1}	Serial Data Clock (\overline{WR} pin)	3V	Duty cycle 50%	4	—	150	kHz
		5V		4	—	300	
f _{CLK2}	Serial Data Clock (\overline{RD} pin)	3V	Duty cycle 50%	—	—	75	kHz
		5V		—	—	150	
f _{TONE}	Tone Frequency (2kHz)	3V	On-chip RC oscillator	1.5	2.0	2.5	kHz
	Tone Frequency (4kHz)			3.0	4.0	5.0	
t _{CS}	Serial Interface Reset Pulse Width (Figure 3)	—	\overline{CS}	250	300	—	ns
t _{CLK}	\overline{WR} , \overline{RD} Input Pulse Width (Figure 1)	3V	Write mode	3.34	—	125	μs
			Read mode	6.67	—	—	
		5V	Write mode	1.67	—	125	μs
			Read mode	3.34	—	—	
t _r , t _f	Rise/Fall Time Serial Data Clock Width (Figure 1)	—	—	—	120	160	ns
t _{SU}	Setup Time for DATA to \overline{WR} , \overline{RD} Clock Width (Figure 2)	—	—	60	120	—	ns
t _H	Hold Time for DATA to \overline{WR} , \overline{RD} Clock Width (Figure 2)	—	—	250	300	—	ns
t _{SU1}	Setup Time for \overline{CS} to \overline{WR} , \overline{RD} Clock Width (Figure 3)	—	—	500	600	—	ns
t _{H1}	Hold Time for \overline{CS} to \overline{WR} , \overline{RD} Clock Width (Figure 3)	—	—	250	300	—	ns
t _{OFF}	V _{DD} OFF Time (Figure 4)	—	V _{DD} drop down to 0V	20	—	—	ms
t _{SR}	V _{DD} Rising Slew Rate (Figure 4)	—	—	0.05	—	—	V/ms
t _{RSTD}	Delay Time after Reset (Figure 4)	—	—	1	—	—	ms

Note: 1. If the conditions of Power-on Reset timing are not satisfied in power On/Off sequence, the internal Power-on Reset (POR) circuit will not operate normally.

2. If the V_{DD} drops below the minimum voltage of operating voltage spec. during operating, the conditions of Power-on Reset timing must be satisfied also. That is, the V_{DD} must drop to 0V and keep at 0V for 20ms (min.) before rising to the normal operating voltage.

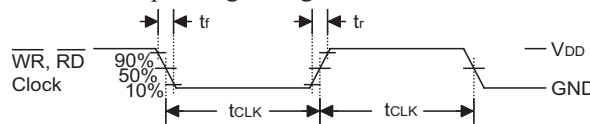
Figure 1

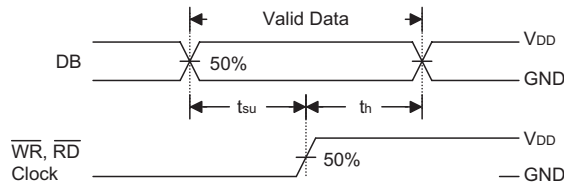

Figure 2

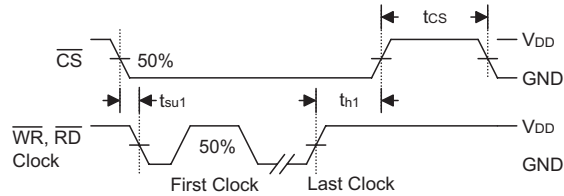

Figure 3

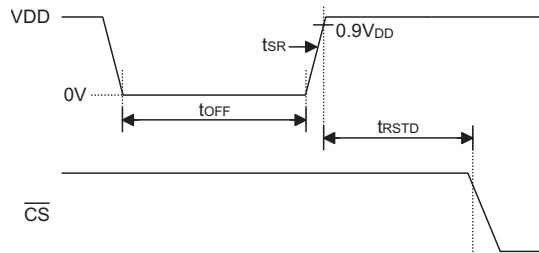

Figure 4 Power-on Reset Timing

Functional Description

Display Memory – RAM

The static display memory (RAM) is organized into 32×4 bits and stores the displayed data. The contents of the RAM are directly mapped to the contents of the LCD driver. Data in the RAM can be accessed by the READ, WRITE, and READ-MODIFY-WRITE commands. The following is a mapping from the RAM to the LCD pattern:

	COM3	COM2	COM1	COM0	
SEG0					0
SEG1					1
SEG2					2
SEG3					3
...					...
SEG31					31
	D 3	D 2	D 1	D 0	Addr Data

Data 4 bits
(D3, D2, D1, D0)

Address 6 bits
(A5, A4, ..., A0)

RAM Mapping

System Oscillator

The HT1621 system clock is used to generate the time base/Watchdog Timer (WDT) clock frequency, LCD driving clock, and tone frequency. The source of the clock may be from an on-chip RC oscillator (256kHz), a crystal oscillator (32.768kHz), or an external 256kHz clock by the S/W setting. The configuration of the system oscillator is as shown. After the SYS DIS command is executed, the system clock will stop and the LCD bias generator will turn off. That command is, however, available only for the on-chip RC oscillator or for the crystal oscillator. Once the system clock stops, the LCD display will become blank, and the time base/WDT lose its function as well.

The LCD OFF command is used to turn the LCD bias generator off. After the LCD bias generator switches off by issuing the LCD OFF command, using the SYS DIS command reduces power consumption, serving as a system power down command. But if the external clock source is chosen as the system clock, using the SYS DIS command can neither turn the oscillator off nor carry out the power down mode. The crystal oscillator option can be applied to connect an external frequency source of 32kHz to the OSCI pin. In this case, the system fails to enter the power down mode, similar to the case in the external 256kHz clock source operation. At the initial system power on, the HT1621 is at the SYS DIS state.

Time Base and Watchdog Timer (WDT)

The time base generator is comprised by an 8-stage count-up ripple counter and is designed to generate an accurate time base. The watch dog timer (WDT), on the other hand, is composed of an 8-stage time base generator along with a 2-stage count-up counter, and is designed to break the host controller or other subsystems from abnormal states such as unknown or unwanted jump, execution errors, etc. The WDT time-out will result in the setting of an internal WDT time-out flag. The outputs of the time base generator and of the WDT time-out flag can be connected to the $\overline{\text{IRQ}}$ output by a command option. There are totally eight frequency sources available for the time base generator and the WDT clock. The frequency is calculated by the following equation.

$$f_{\text{WDT}} = \frac{32\text{kHz}}{2^n}$$

where the value of n ranges from 0 to 7 by command options. The 32kHz in the above equation indicates that the source of the system frequency is derived from a crystal oscillator of 32.768kHz, an on-chip oscillator (256kHz), or an external frequency of 256kHz.

If an on-chip oscillator (256kHz) or an external 256kHz frequency is chosen as the source of the system frequency, the frequency source is by default prescaled to 32kHz by a 3-stage prescaler. Employing both the time base generator and the WDT related commands, one should be careful since the time base generator and WDT share the same 8-stage counter. For example, invoking the WDT DIS command disables the time base generator whereas executing the WDT EN command not only enables the time base generator but activates the WDT time-out flag output (connect the WDT time-out flag to the $\overline{\text{IRQ}}$ pin). After the TIMER EN command is transferred, the WDT is disconnected from the $\overline{\text{IRQ}}$ pin, and the output of the time base generator is connected to the $\overline{\text{IRQ}}$ pin. The WDT can be cleared by executing the CLR WDT command, and the contents of the time base generator is cleared by executing the CLR WDT or the CLR TIMER command. The CLR WDT or the CLR TIMER command should be executed prior to the WDT EN or the TIMER EN command respectively. Before executing the $\overline{\text{IRQ}}$ EN command the CLR WDT or CLR TIMER command should be executed first. The CLR TIMER command has to be executed before switching from the WDT mode to the time base mode. Once the WDT time-out occurs, the $\overline{\text{IRQ}}$ pin will stay at a logic low level until the CLR WDT or the $\overline{\text{IRQ}}$ DIS command is issued. After the $\overline{\text{IRQ}}$ output is disabled the $\overline{\text{IRQ}}$ pin will remain at the floating state. The $\overline{\text{IRQ}}$ output can be enabled or disabled by executing the $\overline{\text{IRQ}}$ EN or the $\overline{\text{IRQ}}$ DIS command, respectively. The $\overline{\text{IRQ}}$ EN makes the output

of the time base generator or of the WDT time-out flag appear on the $\overline{\text{IRQ}}$ pin. The configuration of the time base generator along with the WDT are as shown. In the case of on-chip RC oscillator or crystal oscillator, the power down mode can reduce power consumption since the oscillator can be turned on or off by the corresponding system commands. At the power down mode the time base/WDT loses all its functions.

On the other hand, if an external clock is selected as the source of system frequency the SYS DIS command turns out invalid and the power down mode fails to be carried out. That is, after the external clock source is selected, the HT1621 will continue working until system power fails or the external clock source is removed. After the system power on, the $\overline{\text{IRQ}}$ will be disabled.

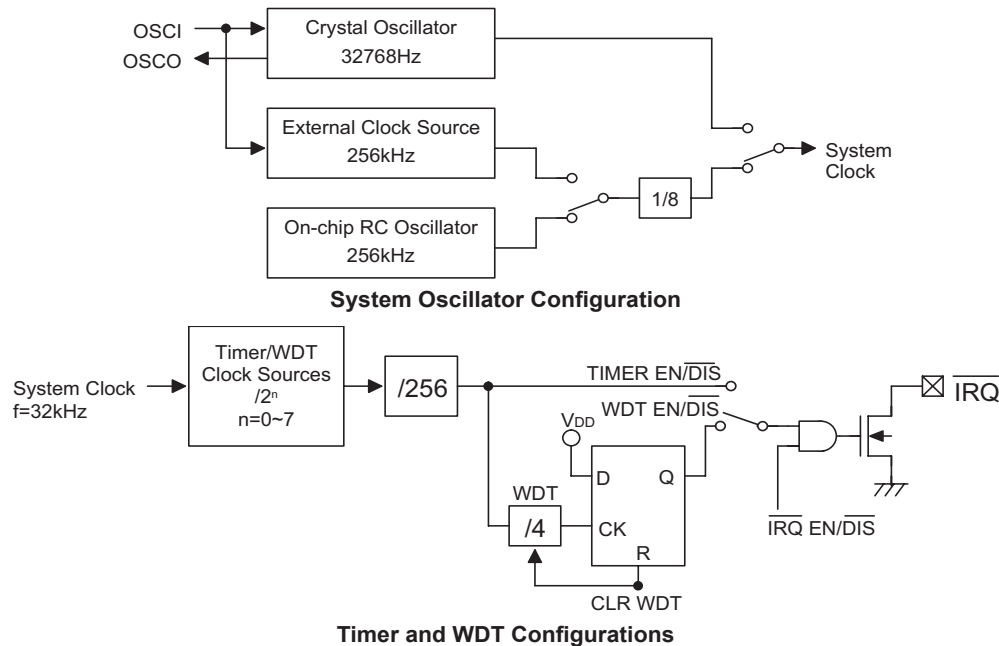

Tone Output

A simple tone generator is implemented in the HT1621. The tone generator can output a pair of differential driving signals on the BZ and $\overline{\text{BZ}}$, which are used to generate a single tone. By executing the TONE 4K and TONE 2K commands there are two tone frequency outputs selectable. The TONE 4K and TONE 2K commands set the tone frequency to 4kHz and 2kHz, respectively. The tone output can be turned on or off by invoking the TONE ON or the TONE OFF command. The tone outputs, namely BZ and $\overline{\text{BZ}}$, are a pair of differential driving outputs used to drive a piezo buzzer. Once the system is disabled or the tone output is inhibited, the BZ and the $\overline{\text{BZ}}$ outputs will remain at low level.

LCD Driver

The HT1621 is a 128 (32×4) pattern LCD driver. It can be configured as 1/2 or 1/3 bias and 2 or 3 or 4 commons of LCD driver by the S/W configuration. This feature makes the HT1621 suitable for multiply LCD applications. The LCD driving clock is derived from the system clock. The value of the driving clock is always 256Hz even when it is at a 32.768kHz crystal oscillator frequency, an on-chip RC oscillator frequency, or an external frequency. The LCD corresponding commands are summarized in the table.

The bold form of 1 0 0, namely **1 0 0**, indicates the command mode ID. If successive commands have been issued, the command mode ID except for the first command, will be omitted. The LCD OFF command turns the LCD display off by disabling the LCD bias generator. The LCD ON

command, on the other hand, turns the LCD display on by enabling the LCD bias generator. The BIAS and COM are the LCD panel related commands. Using the LCD related commands, the HT1621 can be compatible with most types of LCD panels.

Name	Command Code	Function
LCD OFF	1 0 0 0 0 0 0 0 0 1 0 X	Turn off LCD outputs
LCD ON	1 0 0 0 0 0 0 0 0 1 1 X	Turn on LCD outputs
BIAS & COM	1 0 0 0 0 1 0 a b X c X	c=0: 1/2 bias option c=1: 1/3 bias option ab=00: 2 commons option ab=01: 3 commons option ab=10: 4 commons option

Command Format

The HT1621 can be configured by the S/W setting. There are two mode commands to configure the HT1621 resources and to transfer the LCD display data. The configuration mode of the HT1621 is called command mode, and its command mode ID is **1 0 0**. The command mode consists of a system configuration command, a system frequency selection command, a LCD configuration command, a tone frequency selection command, a timer/WDT setting command, and an operating command. The data mode, on the other hand, includes READ, WRITE, and READ-MODIFY-WRITE operations. The following are the data mode IDs and the command mode ID:

Operation	Mode	ID
Read	Data	1 1 0
Write	Data	1 0 1
Read-Modify-Write	Data	1 0 1
Command	Command	1 0 0

The mode command should be issued before the data or command is transferred. If successive commands have been issued, the command mode ID, namely **1 0 0**, can be omitted. While the system is operating in the non-successive command or the non-successive address data mode, the \overline{CS} pin should be set to "1" and the previous operation mode will be reset also. Once the \overline{CS} pin returns to "0" a new operation mode ID should be issued first.

Interfacing

Only four lines are required to interface with the HT1621. The \overline{CS} line is used to initialize the serial interface circuit and to terminate the communication between the host controller and the HT1621. If the \overline{CS} pin is set to 1, the data and command issued between the host controller and the HT1621 are first disabled and then initialized. Before issuing a mode command or mode switching, a high level pulse is required to initialize the serial interface of the HT1621. The DATA line is the serial data input/output line. Data to be read or written or commands to be written have to be passed through the DATA line. The \overline{RD} line is the READ clock input. Data in the RAM are clocked out on the falling edge of the \overline{RD} signal, and the clocked out data will then appear on the DATA line. It is recommended that the host controller read in correct data during the interval between the rising edge and the next falling edge of the \overline{RD} signal. The \overline{WR} line is the WRITE clock input. The data, address, and command on the DATA line are all clocked into the HT1621 on the rising edge of the \overline{WR} signal. There is an optional \overline{IRQ} line to be used as an interface between the host controller and the HT1621. The \overline{IRQ} pin can be selected as a timer output or a WDT overflow flag output by the S/W setting. The host controller can perform the time base or the WDT function by being connected with the \overline{IRQ} pin of the HT1621.

Crystal Selection

A 32768Hz crystal can be directly connected to the HT1621 via OSCI and OSCO. In order to obtain the correct frequency, two additional load capacities (C1, C2) are needed. The value of the capacity depends on how accurate the crystal is. The table illustrates the suggestion value of capacities (C1, C2).

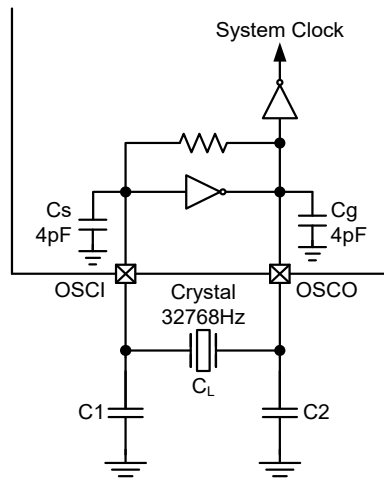

Crystal Specifications:

Symbol	Parameter	Min.	Typ.	Max.	Unit
f_o	Nominal Frequency	—	32768	—	Hz
R_s (ESR)	Series Resistance	—	30	50	k Ω
C_L	Load Capacitance	—	12.5	—	pF

Note: The oscillator selection can be optimized by using a high quality resonator with a small ESR value.

Crystal Load Capacitance (C_L) (ESR \leq 50k Ω)	Load Capacitance of Capacities (C1, C2) (C1=C2)
7pF	10pF
9pF	14pF
12.5pF	21pF

The C1/C2 capacity value is calculated as follows:

$$(C1//C2)=C_L-(C_s//C_g), \text{ If } C1=C2 \text{ and then } C1=(C_L-(C_s//C_g))\times 2$$

C_L : load capacitive for which the crystal

C_s/C_g : integrated load capacitor ($C_s=C_g=4\text{pF}$), $(C_s//C_g)=2\text{pF}$

Timing Diagrams

READ Mode (Command Code : 1 1 0)

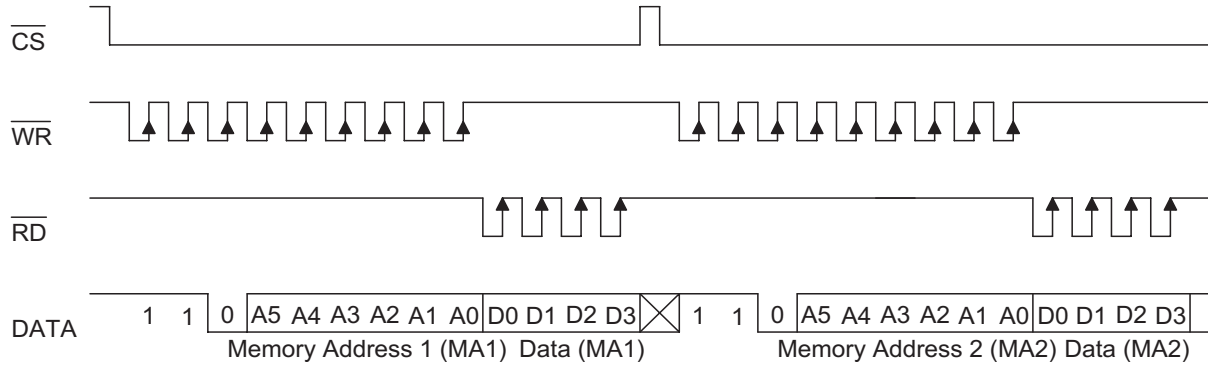

READ Mode (Successive Address Reading)

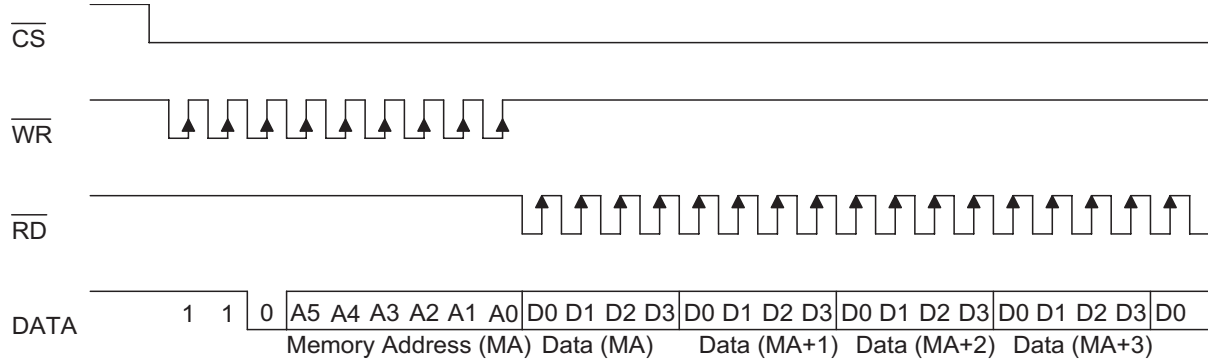

WRITE Mode (Command Code : 1 0 1)

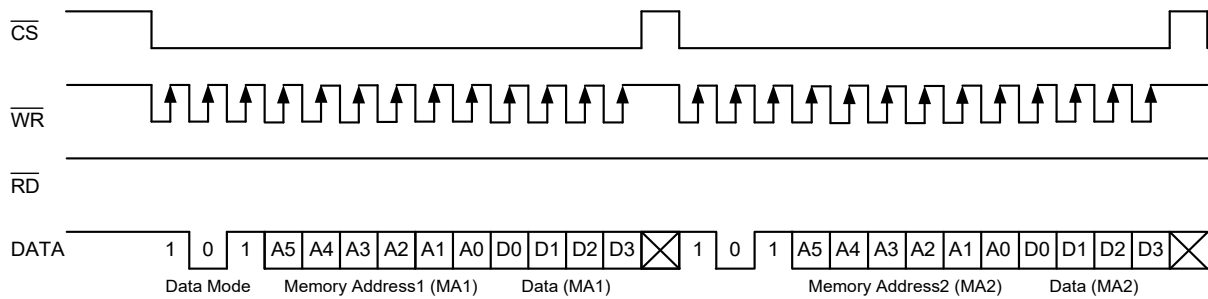

WRITE Mode (Successive Address Writing)

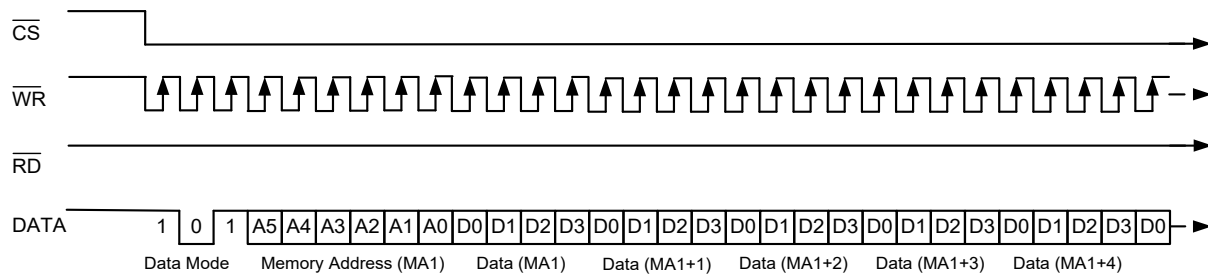

Application Circuits

Host Controller with an HT1621 Display System

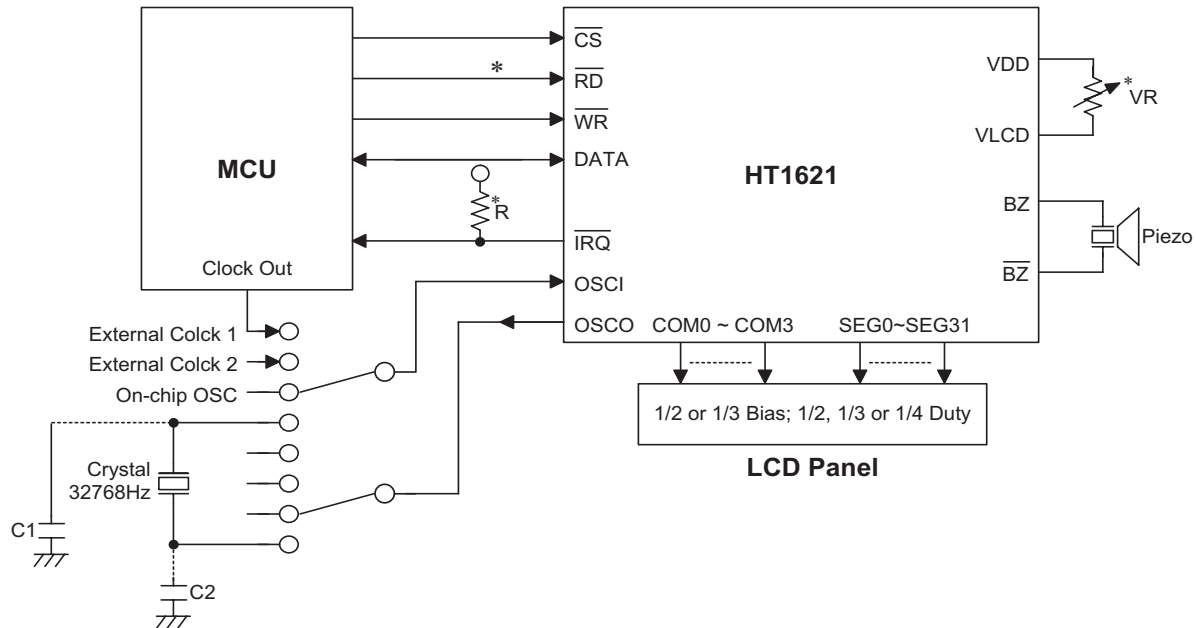

Note: The connection of $\overline{\text{IRQ}}$ and $\overline{\text{RD}}$ pin can be selected depending on the requirement of the MCU.

The voltage applied to V_{LCD} pin must be equal to or lower than V_{DD} .

Adjust VR to fit user's LCD panel display voltage (V_{LCD}).

Adjust R (external pull-high resistance) to fit user's time base clock.

In order to obtain the accuracy of the frequency is dependent upon the accuracy of the crystal and the accuracy of the match between the capacitive load of the oscillator circuit and the capacitive load (C1/C2) for which the crystal was trimmed.

The C1/C2 capacity value is calculated as follows:

$$(C1/C2) = C_L - (C_s // C_g), \text{ If } C1 = C2 \text{ and then } C1 = (C_L - (C_s // C_g)) \times 2$$

C_L : load capacitive for which the crystal

C_s/C_g : integrated load capacitor ($C_s = C_g = 4\text{pf}$), ($C_s // C_g$) = 2pF

Crystal Load Capacitance (C_L) ($\text{ESR} \leq 50\text{k}\Omega$)	Load Capacitance of Capacities ($C1, C2$) ($C1 = C2$)
7pF	10pF
9pF	14pF
12.5pF	21pF

Command Summary

Name	ID	Command Code	D/C	Function	Def.
READ	1 1 0	A5A4A3A2A1A0D0D1D2D3	D	Read data from the RAM	
WRITE	1 0 1	A5A4A3A2A1A0D0D1D2D3	D	Write data to the RAM	
READ-MODIFY-WRITE	1 0 1	A5A4A3A2A1A0D0D1D2D3	D	READ and WRITE to the RAM	
SYS DIS	1 0 0	0000-0000-X	C	Turn off both system oscillator and LCD bias generator	Yes
SYS EN	1 0 0	0000-0001-X	C	Turn on system oscillator	
LCD OFF	1 0 0	0000-0010-X	C	Turn off LCD bias generator	Yes
LCD ON	1 0 0	0000-0011-X	C	Turn on LCD bias generator	
TIMER DIS	1 0 0	0000-0100-X	C	Disable time base output	

Name	ID	Command Code	D/C	Function	Def.
WDT DIS	1 0 0	0000-0101-X	C	Disable WDT time-out flag output	
TIMER EN	1 0 0	0000-0110-X	C	Enable time base output	
WDT EN	1 0 0	0000-0111-X	C	Enable WDT time-out flag output	
TONE OFF	1 0 0	0000-1000-X	C	Turn off tone outputs	Yes
TONE ON	1 0 0	0000-1001-X	C	Turn on tone outputs	
CLR TIMER	1 0 0	0000-11XX-X	C	Clear the contents of time base generator	
CLR WDT	1 0 0	0000-111X-X	C	Clear the contents of WDT stage	
XTAL 32K	1 0 0	0001-01XX-X	C	System clock source, crystal oscillator	
RC 256K	1 0 0	0001-10XX-X	C	System clock source, on-chip RC oscillator	Yes
EXT 256K	1 0 0	0001-11XX-X	C	System clock source, external clock source	
BIAS 1/2	1 0 0	0010-abX0-X	C	LCD 1/2 bias option ab=00: 2 commons option ab=01: 3 commons option ab=10: 4 commons option	
BIAS 1/3	1 0 0	0010-abX1-X	C	LCD 1/3 bias option ab=00: 2 commons option ab=01: 3 commons option ab=10: 4 commons option	
TONE 4K	1 0 0	010X-XXXX-X	C	Tone frequency, 4kHz	
TONE 2K	1 0 0	011X-XXXX-X	C	Tone frequency, 2kHz	
IRQ DIS	1 0 0	100X-0XXX-X	C	Disable IRQ output	Yes
IRQ EN	1 0 0	100X-1XXX-X	C	Enable IRQ output	
F1	1 0 0	101X-X000-X	C	Time base/WDT clock output: 1Hz The WDT time-out flag after: 4s	
F2	1 0 0	101X-X001-X	C	Time base/WDT clock output: 2Hz The WDT time-out flag after: 2s	
F4	1 0 0	101X-X010-X	C	Time base/WDT clock output: 4Hz The WDT time-out flag after: 1s	
F8	1 0 0	101X-X011-X	C	Time base/WDT clock output: 8Hz The WDT time-out flag after: 1/2s	
F16	1 0 0	101X-X100-X	C	Time base/WDT clock output: 16Hz The WDT time-out flag after: 1/4s	
F32	1 0 0	101X-X101-X	C	Time base/WDT clock output: 32Hz The WDT time-out flag after: 1/8s	
F64	1 0 0	101X-X110-X	C	Time base/WDT clock output: 64Hz The WDT time-out flag after: 1/16s	
F128	1 0 0	101X-X111-X	C	Time base/WDT clock output: 128Hz The WDT time-out flag after: 1/32s	Yes
TEST	1 0 0	1110-0000-X	C	Test mode, user don't use.	
NORMAL	1 0 0	1110-0011-X	C	Normal mode	Yes

Note: X: Don't care

A5~A0: RAM addresses

D3~D0: RAM data

D/C: Data/command mode

Def.: Power on reset default

All the bold forms, namely **1 1 0**, **1 0 1** and **1 0 0**, are mode commands. Of these, **1 0 0** indicates the command mode ID. If successive commands have been issued, the command mode ID except for the first command will be omitted. The source of the tone frequency and of the time base/WDT clock frequency can be derived from an on-chip 256kHz RC oscillator, a 32.768kHz crystal oscillator, or an external 256kHz clock. Calculation of the frequency is based on the system frequency sources as stated above. It is recommended that the host controller should initialize the HT1621 after power on reset, for power on reset may fail, which in turn leads to the malfunctioning of the HT1621.

SSOP48L_300mil

TOP VIEW
正视图

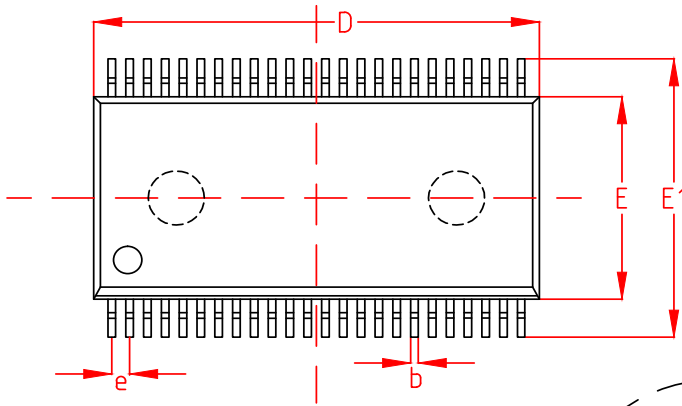

SIDE VIEW
侧视图

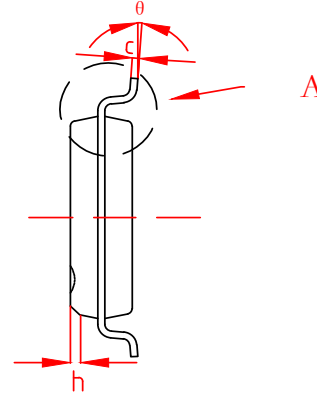

SIDE VIEW
侧视图

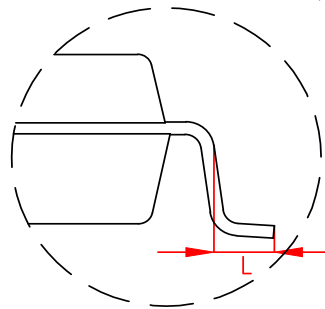
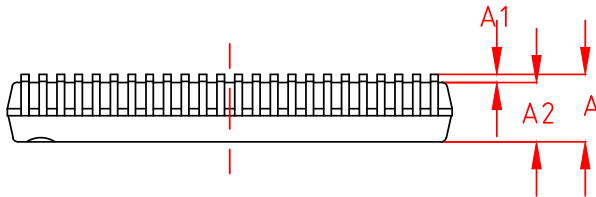

DETAIL
A

机械尺寸/mm Dimensions			
字符 SYMBOL	最小值 MIN	典型值 NOMINAL	最大值 MAX
A	-	-	2.80
A1	0.20	0.30	0.40
A2	2.20	2.30	2.40
b	0.24	-	0.33
c	0.14	-	0.25
D	15.80	15.90	16.00
E	7.40	7.50	7.60
E1	10.10	10.30	10.50
e	0.635 BSC		
L	0.61	-	0.91
h	0.30	-	0.50
θ	0°	-	8°

LQFP48L(7X7X1.4-P0.5)

TOP VIEW
正视图

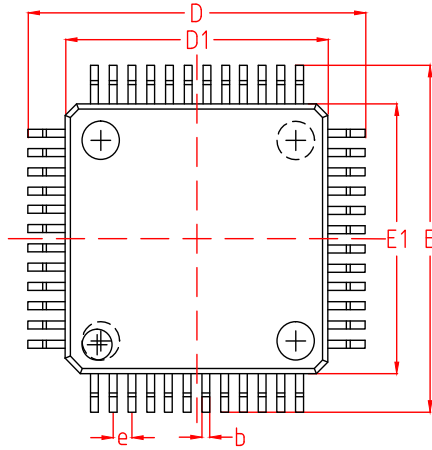

SIDE VIEW
侧视图

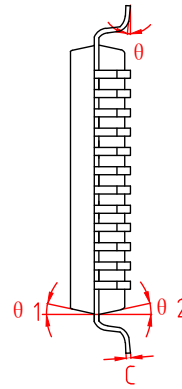

SIDE VIEW
侧视图

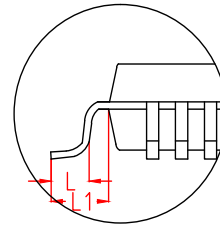
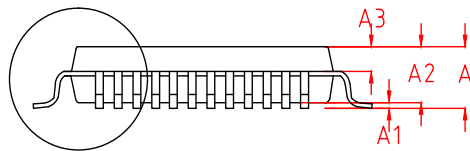

DETAIL:F

机械尺寸/mm Dimensions			
字符 SYMBOL	最小值 MIN	典型值 NOMINAL	最大值 MAX
A	-	-	1.60
A1	0.05	-	0.15
A2	1.35	1.40	1.45
A3	0.59	0.64	0.69
b	0.18	-	0.27
c	0.13	-	0.18
D	8.80	9.00	9.20
D1	6.90	7.00	7.10
E	8.80	9.00	9.20
E1	6.90	7.00	7.10
e	0.50 BSC		
L	0.45	0.60	0.75
L1	1.00REF		
θ	0°	3.5°	7°
θ 1	11°	12°	13°
θ 2	11°	12°	13°

LQFP44L(10X10X1.4-P0.8)

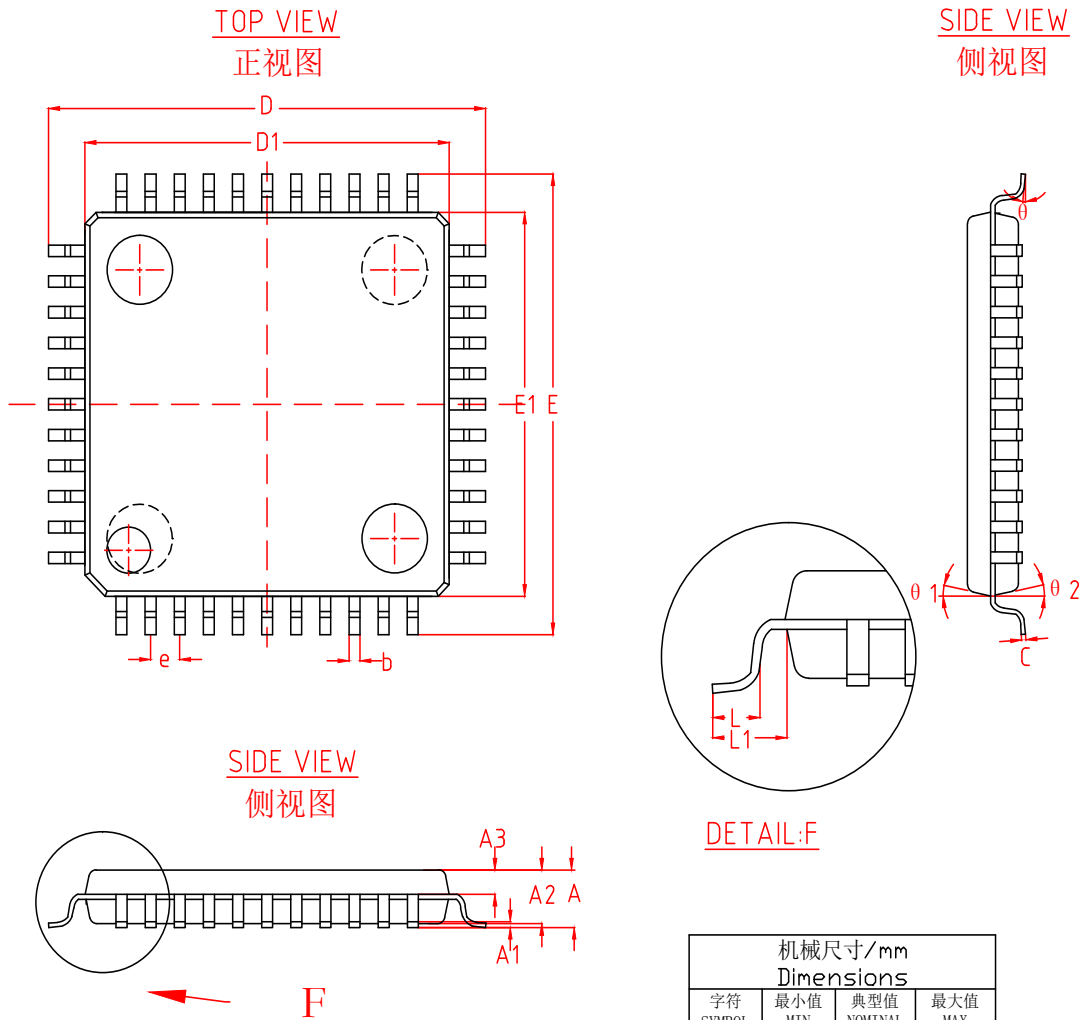

机械尺寸/mm Dimensions			
字符 SYMBOL	最小值 MIN	典型值 NOMINAL	最大值 MAX
A	-	-	1.60
A1	0.05	-	0.15
A2	1.35	1.40	1.45
A3	0.59	0.64	0.69
b	0.28	-	0.36
c	0.13	-	0.17
D	11.80	12.00	12.20
D1	9.90	10.00	10.10
E	11.80	12.00	12.20
E1	9.90	10.00	10.10
e	0.80 BSC		
L	0.45	0.60	0.75
L1	1.00REF		
θ	0°	3.5°	7°
θ 1	11°	12°	13°
θ 2	11°	12°	13°

QFN48L(7x7x0.75-P0.5)

TOP VIEW
正视图

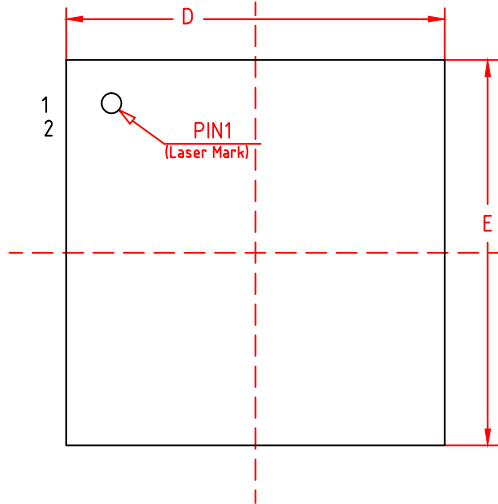

SIDE VIEW
侧视图

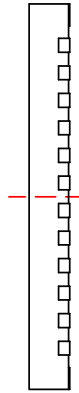

BOTTOM VIEW
背视图

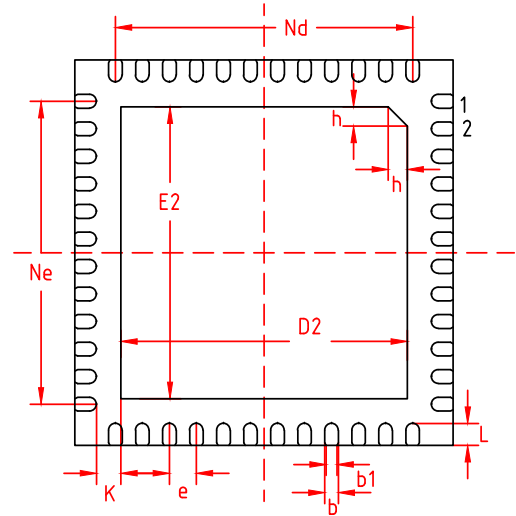

SIDE VIEW
侧视图

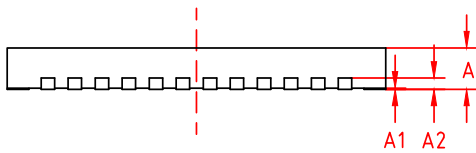

机械尺寸/mm			
字符 SYMBOL	最小值 MIN	典型值 NOMINAL	最大值 MAX
A	0.70	0.75	0.80
A1	-	0.02	0.05
A2	0.203 REF		
b	0.20	0.25	0.30
b1	0.15	0.20	0.25
D	6.90	7.00	7.10
D2	5.20	5.30	5.40
E	6.90	7.00	7.10
E2	5.20	5.30	5.40
e	0.50 BSC		
K	0.35	0.45	0.55
L	0.35	0.40	0.45
h	0.30	0.35	0.40
Ne	5.50 BSC		
Nd	5.50 BSC		

28-pin SKDIP28 (300mil) Outline Dimensions

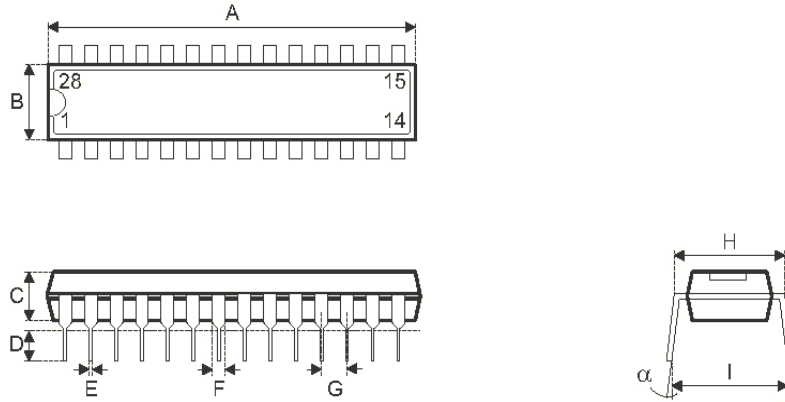

Symbol	Dimensions in mil		
	Min.	Nom.	Max.
A	1375	—	1395
B	278	—	298
C	125	—	135
D	125	—	145
E	16	—	20
F	50	—	70
G	—	100	—
H	295	—	315
I	330	—	375
	0°	—	15°

免责声明核心条款

本规格书所载信息由[深圳市海天芯微电子有限公司]（以下简称“海天芯”）提供，仅作为技术参考文档使用。本公司不对规格书中任何数据的准确性、完整性或适用性作出明示或暗示的保证，包括但不限于：

- 1.更新与终止：本公司保留随时修改、补充或终止本规格书的权利，恕不另行通知。
- 2.设计参数、性能指标及测试结果可能因实际应用环境、制造工艺或第三方组件差异而发生变化。
- 3.文档中引用的第三方技术或专利信息可能存在更新滞后，建议用户自行核实最新状态。
- 4.规格书不构成对产品功能、可靠性或安全性的承诺，实际表现需经用户独立验证。
- 5.因使用本规格书信息导致的直接、间接、特殊或衍生性损失（包括但不限于利润损失、生产中断或数据损坏）。
- 6.用户基于未经验证的设计参数实施工程决策所产生的后果。
- 7.第三方知识产权侵权索赔，除非该侵权由本公司故意行为直接导致。
- 8.在应用本规格书前，自行评估设计可行性并承担全部技术风险。
- 9.不将文档内容用于未经授权的商业目的或侵犯第三方权益。
- 10.发现信息矛盾或缺陷时，立即停止使用并通知本公司。