

74HC04D-HX/74HC04N-HX HEX INVERTERS

Description

The 74HC04D-HX/74HC04N-HX devices incorporate six independent inverters. These gates implement the Boolean function $Y = \bar{A}$ (i.e., logical inversion) in positive logic notation. Encapsulated with SOP-14, DIP-14.

Features

- ★ Wide operating voltage range of 2V to 6V
- ★ Low power consumption, $2\mu\text{Amax. ICC}$
- ★ Typical $t_{PD}=8\text{ns}$
- ★ $\pm 4\text{mA}$ Output drive at 4.5V
- ★ Low input current of 100nA max

PIN CONFIGURATION

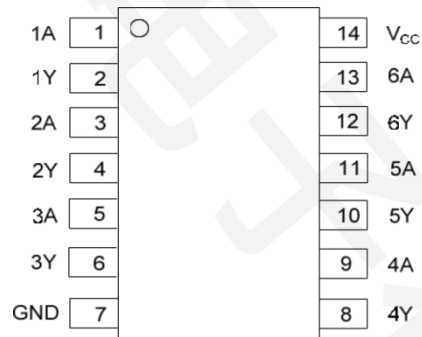

SOP-14 / DIP-14

FUNCTION TABLE (each gate)

INPUT(A)	OUTPUT(Y)
L	H
H	L

LOGIC DIAGRAM (positive logic)

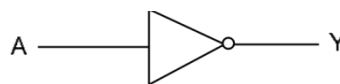

ABSOLUTE MAXIMUM RATING ($T_A = 25^\circ\text{C}$, unless otherwise specified) (Note 2)

PARAMETER	SYMBOL	RATINGS	UNIT
Supply Voltage	V_{CC}	-0.5 ~ 7	V
Input Clamp Current	I_{IK}	± 20	mA
Output Clamp Current	I_{OK}	± 20	mA
Output Current	I_{OUT}	± 25	mA
VCC or GND Current	I_{CC}	± 50	mA
Storage Temperature	T_{STG}	-65 ~ +150	$^\circ\text{C}$

Note: 1. Absolute maximum ratings are those values beyond which the device could be permanently damaged. Absolute maximum ratings are stress ratings only and functional device operation is not implied.

2. The input and output voltage ratings may be exceeded if the input and output current ratings are observed.

THERMAL DATA

PARAMETER	SYMBOL	RATINGS	UNIT
Junction to Ambient	DIP-14	80	$^\circ\text{C}/\text{W}$
	SOP-14U	125	$^\circ\text{C}/\text{W}$

RECOMMENDED OPERATING CONDITIONS ($T_A = 25^\circ\text{C}$, unless otherwise specified)

PARAMETER	SYMBOL	CONDITIONS	MIN	TYP	MAX	UNIT
Supply Voltage	V_{CC}	Operating	2	5	6	V
Input Voltage	V_I	-	0	-	V_{CC}	V
Output Voltage	V_O	-	0	-	V_{CC}	V
Input transition rise/fall time	$\Delta t/\Delta v$	$V_{CC}=2\text{V}$	-	-	1000	ns
		$V_{CC}=4.5\text{V}$	-	-	500	ns
		$V_{CC}=6\text{V}$	-	-	400	ns
Operating Temperature	T_A	-	-40	-	+125	$^\circ\text{C}$

STATIC CHARACTERISTICS ($T_A=25^\circ\text{C}$, unless otherwise specified)

PARAMETER	SYMBOL	TEST CONDITIONS	MIN	TYP	MAX	UNIT
High-Level Input Voltage	V_{IH}	$V_{CC}=2\text{V}$	1.5	-	-	V
		$V_{CC}=4.5\text{V}$	3.15	-	-	V
		$V_{CC}=6\text{V}$	4.2	-	-	V
Low-Level Input Voltage	V_{IL}	$V_{CC}=2\text{V}$	-	-	0.5	V
		$V_{CC}=4.5\text{V}$	-	-	1.35	V
		$V_{CC}=6\text{V}$	-	-	1.8	V
High-Level Output Voltage	V_{OH}	$V_{CC}=2\text{V}, I_{OH}=-20\mu\text{A}$	1.9	1.998	-	V
		$V_{CC}=4.5\text{V}, I_{OH}=-20\mu\text{A}$	4.4	4.499	-	V
		$V_{CC}=6\text{V}, I_{OH}=-20\mu\text{A}$	5.9	5.999	-	V
		$V_{CC}=4.5\text{V}, I_{OH}=-4\text{mA}$	3.98	4.3	-	V
		$V_{CC}=6\text{V}, I_{OH}=-5.2\text{mA}$	5.48	5.8	-	V
Low-Level Output Voltage	V_{OL}	$V_{CC}=2\text{V}, I_{OL}=20\mu\text{A}$	-	0.002	0.1	V
		$V_{CC}=4.5\text{V}, I_{OL}=20\mu\text{A}$	-	0.001	0.1	V
		$V_{CC}=6\text{V}, I_{OL}=20\mu\text{A}$	-	0.001	0.1	V
		$V_{CC}=4.5\text{V}, I_{OL}=4\text{mA}$	-	0.17	0.26	V
		$V_{CC}=6\text{V}, I_{OL}=5.2\text{mA}$	-	0.15	0.26	V
Input Leakage Current	I_I	$V_{CC}=6\text{V}, V_I=V_{CC}$ or GND	-	± 0.1	± 100	nA
Quiescent Supply Current	I_{CC}	$V_{CC}=6\text{V}, V_I=V_{CC}$ or GND $I_O=0$	-	-	2	μA
Input Capacitance	C_I	$V_{CC}=2\text{V}$ to 6V	-	3	10	pF

DYNAMIC CHARACTERISTICS (Input: $t_r, t_f=6\text{ns}$, $C_L=50\text{pF}$; $P_{RR}\leq 1\text{MHz}$) See Fig. 1 and Fig. 2 for test circuit and waveforms.

PARAMETER	SYMBOL	TEST CONDITIONS	MIN	TYP	MAX	UNIT
Propagation delay from input (A) to output(Y)	t_{PLH}/t_{PHL}	$V_{CC}=2\text{V}$	-	45	95	ns
		$V_{CC}=4.5\text{V}$	-	9	19	ns
		$V_{CC}=6\text{V}$	-	8	16	ns
Rise/fall time for output(Y)	t_t	$V_{CC}=2\text{V}$	-	38	75	ns
		$V_{CC}=4.5\text{V}$	-	8	15	ns
		$V_{CC}=6\text{V}$	-	6	13	ns

OPERATING CHARACTERISTICS

PARAMETER	SYMBOL	TEST CONDITIONS	MIN	TYP	MAX	UNIT
Power Dissipation Capacitance	C_{PD}	No Load	-	20	-	pF

TEST CIRCUIT AND WAVEFORMS

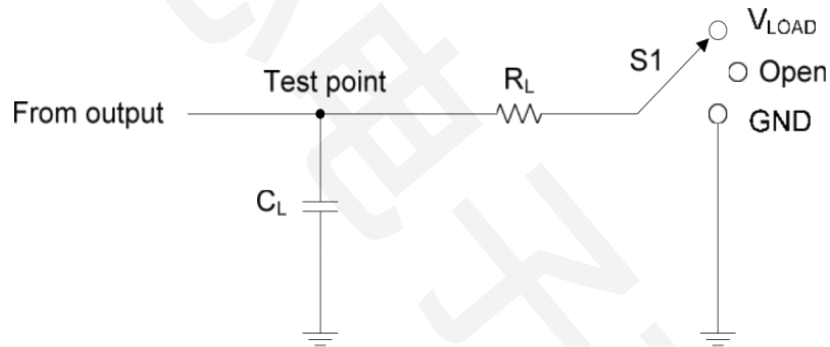

TEST CIRCUIT

TEST	S1
t_{PLH}/t_{PHL}	Open

Inputs		V_M	V_{LOAD}	C_L
V_{IN}	t_r, t_f			
V_{CC}	6 ns	$V_{CC}/2$	V_{CC}	50 pF

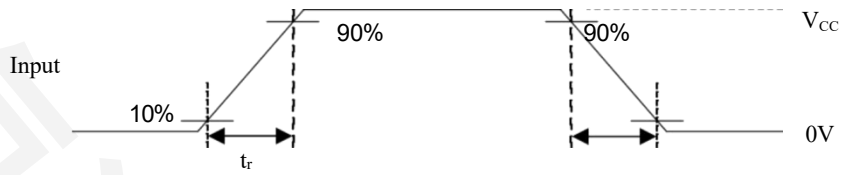

Fig 1. voltage waveforms input rise and fall times

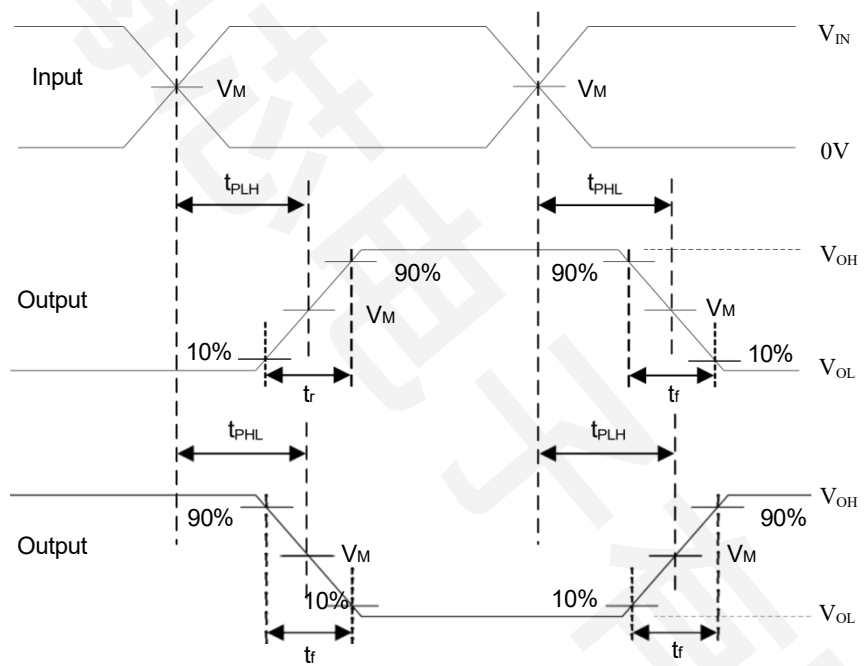
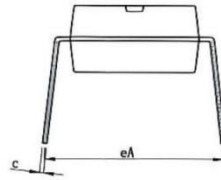
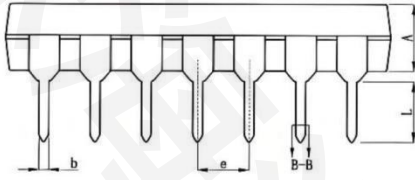

Fig 2. voltage waveforms propagation delay and output transition times

PACKAGE INFORMATION

74HC04N-HX DIP 14 package information



Symbol	Millimeter		
	Min	Nom	Max
A	3.20	3.30	3.40
b	0.44	----	0.53
b1	0.43	0.46	0.49
c	0.25	----	0.30
c1	0.24	0.25	0.26
D	18.95	19.05	19.15
E	6.25	6.35	6.45
e	2.54(BSC)		
eA	7.62	----	9.50
L	3.00	----	----

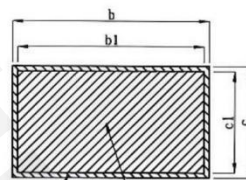
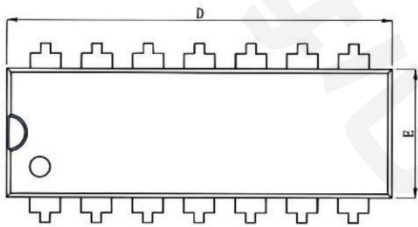

WITH PLATING BASE METAL

SECTION B-B

74HC04D-HX SOP 14 package information

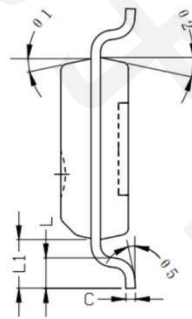
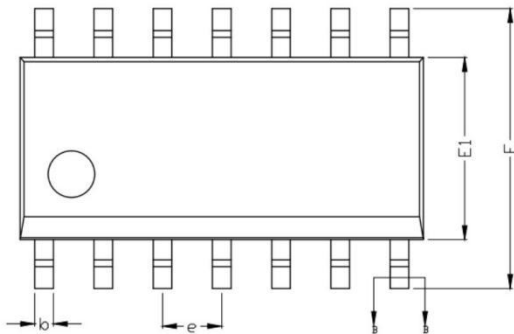

SYMBOL	MILLIMETER		
	MIN	NOM	MAX
A	--	--	1.70
A1	0.10	0.15	0.21
A2	1.40	1.45	1.50
A3	0.60	0.65	0.70
b	0.33	--	0.47
b1	0.32	0.41	0.44
c	0.20	--	0.24
c1	0.19	0.20	0.21
D	8.45	8.60	8.75
E	5.80	6.00	6.20
E1	3.85	3.90	4.00
e	1.27(BSC)		
L	0.50	0.60	0.70
L1	1.10(BSC)		
θ 1	8°	~	15°
θ 2	8°	~	15°
θ 3	8°	~	15°
θ 4	8°	~	15°
θ 5	0°	~	6°

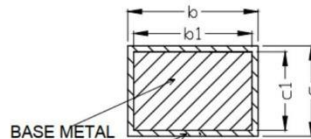
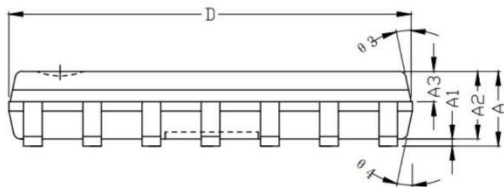

BASE METAL

WITH PLATING

SECTION B-B