

## 74HC125D-HX/74HC125N-HX QUADRUPLE 3-STATE BUFFERS OE LOW

### DESCRIPTION

The 74HC125D-HX/74HC125N-HX is a quad buffer/line driver featuring three-state outputs, each controlled by its respective output-enable input (nOE).

A HIGH logic level applied to nOE places the corresponding output into a high-impedance (OFF) state.

Input terminals incorporate integrated clamp diodes, enabling the use of external current-limiting resistors to safely interface the inputs with signal voltages exceeding  $V_{CC}$ .

### FEATURES

- ★ Input levels: CMOS level
- ★ Specified from -40°C to +125°C
- ★ Packaging information: DIP14 and SOP14

### Pin Configurations

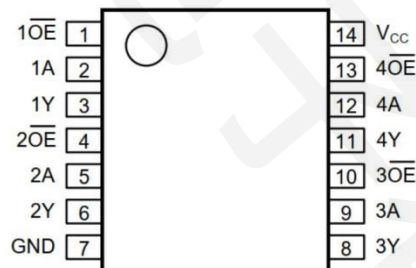

### Pin Description

Pin No.	Pin Name	Description
1	$\overline{1OE}$	output enable input (active LOW)
2	1A	data input
3	1Y	data output
4	$\overline{2OE}$	output enable input (active LOW)
5	2A	data input
6	2Y	data output
7	GND	ground (0V)
8	3Y	data output
9	3A	data input
10	$\overline{3OE}$	output enable input (active LOW)
11	4Y	data output
12	4A	data input
13	$\overline{4OE}$	output enable input (active LOW)
14	VCC	supply voltage

## Function Table

Control	Input	Output
$\overline{nOE}$	nA	nY
L	L	L
L	H	H
H	X	Z

Note: H=HIGH voltage level; L=LOW voltage level; X=don't care; Z=high-impedance OFF-state.

## Block Diagram And Pin Description

### Block Diagram

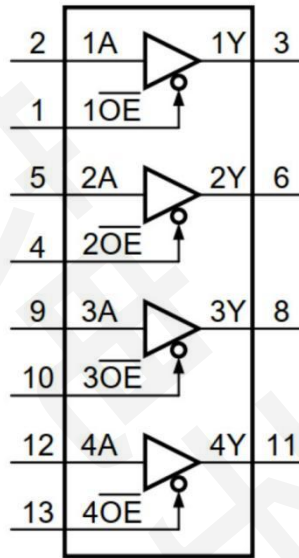

Figure 1. Logic symbol

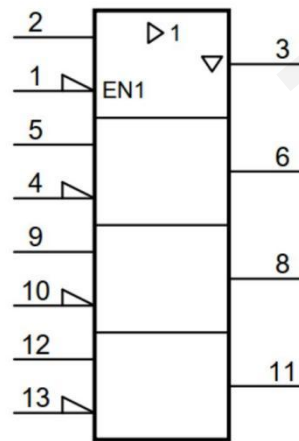

Figure 2. IEC logic symbol

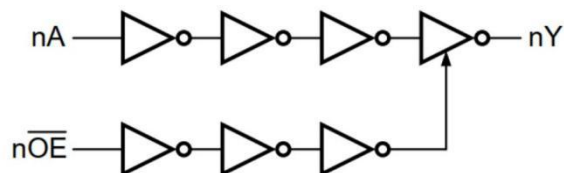

Figure 3. Logic diagram for one gate

## Electrical Parameter

Absolute Maximum Ratings(Voltages are referenced to GND (ground=0V), unless otherwise specified.)

Parameter	Symbol	Conditions	Min.	Max	Unit
supply voltage	$V_{CC}$	-	-0.5	+7	V
input clamping current	$I_{IK}$	$V_I < -0.5V$ or $V_I > V_{CC}+0.5V$	-	$\pm 20$	mA
output clamping current	$I_{OK}$	$V_O < -0.5V$ or $V_O > V_{CC}+0.5V$	-	$\pm 20$	mA
output current	$I_O$	$-0.5V < V_O < V_{CC}+0.5V$	-	$\pm 35$	mA
supply current	$I_{CC}$	-	-	70	mA
ground current	$I_{GND}$	-	-70	-	mA
total power dissipation	$P_{tot}$	-	-	500	mW
storage temperature	$T_{stg}$	-	-65	+150	°C
soldering temperature	$T_L$	10s	DIP	245	°C
			SOP	260	

## Recommended Operating Conditions

Parameter	Symbol	Conditions	Min.	Typ.	Max	Unit
supply voltage	$V_{CC}$	-	2.0	5.0	6.0	V
input voltage	$V_I$	-	0	-	$V_{CC}$	V
output voltage	$V_O$	-	0	-	$V_{CC}$	V
input transition rise and fall rate	$\Delta t/\Delta V$	$V_{CC}=2.0V$	-	-	625	ns/V
		$V_{CC}=4.5V$	-	1.67	139	ns/V
		$V_{CC}=6.0V$	-	-	83	ns/V
ambient temperature	$T_{amb}$	-	-40	-	+125	°C

## Electrical Characteristics

### 5.3.1DC Characteristics 1

T<sub>amb</sub>=25°C, voltages are referenced to GND (ground=0V), unless otherwise specified.

Parameter	Symbol	Conditions	Min.	Typ.	Max.	Unit	
HIGH-level input voltage	V <sub>IH</sub>	V <sub>CC</sub> =2.0V	1.5	1.2	-	V	
		V <sub>CC</sub> =4.5V	3.15	2.4	-	V	
		V <sub>CC</sub> =6.0V	4.2	3.2	-	V	
LOW-level input voltage	V <sub>IL</sub>	V <sub>CC</sub> =2.0V	-	0.8	0.5	V	
		V <sub>CC</sub> =4.5V	-	2.1	1.35	V	
		V <sub>CC</sub> =6.0V	-	2.8	1.8	V	
HIGH-level output voltage	V <sub>OH</sub>	V <sub>I</sub> =V <sub>IH</sub> or V <sub>IL</sub>	I <sub>O</sub> =-20uA; V <sub>CC</sub> =2.0V	1.9	2.0	-	V
			I <sub>O</sub> =-20uA; V <sub>CC</sub> =4.5V	4.4	4.5	-	V
			I <sub>O</sub> =-20uA; V <sub>CC</sub> =6.0V	5.9	6.0	-	V
			I <sub>O</sub> =-6.0mA; V <sub>CC</sub> =4.5V	3.98	4.32	-	V
			I <sub>O</sub> =-7.8mA; V <sub>CC</sub> =6.0V	5.48	5.81	-	V
LOW-level output voltage	V <sub>OL</sub>	V <sub>I</sub> =V <sub>IH</sub> or V <sub>IL</sub>	I <sub>O</sub> =20uA; V <sub>CC</sub> =2.0V	-	0	0.1	V
			I <sub>O</sub> =20uA; V <sub>CC</sub> =4.5V	-	0	0.1	V
			I <sub>O</sub> =20uA; V <sub>CC</sub> =6.0V	-	0	0.1	V
			I <sub>O</sub> =6.0mA; V <sub>CC</sub> =4.5V	-	0.15	0.26	V
			I <sub>O</sub> =7.8mA; V <sub>CC</sub> =6.0V	-	0.16	0.26	V
input leakage current	I <sub>I</sub>	V <sub>I</sub> =V <sub>CC</sub> or GND; V <sub>CC</sub> =6.0V	-	-	±1	uA	
OFF-state output current	I <sub>OZ</sub>	V <sub>I</sub> =V <sub>IH</sub> or V <sub>IL</sub> ; V <sub>O</sub> = V <sub>CC</sub> or GND; V <sub>CC</sub> =6.0V	-	-	±1	uA	
supply current	I <sub>CC</sub>	V <sub>I</sub> =V <sub>CC</sub> or GND; I <sub>O</sub> =0A; V <sub>CC</sub> =6.0V	-	-	8.0	uA	
input capacitance	C <sub>I</sub>	-	-	3.5	-	pF	

## 5.3.2DC Characteristics 2

$T_{amb} = -40^{\circ}\text{C}$  to  $+85^{\circ}\text{C}$ , voltages are referenced to GND (ground=0V), unless otherwise specified.

Parameter	Symbol	Conditions	Min.	Typ.	Max.	Unit	
HIGH-level input voltage	$V_{IH}$	$V_{CC}=2.0V$	1.5	-	-	V	
		$V_{CC}=4.5V$	3.15	-	-	V	
		$V_{CC}=6.0V$	4.2	-	-	V	
LOW-level input voltage	$V_{IL}$	$V_{CC}=2.0V$	-	-	0.5	V	
		$V_{CC}=4.5V$	-	-	1.35	V	
		$V_{CC}=6.0V$	-	-	1.8	V	
HIGH-level output voltage	$V_{OH}$	$V_I = V_{IH}$ or $V_{IL}$	$I_o = -20\mu A; V_{CC} = 2.0V$	1.9	-	-	V
			$I_o = -20\mu A; V_{CC} = 4.5V$	4.4	-	-	V
			$I_o = -20\mu A; V_{CC} = 6.0V$	5.9	-	-	V
			$I_o = -6.0mA; V_{CC} = 4.5V$	3.84	-	-	V
			$I_o = -7.8mA; V_{CC} = 6.0V$	5.34	-	-	V
LOW-level output voltage	$V_{OL}$	$V_I = V_{IH}$ or $V_{IL}$	$I_o = 20\mu A; V_{CC} = 2.0V$	-	-	0.1	V
			$I_o = 20\mu A; V_{CC} = 4.5V$	-	-	0.1	V
			$I_o = 20\mu A; V_{CC} = 6.0V$	-	-	0.1	V
			$I_o = 6.0mA; V_{CC} = 4.5V$	-	-	0.33	V
			$I_o = 7.8mA; V_{CC} = 6.0V$	-	-	0.33	V
input leakage current	$I_I$	$V_I = V_{CC}$ or GND; $V_{CC} = 6.0V$	-	-	$\pm 1$	$\mu A$	
OFF-state output current	$I_{oz}$	$V_I = V_{IH}$ or $V_{IL}; V_o = V_{CC}$ or GND; $V_{CC} = 6.0V$	-	-	$\pm 5$	$\mu A$	
supply current	$I_{cc}$	$V_I = V_{CC}$ or GND; $I_o = 0A$ ; $V_{CC} = 6.0V$	-	-	80	$\mu A$	

## 5.3.3DC Characteristics 3

$T_{amb} = -40^{\circ}\text{C}$  to  $+125^{\circ}\text{C}$ , voltages are referenced to GND (ground=0V), unless otherwise specified.

Parameter	Symbol	Conditions	Min.	Typ.	Max.	Unit	
HIGH-level input voltage	$V_{IH}$	$V_{CC}=2.0V$	1.5	-	-	V	
		$V_{CC}=4.5V$	3.15	-	-	V	
		$V_{CC}=6.0V$	4.2	-	-	V	
LOW-level input voltage	$V_{IL}$	$V_{CC}=2.0V$	-	-	0.5	V	
		$V_{CC}=4.5V$	-	-	1.35	V	
		$V_{CC}=6.0V$	-	-	1.8	V	
HIGH-level output voltage	$V_{OH}$	$V_I = V_{IH}$ or $V_{IL}$	$I_O = -20\mu A; V_{CC} = 2.0V$	1.9	-	-	V
			$I_O = -20\mu A; V_{CC} = 4.5V$	4.4	-	-	V
			$I_O = -20\mu A; V_{CC} = 6.0V$	5.9	-	-	V
			$I_O = -6.0mA; V_{CC} = 4.5V$	3.7	-	-	V
			$I_O = -7.8mA; V_{CC} = 6.0V$	5.2	-	-	V
LOW-level output voltage	$V_{OL}$	$V_I = V_{IH}$ or $V_{IL}$	$I_O = 20\mu A; V_{CC} = 2.0V$	-	-	0.1	V
			$I_O = 20\mu A; V_{CC} = 4.5V$	-	-	0.1	V
			$I_O = 20\mu A; V_{CC} = 6.0V$	-	-	0.1	V
			$I_O = 6.0mA; V_{CC} = 4.5V$	-	-	0.4	V
			$I_O = 7.8mA; V_{CC} = 6.0V$	-	-	0.4	V
input leakage current	$I_I$	$V_I = V_{CC}$ or GND; $V_{CC} = 6.0V$	-	-	$\pm 1$	$\mu A$	
OFF-state output current	$I_{OZ}$	$V_I = V_{IH}$ or $V_{IL}; V_O = V_{CC}$ or GND; $V_{CC} = 6.0V$	-	-	$\pm 10$	$\mu A$	
supply current	$I_{CC}$	$V_I = V_{CC}$ or GND; $I_O = 0A$ ; $V_{CC} = 6.0V$	-	-	160	$\mu A$	

### 3.3.4、AC Characteristics 1

T<sub>amb</sub>=25°C, voltages are referenced to GND (ground=0V), unless otherwise specified.

Parameter	Symbol	Conditions	Min.	Typ.	Max.	Unit	
nA to nY propagation delay	t <sub>pd</sub>	see Figure 5 <sup>[1]</sup>	V <sub>CC</sub> =2.0V	-	30	100	ns
			V <sub>CC</sub> =4.5V	-	11	20	ns
			V <sub>CC</sub> =5.0V; C <sub>L</sub> =15pF	-	9	-	ns
			V <sub>CC</sub> =6.0V	-	9	17	ns
nOE to nY enable time	t <sub>en</sub>	see Figure 6 <sup>[2]</sup>	V <sub>CC</sub> =2.0V	-	41	125	ns
			V <sub>CC</sub> =4.5V	-	15	25	ns
			V <sub>CC</sub> =6.0V	-	12	21	ns
nOE to nY disable time	t <sub>dis</sub>	see Figure 6 <sup>[3]</sup>	V <sub>CC</sub> =2.0V	-	41	125	ns
			V <sub>CC</sub> =4.5V	-	15	25	ns
			V <sub>CC</sub> =6.0V	-	12	21	ns
transition time	t <sub>t</sub>	see Figure 5 <sup>[4]</sup>	V <sub>CC</sub> =2.0V	-	14	60	ns
			V <sub>CC</sub> =4.5V	-	5	12	ns
			V <sub>CC</sub> =6.0V	-	4	10	ns
power dissipation capacitance	C <sub>PD</sub>	C <sub>L</sub> =50pF; f=1MHz; V <sub>I</sub> =GND to V <sub>CC</sub> <sup>[5]</sup>	-	22	-	pF	

Note:

- [1] t<sub>pd</sub> is the same as t<sub>PLH</sub> and t<sub>PHL</sub>.
- [2] t<sub>en</sub> is the same as t<sub>PZL</sub> and t<sub>PZH</sub>.
- [3] t<sub>dis</sub> is the same as t<sub>PLZ</sub> and t<sub>PHZ</sub>.
- [4] t<sub>t</sub> is the same as t<sub>THL</sub> and t<sub>TLH</sub>.
- [5] C<sub>PD</sub> is used to determine the dynamic power dissipation (P<sub>D</sub> in uW).  
 $P_D = (C_{PD} \times V_{CC}^2 \times f_i \times N) + \Sigma(C_L \times V_{CC}^2 \times f_o)$  where:  
 f<sub>i</sub>=input frequency in MHz; f<sub>o</sub>=output frequency in MHz; C<sub>L</sub>=output load capacitance in pF; V<sub>CC</sub>=supply voltage in V;  
 N=number of inputs switching;  
 $\Sigma(C_L \times V_{CC}^2 \times f_o)$ =sum of outputs.

### 3.3.5、AC Characteristics 2

T<sub>amb</sub>=-40°C to +85°C, voltages are referenced to GND (ground=0V), unless otherwise specified.

Parameter	Symbol	Conditions	Min.	Typ.	Max.	Unit	
nA to nY propagation delay	t <sub>pd</sub>	see Figure 5 <sup>[1]</sup>	V <sub>CC</sub> =2.0V	-	-	125	ns
			V <sub>CC</sub> =4.5V	-	-	25	ns
			V <sub>CC</sub> =6.0V	-	-	21	ns
$\overline{\text{nOE}}$ to nY enable time	t <sub>en</sub>	see Figure 6 <sup>[2]</sup>	V <sub>CC</sub> =2.0V	-	-	155	ns
			V <sub>CC</sub> =4.5V	-	-	31	ns
			V <sub>CC</sub> =6.0V	-	-	26	ns
$\overline{\text{nOE}}$ to nY disable time	t <sub>dis</sub>	see Figure 6 <sup>[3]</sup>	V <sub>CC</sub> =2.0V	-	-	155	ns
			V <sub>CC</sub> =4.5V	-	-	31	ns
			V <sub>CC</sub> =6.0V	-	-	26	ns
transition time	t <sub>t</sub>	see Figure 5 <sup>[4]</sup>	V <sub>CC</sub> =2.0V	-	-	75	ns
			V <sub>CC</sub> =4.5V	-	-	15	ns
			V <sub>CC</sub> =6.0V	-	-	13	ns

Note:

- [1] t<sub>pd</sub> is the same as t<sub>PLH</sub> and t<sub>PHL</sub>.
- [2] t<sub>en</sub> is the same as t<sub>PZL</sub> and t<sub>PZH</sub>.
- [3] t<sub>dis</sub> is the same as t<sub>PLZ</sub> and t<sub>PHZ</sub>.
- [4] t<sub>t</sub> is the same as t<sub>THL</sub> and t<sub>TLH</sub>.

### 3.3.6、AC Characteristics 3

T<sub>amb</sub>=-40°C to +125°C, voltages are referenced to GND (ground=0V), unless otherwise specified.

Parameter	Symbol	Conditions	Min.	Typ.	Max.	Unit	
nA to nY propagation delay	t <sub>pd</sub>	see Figure 5 <sup>[1]</sup>	V <sub>CC</sub> =2.0V	-	-	150	ns
			V <sub>CC</sub> =4.5V	-	-	30	ns
			V <sub>CC</sub> =6.0V	-	-	26	ns
$\overline{\text{nOE}}$ to nY enable time	t <sub>en</sub>	see Figure 6 <sup>[2]</sup>	V <sub>CC</sub> =2.0V	-	-	190	ns
			V <sub>CC</sub> =4.5V	-	-	38	ns
			V <sub>CC</sub> =6.0V	-	-	32	ns
$\overline{\text{nOE}}$ to nY disable time	t <sub>dis</sub>	see Figure 6 <sup>[3]</sup>	V <sub>CC</sub> =2.0V	-	-	190	ns
			V <sub>CC</sub> =4.5V	-	-	38	ns
			V <sub>CC</sub> =6.0V	-	-	32	ns
transition time	t <sub>t</sub>	see Figure 5 <sup>[4]</sup>	V <sub>CC</sub> =2.0V	-	-	90	ns
			V <sub>CC</sub> =4.5V	-	-	18	ns
			V <sub>CC</sub> =6.0V	-	-	15	ns

Note:

- [1] t<sub>pd</sub> is the same as t<sub>PLH</sub> and t<sub>PHL</sub>.
- [2] t<sub>en</sub> is the same as t<sub>PZL</sub> and t<sub>PZH</sub>.
- [3] t<sub>dis</sub> is the same as t<sub>PLZ</sub> and t<sub>PHZ</sub>.
- [4] t<sub>t</sub> is the same as t<sub>THL</sub> and t<sub>TLH</sub>.

## Testing Circuit

### 1. AC Testing Circuit

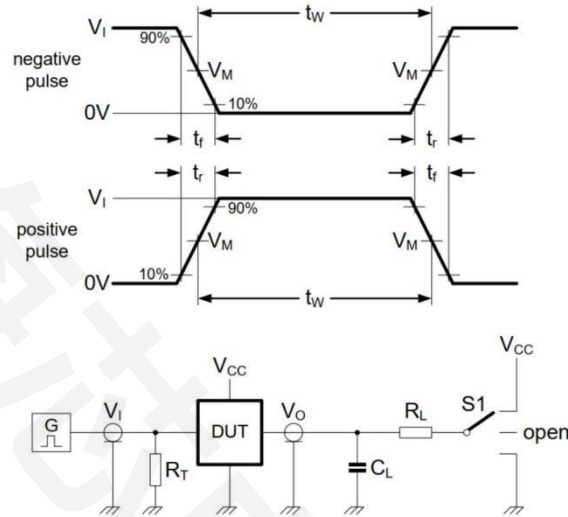

Figure 4. Test circuit for measuring switching times

Definitions for test circuit:

$C_L$  = load capacitance including jig and probe capacitance.

$R_T$  = termination resistance should be equal to the output impedance  $Z_o$  of the pulse generator.  $R_L$  = Load resistance.

$S1$  = Test selection switch.

### 2. AC Testing Waveforms

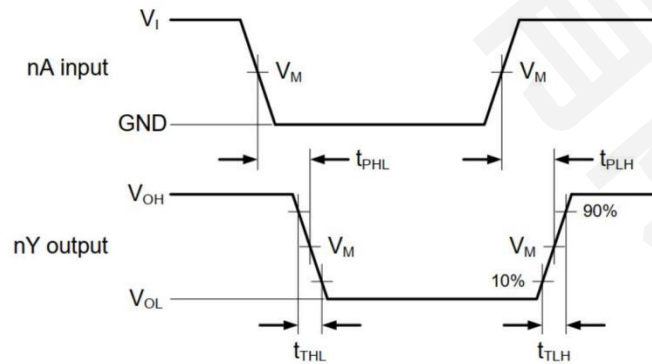

Figure 5. Propagation delay input (nA) to output (nY)

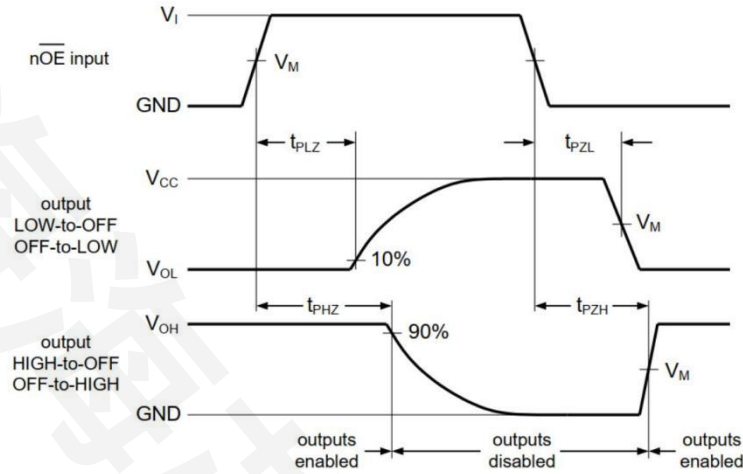

Figure 6. Enable and disable times

### 3. Measurement Points

Type	Input	Output
	$V_M$	$V_M$
74HC125D-HX/74HC125N-HX	$0.5 \times V_{CC}$	$0.5 \times V_{CC}$

### 4. Test Data

Type	Input		Load		S1 position		
	$V_I$	$t_r, t_f$	$C_L$	$R_L$	$t_{PHL}, t_{PLH}$	$t_{PZH}, t_{PHZ}$	$t_{PZL}, t_{PLZ}$
74HC125D-HX 74HC125N-HX	$V_{CC}$	6.0ns	15pF, 50pF	1k $\Omega$	open	GND	$V_{CC}$

### 74HC125N-HX DIP 14 package information

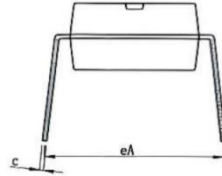
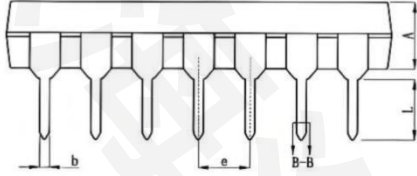

Symbol	Millimeter		
	Min	Nom	Max
A	3.20	3.30	3.40
b	0.44	---	0.53
b1	0.43	0.46	0.49
c	0.25	---	0.30
c1	0.24	0.25	0.26
D	18.95	19.05	19.15
E	6.25	6.35	6.45
e	2.54(BSC)		
eA	7.62	---	9.50
L	3.00	---	---

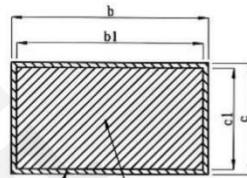
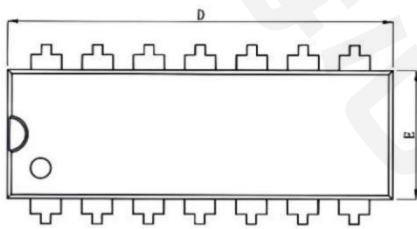

WITH PLATING BASE METAL

SECTION B-B

### 74HC125D-HX SOP 14 package information

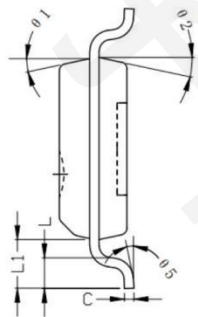
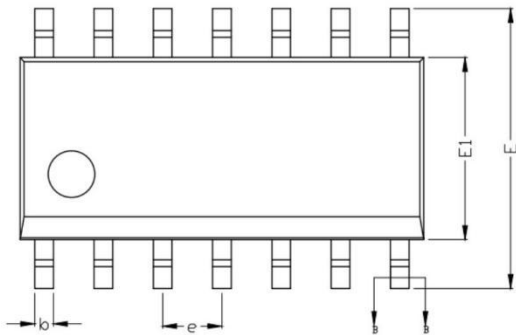

SYMBOL	MILLIMETER		
	MIN	NOM	MAX
A	--	--	1.70
A1	0.10	0.15	0.21
A2	1.40	1.45	1.50
A3	0.60	0.65	0.70
b	0.33	--	0.47
b1	0.32	0.41	0.44
c	0.20	--	0.24
c1	0.19	0.20	0.21
D	8.45	8.60	8.75
E	5.80	6.00	6.20
E1	3.85	3.90	4.00
e	1.27(BSC)		
L	0.50	0.60	0.70
L1	1.10(BSC)		
θ1	8°	~	15°
θ2	8°	~	15°
θ3	8°	~	15°
θ4	8°	~	15°
θ5	0°	~	6°

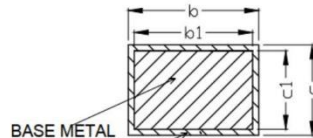
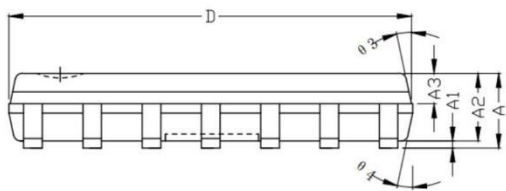

BASE METAL

WITH PLATING  
SECTION B-B