

FEATURES

- Very low leakage current
- Medium speed switching times
- Series pair configuration
- Low leakage switching double diode
- For low leakage current applications

VOLTAGE RANGE

85.0 Volts

CURRENT

0.5 Ampere

JY

SOT-23

1. GATE
2. SOURCE
3. DRAIN

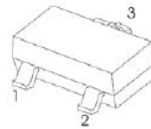

Equivalent Circuit

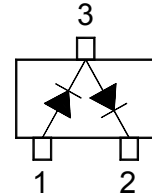

MAXIMUM RATINGS AND ELECTRICAL CHARACTERISTICS

Maximum ratings ($T_a=25^\circ\text{C}$ unless otherwise noted)

Parameter	Symbol	Value	Unit
Peak Repetitive Reverse Voltage	V_{RRM}	85	V
Continuous Reverse Voltage	V_R	85	V
Continuous Forward Current	I_F	160 140	mA
		Single Diode Double Diode	
Repetitive Peak Forward Current	I_{FRM}	500	mA
Non-Repetitive Peak Forward Surge Current	I_{FSM}	4 1 0.5	A
		at $t = 1 \mu\text{s}$ at $t = 1 \text{ms}$ at $t = 1 \text{s}$	
Power Dissipation	P_D	250	mW
Thermal Resistance Junction to Ambient Air	$R_{\theta JA}$	500	$^\circ\text{C/W}$
Operating and Storage Temperature Range	T_j, T_{stg}	- 65 to + 150	$^\circ\text{C}$

Electrical Characteristics

Parameter	Symbol	Min.	Typ.	Max.	Unit
Reverse Breakdown Voltage at $I_R = 100 \mu\text{A}$	$V_{(BR)R}$	85	-	-	V
Forward Voltage at $I_F = 1 \text{ mA}$ at $I_F = 10 \text{ mA}$ at $I_F = 50 \text{ mA}$ at $I_F = 150 \text{ mA}$	V_F	- - - -	- - - -	0.9 1 1.1 1.25	V
Reverse Current at $V_R = 75 \text{ V}$ at $V_R = 75 \text{ V}, T_j = 150 \text{ }^\circ\text{C}$	I_R I_R	- -	- -	5 80	nA
Total Capacitance at $V_R = 0, f = 1 \text{ MHz}$	C_T	-	2	-	pF
Reverse Recovery Time at $I_F = I_R = 10 \text{ mA}, I_{rr} = 0.1 \times I_R, R_L = 100 \Omega$	t_{rr}	-	-	3	μs

RATING AND CHARACTERISTIC CURVES

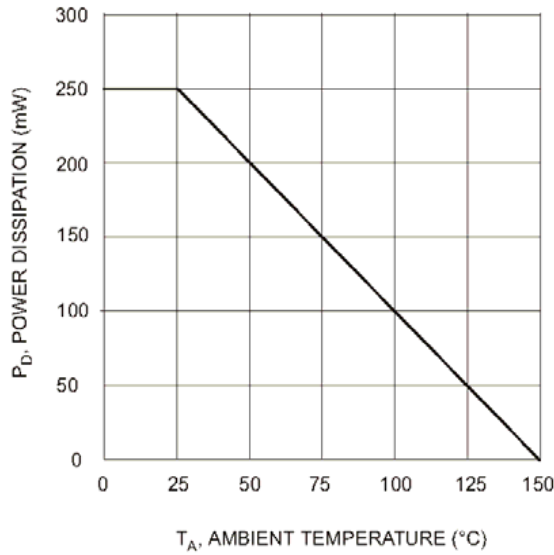

T_A , AMBIENT TEMPERATURE (°C)
Fig. 1 Power Derating Curve

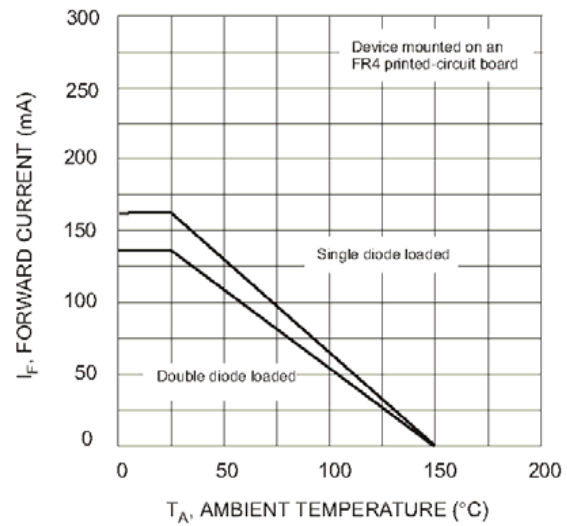

T_A , AMBIENT TEMPERATURE (°C)
Fig. 2 Current Derating Curve

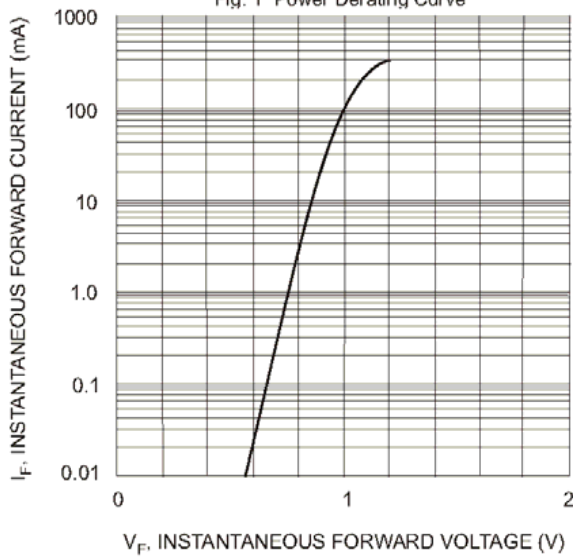

V_F , INSTANTANEOUS FORWARD VOLTAGE (V)
Fig. 3 Typical Forward Characteristics

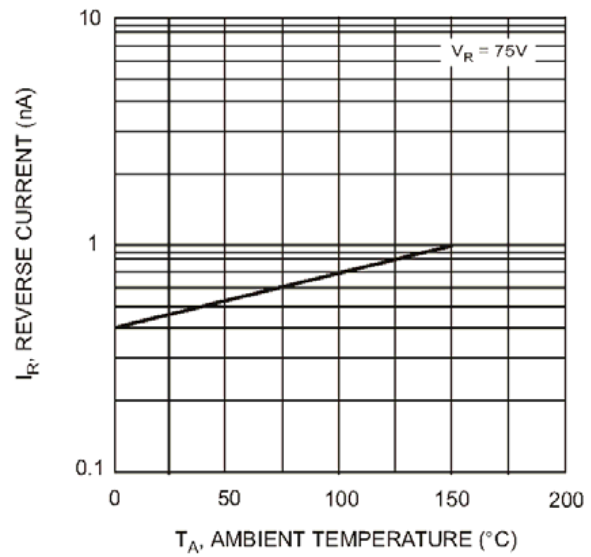

T_A , AMBIENT TEMPERATURE (°C)
Fig. 4 Typical Reverse Characteristics

Soldering parameters

Reflow Condition		Pb-Free assembly (see as below)
Pre Heat	-Temperature Min ($T_{s(min)}$)	+150 °C
	-Temperature Max($T_{s(max)}$)	+200 °C
	-Time (Min to Max) (ts)	60-180 secs.
Average ramp up rate (Liquid us Temp (T_L) to peak)		3 °C/sec. Max
$T_{s(max)}$ to T_L - Ramp-up Rate		3 °C/sec. Max
Reflow	-Temperature(T_L)(Liquid us)	+217 °C
	-Temperature(t_L)	60-150 secs.
Peak Temp (T_P)		+260(+0/-5) °C
Time within 5 °C of actual Peak Temp (t_p)		30 secs. Max
Ramp-down Rate		6 °C/sec. Max
Time 25 °C to Peak Temp (T_P)		8 min. Max
Do not exceed		+260 °C

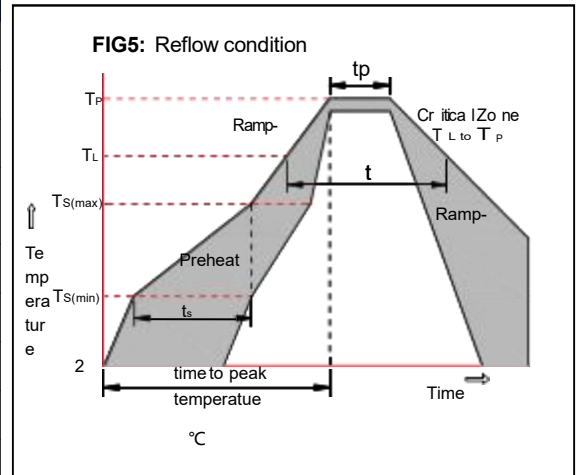

Package Dimensions & Suggested Pad Layout

SOT23

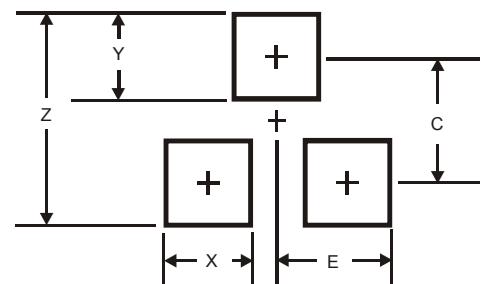
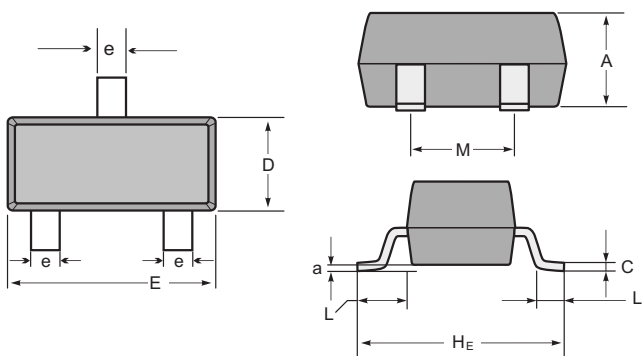

SOT-23 mechanical data

UNIT	A	C	D	E	H _E	e	M	L	L ₁	a	
mm	max	1.1	0.15	1.4	3.0	2.6	0.5	1.95	0.55 (ref)	0.36 (ref)	0.0
	min	0.9	0.08	1.2	2.8	2.2	0.3	1.7			0.15
mil	max	43	6	55	118	102	20	77	22 (ref)	14 (ref)	0.0
	min	35	3	47	110	87	12	67			6

Dimensions	SOT23
Z	2.9
X	0.8
Y	0.9
C	2.0
E	1.35

Tape & reel specification

Tape

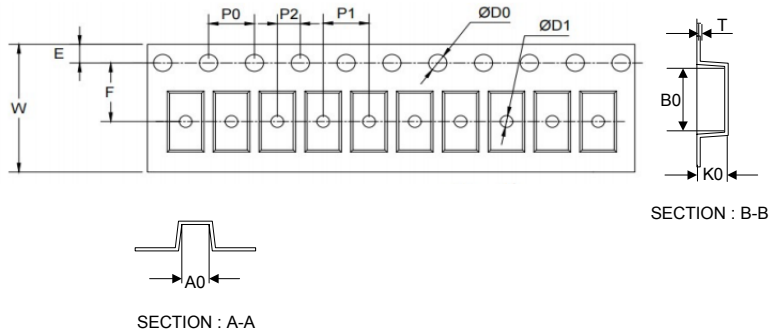

Symbol	Dimension (mm)
P0	4.00±0.10
P1	4.00±0.10
P2	2.00±0.10
D0	1.55±0.10
D1	1.05±0.10
E	1.55±0.10
F	3.60±0.10
W	8.00±0.10
A0	3.80±0.20
B0	3.25±0.20
K0	1.45±0.10
T	0.25±0.05
D2	178.0±3.0
D3	55Min.
D4	R24.0±3.0
G	R82.0±3.0
I	13.0±2.0
W1	11.0±3.0

7" Reel

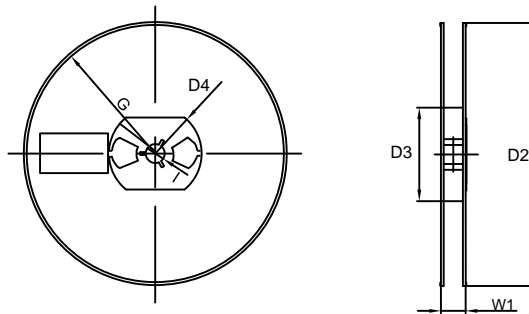

Quantity: 3000PCS