

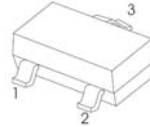

FEATURES

- Complementary to S9014

SOT-23



J6

- 1.BASE
2.EMITTER
3.COLLECTOR

MAXIMUM RATINGS AND ELECTRICAL CHARACTERISTICS

MAXIMUM RATINGS

Rating	Symbol	Value	Unit
Collector–Emitter Voltage	V_{CEO}	45	Vdc
Collector–Base Voltage	V_{CBO}	50	Vdc
Emitter–Base Voltage	V_{EBO}	5.0	Vdc
Collector Current — Continuous	I_c	100	mAdc

THERMAL CHARACTERISTICS

Characteristic	Symbol	Max	Unit
Total Device Dissipation FR– 5 Board, (1) $T_A = 25^\circ\text{C}$	P_D	200	mW
Junction and Storage Temperature	T_J, T_{stg}	- 55 to +150	$^\circ\text{C}$

CLASSIFICATION OF h_{FE}

Rank	L	H
Range	200-450	450-1000

ELECTRICAL CHARACTERISTICS (TA = 25°C unless otherwise noted.)

OFF CHARACTERISTICS

Characteristic	Symbol	Min	Max	Unit
Collector–Emitter Breakdown Voltage(3) ($I_C = 0.1 \text{ mA}_{dc}$, $I_B = 0$)	$V_{(BR)CEO}$	45	—	Vdc
Collector–Base Breakdown Voltage ($I_C = 100 \mu\text{A}_{dc}$, $I_E = 0$)	$V_{(BR)CBO}$	50	—	Vdc
Emitter–Base Breakdown Voltage ($I_E = 100 \mu\text{A}_{dc}$, $I_C = 0$)	$V_{(BR)EBO}$	5.0	—	Vdc
Collector cut-off current ($V_{CB} = 50 \text{ Vdc}$, $I_E = 0$)	I_{CBO}	—	0.1	μA_{dc}
Collector cut-off current ($V_{CE} = 35 \text{ Vdc}$, $I_B = 0$)	I_{CEO}	—	1	μA_{dc}
Emitter cut-off current ($V_{EB} = 3 \text{ Vdc}$, $I_C = 0$)	I_{EBO}	—	0.1	μA_{dc}

- FR-5 = 1.0 x 0.75 x 0.062 in.
- Alumina = 0.4 x 0.3 x 0.024 in. 99.5% alumina.
- Pulse Test: Pulse Width <300 μs , Duty Cycle <2.0%.

ON CHARACTERISTICS

Characteristic	Symbol	Min	Max	Unit
DC Current Gain	h_{FE}			—
($I_C = 1.0 \text{ mA}_{dc}$, $V_{CE} = 5 \text{ Vdc}$)		200	1000	
Collector–Emitter Saturation Voltage	$V_{CE(sat)}$			Vdc
($I_C = 100 \text{ mA}_{dc}$, $I_B = 5 \text{ mA}_{dc}$)(3)		—	0.3	
Base–Emitter Saturation Voltage(3)	$V_{BE(sat)}$			Vdc
($I_C = 100 \text{ mA}_{dc}$, $I_B = 5 \text{ mA}_{dc}$)		—	1.0	

SMALL–SIGNAL CHARACTERISTICS

Current–Gain — Bandwidth Product ($I_C = 10 \text{ mA}_{dc}$, $V_{CE} = 5.0 \text{ Vdc}$, $f = 30 \text{ MHz}$)	f_T	150	—	MHz
--	-------	-----	---	-----

RATING AND CHARACTERISTIC CURVES

Fig.1 Power Derating Curve

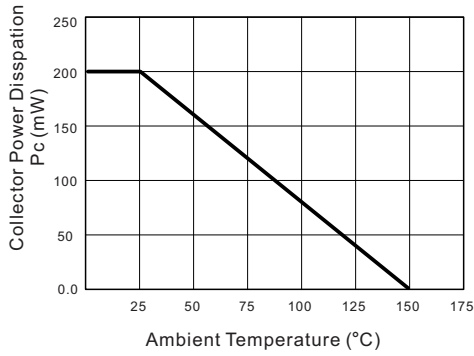

Fig.2 Static characteristics

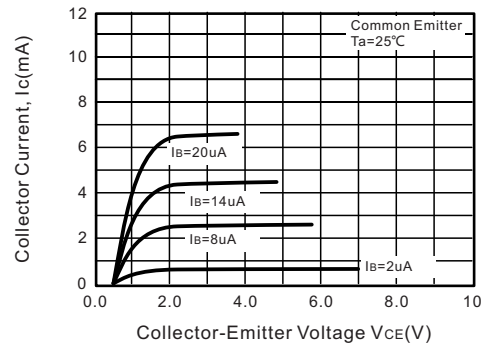

Fig.3 hFE--Ic

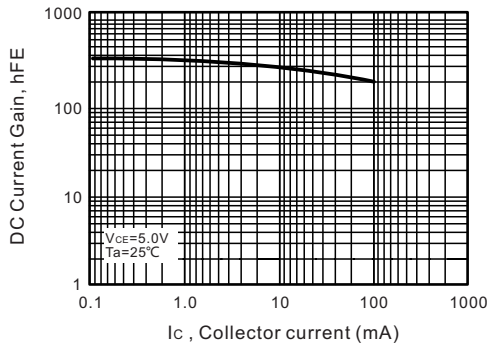

Fig.4 Ic--VBE

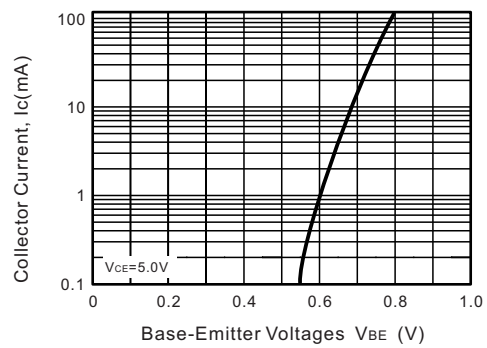

Fig.5 VBEsat--Ic

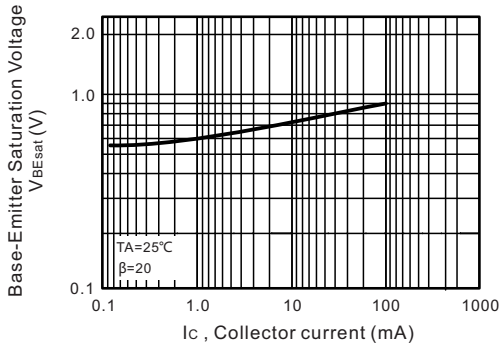

Fig.6 VCEsat--Ic

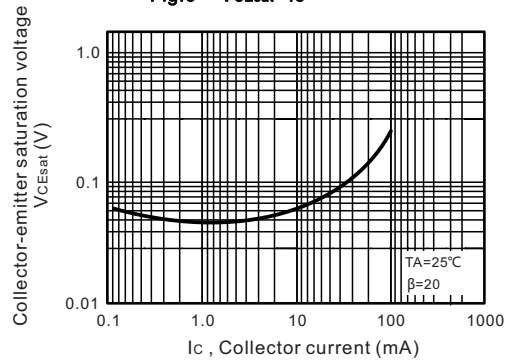

Fig.7 fr--Ic

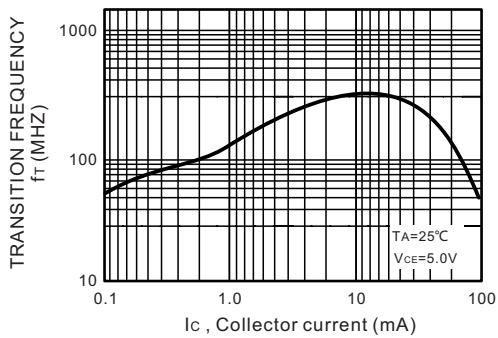
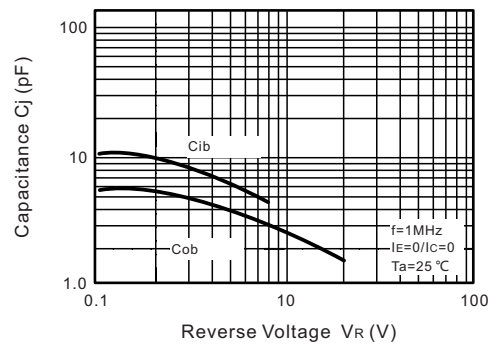
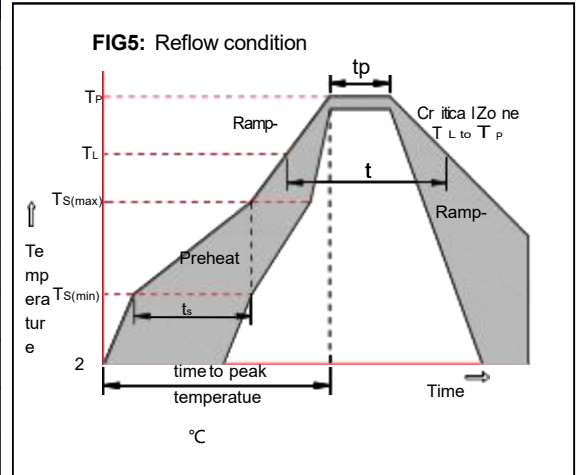

Fig.8 Cob/Cib--Vcb/VEB



Soldering parameters

Reflow Condition		Pb-Free assembly (see as below)
Pre Heat	-Temperature Min ($T_{s(min)}$)	+150°C
	-Temperature Max($T_{s(max)}$)	+200°C
	-Time (Min to Max) (ts)	60-180 secs.
Average ramp up rate (Liquid us Temp (T_L) to peak)		3°C/sec. Max
$T_{s(max)}$ to T_L - Ramp-up Rate		3°C/sec. Max
Reflow	-Temperature(T_L)(Liquid us)	+217°C
	-Temperature(t_L)	60-150 secs.
Peak Temp (T_P)		+260(+0/-5)°C
Time within 5°C of actual Peak Temp (t_p)		30 secs. Max
Ramp-down Rate		6°C/sec. Max
Time 25°C to Peak Temp (T_P)		8 min. Max
Do not exceed		+260°C



Package Dimensions & Suggested Pad Layout

SOT23

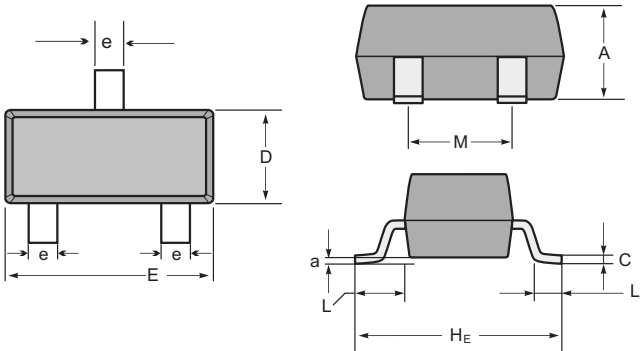

SOT-23 mechanical data

UNIT	A	C	D	E	He	e	M	L	L1	a	
mm	max	1.1	0.15	1.4	3.0	2.6	0.5	1.95	0.55 (ref)	0.36 (ref)	0.0
	min	0.9	0.08	1.2	2.8	2.2	0.3	1.7			0.15
mil	max	43	6	55	118	102	20	77	22 (ref)	14 (ref)	0.0
	min	35	3	47	110	87	12	67			6

Dimensions	SOT23
Z	2.9
X	0.8
Y	0.9
C	2.0
E	1.35

Tape & reel specification

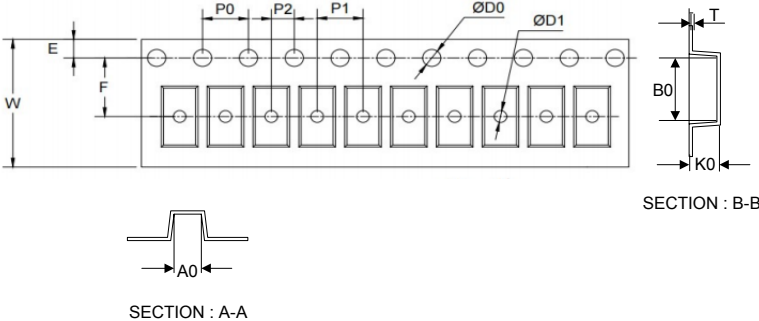
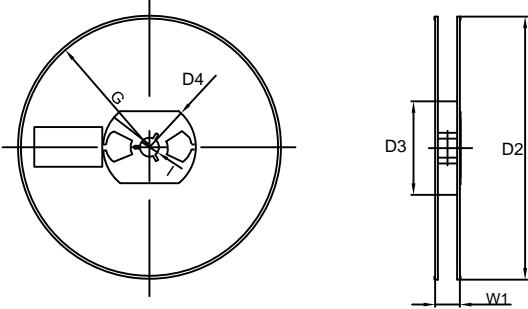
Tape	Symbol	Dimension (mm)	
	P0	4.00±0.10	
	P1	4.00±0.10	
	P2	2.00±0.10	
	D0	1.55±0.10	
	D1	1.05±0.10	
	E	1.55±0.10	
	F	3.60±0.10	
	W	8.00±0.10	
	A0	3.80±0.20	
	B0	3.25±0.20	
	K0	1.45±0.10	
	T	0.25±0.05	
	<p>7" Reel</p> 	D2	178.0±3.0
		D3	55Min.
D4		R24.0±3.0	
G		R82.0±3.0	
I		13.0±2.0	
W1		11.0±3.0	
Quantity: 3000PCS			