

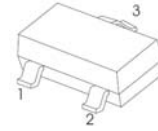

## FEATURES

- Complementary to MMBT3906

SOT-23



1.BASE  
2.EMITTER  
3.COLLECTOR

1AM

## MAXIMUM RATINGS AND ELECTRICAL CHARACTERISTICS

MAXIMUM RATINGS (Ta=25°C unless otherwise noted)

Parameter	Symbol	Value	Unit
Collector–Base Voltage	$V_{CBO}$	60	V
Collector–Emitter Voltage	$V_{CEO}$	40	V
Emitter–Base Voltage	$V_{EBO}$	6	V
Collector Current — Continuous	$I_C$	200	mA
Collector Power Dissipation	$P_C$	200	mW
Thermal Resistance From Junction To Ambient	$R_{thJA}$	625	°C/W
Operation Junction and Storage Temperature Range	$T_J, T_{stg}$	-55~+150	°C

### CLASSIFICATION OF $h_{FE}$

HFE	100-300	
Rank	L	H
Range	100-200	200-300

ELECTRICAL CHARACTERISTICS (TA = 25°C unless otherwise noted.)

Parameter	Symbol	Test conditions	Min	Typ	Max	Unit
Collector-base breakdown voltage	$V_{(BR)CBO}$	$I_C = 10\mu A, I_E = 0$	60			V
Collector-emitter breakdown voltage	$V_{(BR)CEO}$	$I_C = 1\text{ mA}, I_B = 0$	40			V
Emitter-base breakdown voltage	$V_{(BR)EBO}$	$I_E = 10\mu A, I_C = 0$	6			V
Collector cut-off current	$I_{CEX}$	$V_{CE} = 30V, V_{BE(off)} = 3V$			50	nA
Collector cut-off current	$I_{CBO}$	$V_{CB} = 60V, I_E = 0$			100	nA
Emitter cut-off current	$I_{EBO}$	$V_{EB} = 5V, I_C = 0$			100	nA
DC current gain	$h_{FE1}$	$V_{CE} = 1V, I_C = 10mA$	100		300	
	$h_{FE2}$	$V_{CE} = 1V, I_C = 50mA$	60			
	$h_{FE3}$	$V_{CE} = 1V, I_C = 100mA$	30			
Collector-emitter saturation voltage	$V_{CE(sat)}$	$I_C = 50mA, I_B = 5mA$			0.3	V
Base-emitter saturation voltage	$V_{BE(sat)}$	$I_C = 50mA, I_B = 5mA$			0.95	V
Transition frequency	$f_T$	$V_{CE} = 20V, I_C = 10mA, f = 100MHz$	300			MHZ
Delay time	$t_d$	$V_{CC} = 3V, V_{BE(off)} = -0.5V, I_C = 10mA, I_{B1} = 1mA$			35	ns
Rise time	$t_r$				35	ns
Storage time	$t_s$	$V_{CC} = 3V, I_C = 10mA$			200	ns
Fall time	$t_f$	$I_{B1} = I_{B2} = 1mA$			50	ns

**RATING AND CHARACTERISTIC CURVES**

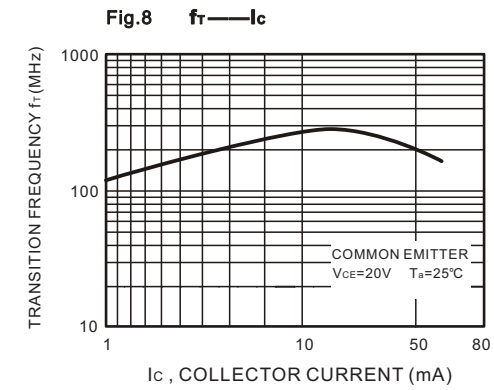
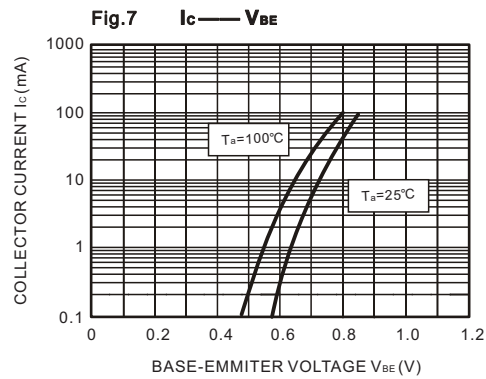
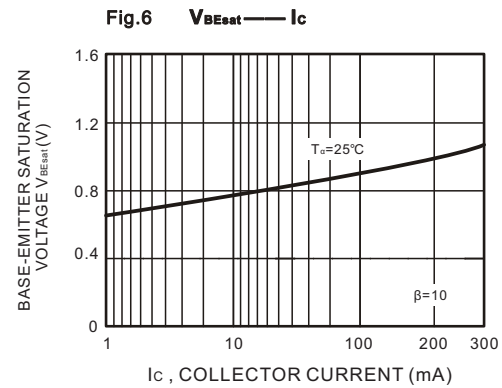
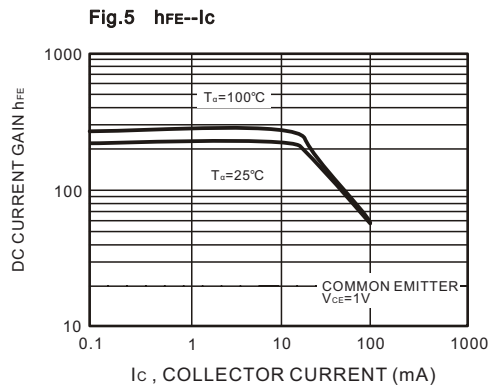
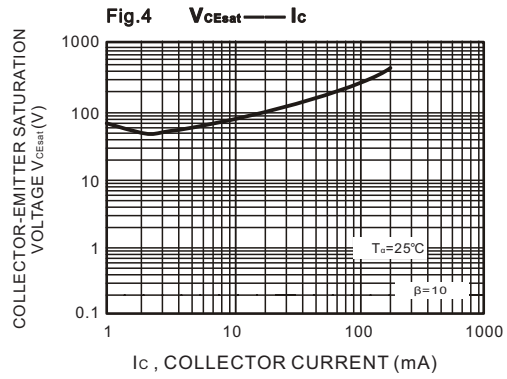
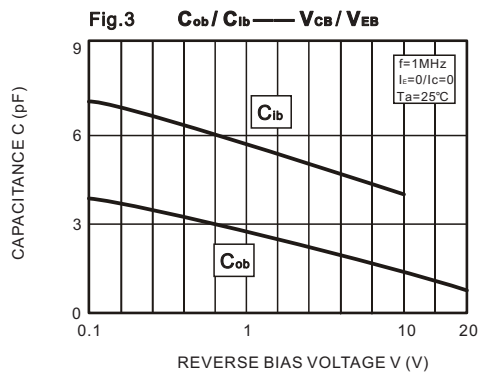
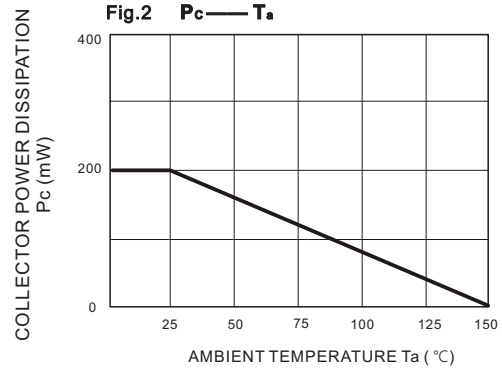
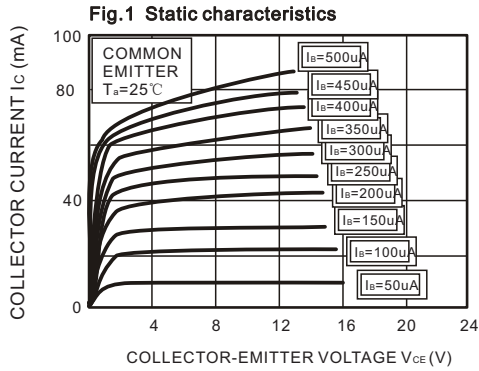

Soldering parameters

Reflow Condition		Pb-Free assembly (see as below)
Pre Heat	-Temperature Min ( $T_{s(min)}$ )	+150°C
	-Temperature Max( $T_{s(max)}$ )	+200°C
	-Time (Min to Max) (ts)	60-180 secs.
Average ramp up rate (Liquid us Temp ( $T_L$ ) to peak)		3°C/sec. Max
$T_{s(max)}$ to $T_L$ - Ramp-up Rate		3°C/sec. Max
Reflow	-Temperature( $T_L$ )(Liquid us)	+217°C
	-Temperature( $t_L$ )	60-150 secs.
Peak Temp ( $T_P$ )		+260(+0/-5)°C
Time within 5°C of actual Peak Temp ( $t_p$ )		30 secs. Max
Ramp-down Rate		6°C/sec. Max
Time 25°C to Peak Temp ( $T_P$ )		8 min. Max
Do not exceed		+260°C

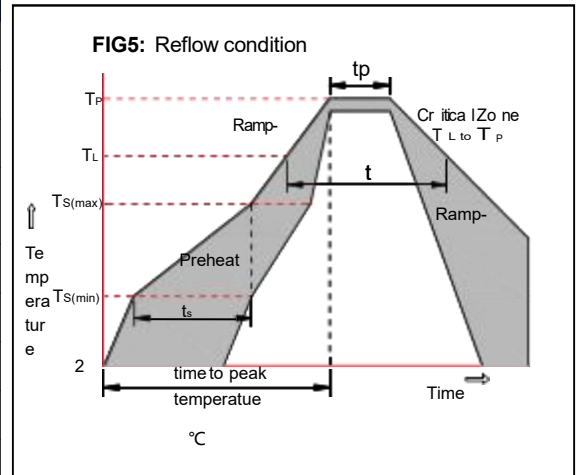

Package Dimensions & Suggested Pad Layout

SOT23

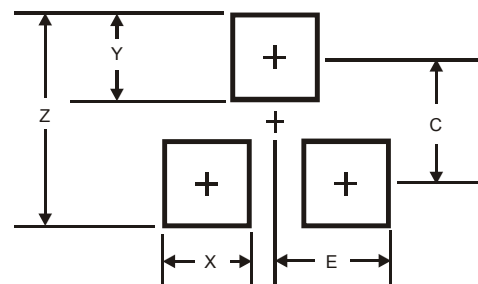
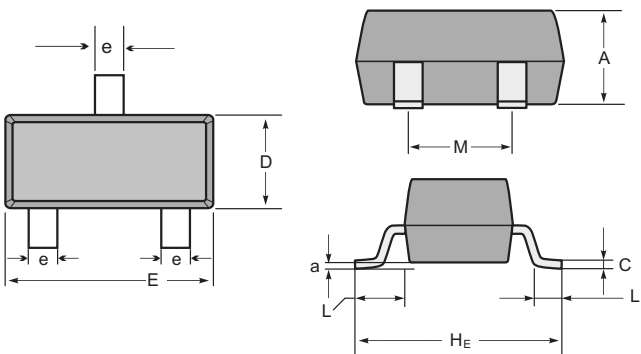

SOT-23 mechanical data

UNIT	A	C	D	E	He	e	M	L	L <sub>1</sub>	a	
mm	max	1.1	0.15	1.4	3.0	2.6	0.5	1.95	0.55 (ref)	0.36 (ref)	0.0
	min	0.9	0.08	1.2	2.8	2.2	0.3	1.7			0.15
mil	max	43	6	55	118	102	20	77	22 (ref)	14 (ref)	0.0
	min	35	3	47	110	87	12	67			6

Dimensions	SOT23
Z	2.9
X	0.8
Y	0.9
C	2.0
E	1.35

Tape & reel specification

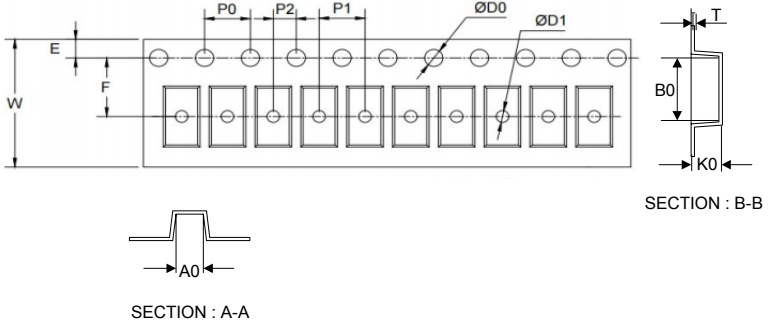
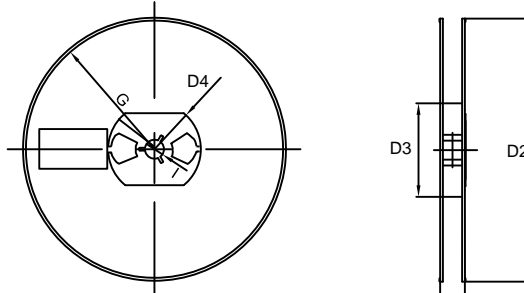
Tape	Symbol	Dimension (mm)
	P0	4.00±0.10
	P1	4.00±0.10
	P2	2.00±0.10
	D0	1.55±0.10
	D1	1.05±0.10
	E	1.55±0.10
	F	3.60±0.10
	W	8.00±0.10
	A0	3.80±0.20
	B0	3.25±0.20
K0	1.45±0.10	
T	0.25±0.05	
<p>7" Reel</p> 	D2	178.0±3.0
	D3	55Min.
	D4	R24.0±3.0
	G	R82.0±3.0
	I	13.0±2.0
	W1	11.0±3.0
	Quantity: 3000PCS	