



FEATURES

- For general AF applications
- Low collector-emitter saturation voltage
- Complementary types: BC817 (NPN)

Classification of hFE

Type	BC817-16	BC817-25	BC817-40
Range	100-250	160-400	250-630
Marking	6A	6B	6C

SOT-23

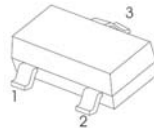

1.BASE
2.EMITTER
3.COLLECTOR

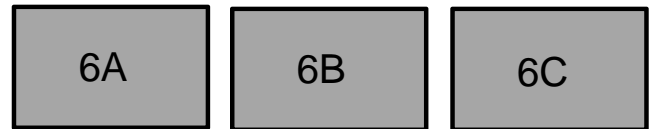

MAXIMUM RATINGS AND ELECTRICAL CHARACTERISTICS

Absolute Maximum Ratings Ta = 25°C

Parameter	Symbol	Rating	Unit
Collector - Base Voltage	V _{CB0}	50	V
Collector - Emitter Voltage	V _{CE0}	45	
Emitter - Base Voltage	V _{EB0}	5	
Collector Current - Continuous	I _C	0.5	A
Collector Power Dissipation	P _C	0.3	W
Junction Temperature	T _J	150	°C
Storage Temperature Range	T _{stg}	-55 to 150	

Characteristics ($T_a = 25^\circ\text{C}$)

Parameter	Symbol	Test Conditions	Min	Typ	Max	Unit
Collector- base breakdown voltage	V_{CBO}	$I_C = 100 \mu\text{A}, I_E = 0$	50			V
Collector- emitter breakdown voltage	V_{CEO}	$I_C = 10 \text{ mA}, I_B = 0$	45			
Emitter - base breakdown voltage	V_{EBO}	$I_E = 100 \mu\text{A}, I_C = 0$	5			
Collector-base cut-off current	I_{CBO}	$V_{CB} = 45 \text{ V}, I_E = 0$			0.1	uA
Emitter cut-off current	I_{EBO}	$V_{EB} = 4 \text{ V}, I_C = 0$			0.1	
Collector-emitter saturation voltage	$V_{CE(sat)}$	$I_C = 500 \text{ mA}, I_B = 50 \text{ mA}$			0.7	V
Base - emitter saturation voltage	$V_{BE(sat)}$	$I_C = 500 \text{ mA}, I_B = 50 \text{ mA}$			1.2	
Base - emitter voltage	V_{BE}	$V_{CE} = 1 \text{ V}, I_C = 500 \text{ mA}$			1.2	
DC current gain	$h_{FE(1)}$	$V_{CE} = 1 \text{ V}, I_C = 100 \text{ mA}$	100		630	
	$h_{FE(2)}$	$V_{CE} = 1 \text{ V}, I_C = 500 \text{ mA}$	40			
Collector output capacitance	C_{ob}	$V_{CB} = 10 \text{ V}, f = 1 \text{ MHz}$		10		pF
Transition frequency	f_T	$V_{CE} = 5 \text{ V}, I_C = 10 \text{ mA}, f = 100 \text{ MHz}$	100			MHz

Classification of $h_{FE(1)}$

Type	BC817-16	BC817-25	BC817-40
Range	100-250	160-400	250-630
Marking	6A	6B	6C

RATING AND CHARACTERISTIC CURVES

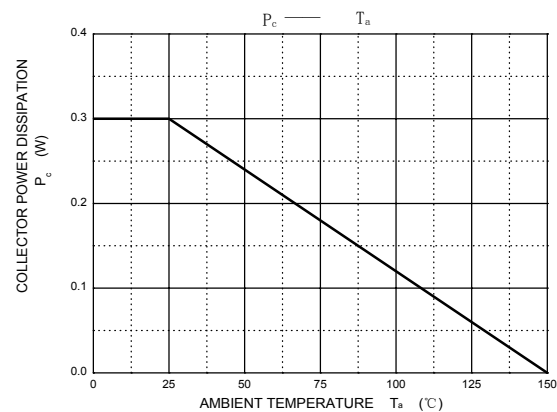
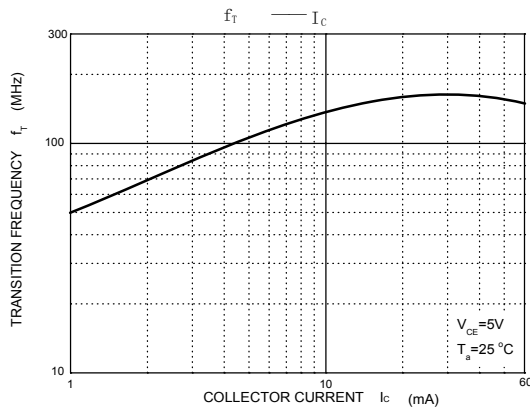
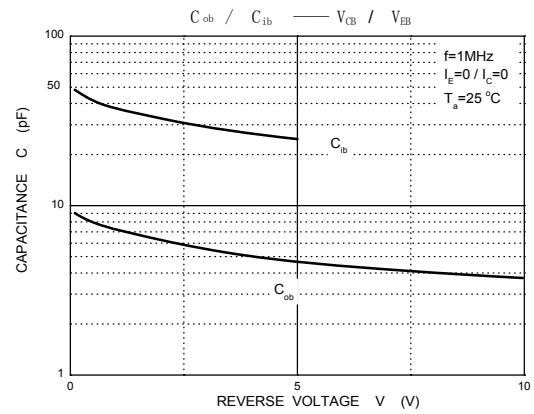
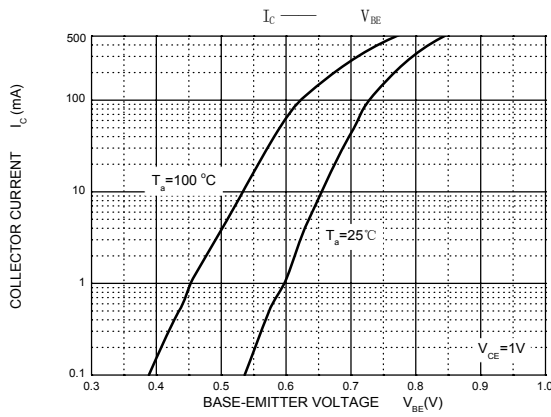
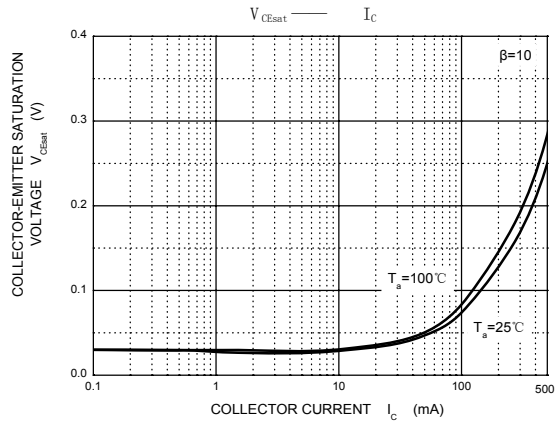
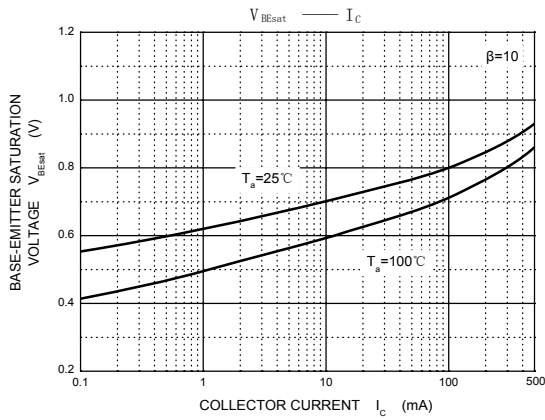
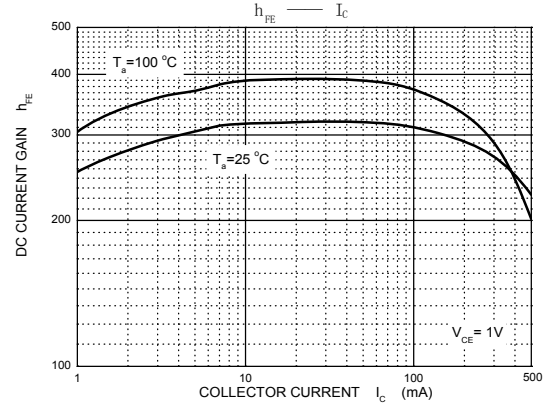
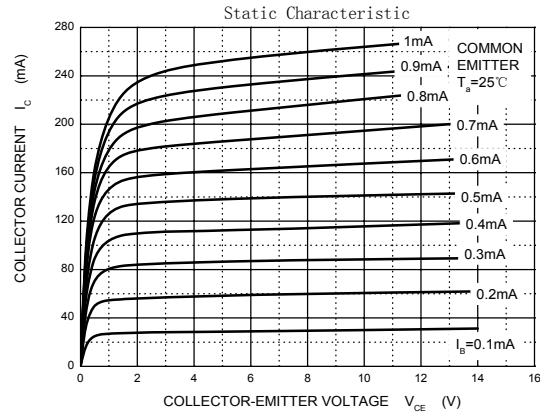

Soldering parameters

Reflow Condition		Pb-Free assembly (see as below)
Pre Heat	-Temperature Min ($T_{s(min)}$)	+150°C
	-Temperature Max($T_{s(max)}$)	+200°C
	-Time (Min to Max) (ts)	60-180 secs.
Average ramp up rate (Liquid us Temp (T_L) to peak)		3°C/sec. Max
$T_{s(max)}$ to T_L - Ramp-up Rate		3°C/sec. Max
Reflow	-Temperature(T_L)(Liquid us)	+217°C
	-Temperature(t_L)	60-150 secs.
Peak Temp (T_P)		+260(+0/-5)°C
Time within 5°C of actual Peak Temp (t_p)		30 secs. Max
Ramp-down Rate		6°C/sec. Max
Time 25°C to Peak Temp (T_P)		8 min. Max
Do not exceed		+260°C



Package Dimensions & Suggested Pad Layout

SOT23

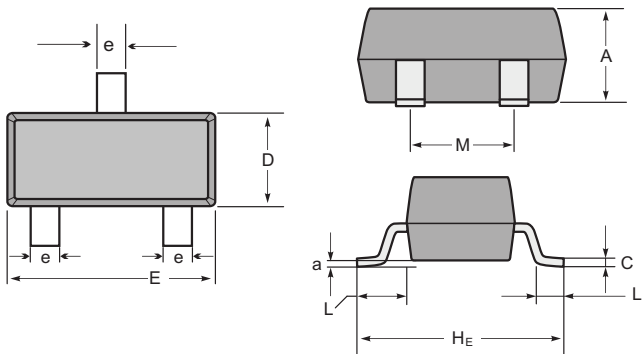

SOT-23 mechanical data

UNIT	A	C	D	E	He	e	M	L	L ₁	a	
mm	max	1.1	0.15	1.4	3.0	2.6	0.5	1.95	0.55 (ref)	0.36 (ref)	0.0
	min	0.9	0.08	1.2	2.8	2.2	0.3	1.7			0.15
mil	max	43	6	55	118	102	20	77	22 (ref)	14 (ref)	0.0
	min	35	3	47	110	87	12	67			6

Dimensions	SOT23
Z	2.9
X	0.8
Y	0.9
C	2.0
E	1.35

Tape & reel specification

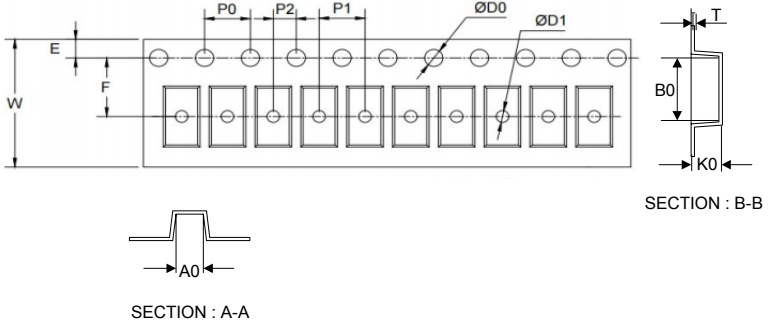
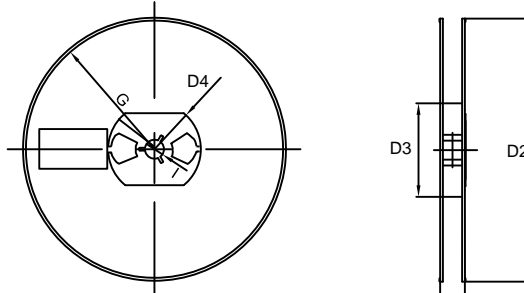
Tape	Symbol	Dimension (mm)	
	P0	4.00±0.10	
	P1	4.00±0.10	
	P2	2.00±0.10	
	D0	1.55±0.10	
	D1	1.05±0.10	
	E	1.55±0.10	
	F	3.60±0.10	
	W	8.00±0.10	
	A0	3.80±0.20	
	B0	3.25±0.20	
	K0	1.45±0.10	
	T	0.25±0.05	
	<p>7" Reel</p> 	D2	178.0±3.0
		D3	55Min.
		D4	R24.0±3.0
G		R82.0±3.0	
I		13.0±2.0	
W1		11.0±3.0	
Quantity: 3000PCS			