

芯伯乐®  
X I N B O L E

# Product Specification

XBLW MC33078DR2G

Dual operational amplifier

WEB | [www.xinboleic.com](http://www.xinboleic.com)



## Descriptions

The MC33078DR2G is a dual operational amplifier IC designed for improved tone control and is well suited for audio applications. Its noise-free, high gain bandwidth, high output current, and low distortion ratio make it suitable not only for acoustic electronic components of audio preamplifiers and active filters, but also for industrial measurement tools. It is also suitable for headphone amplifiers with high output currents, and can be applied to general purpose portable integrated power amplifiers to appropriately bias input low voltage sources in low voltage single supply applications.

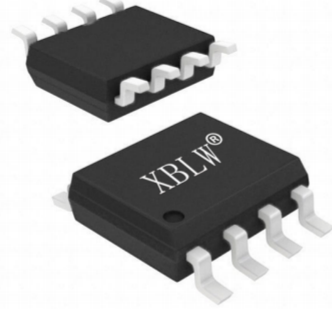

SOP-8

## Feature

- Operating voltage( $\pm 2V \sim \pm 18V$ )
- Low input noise voltage (Typical value  $0.8\mu V_{rms}$ )
- Wide gain bandwidth product (Typical value  $15MHz$ )
- Low distortion (Typical value  $0.0005\%$ )
- Rate of conversion (Typical value  $5V/\mu s$ )
- Bipolar technique

## Applications

- Audio Preamplifiers
- Active Filters
- Headphone Amplifiers
- Industrial Measurement Equipment

## Ordering Information

Product Model	Package Type	Marking	Packing	Packing Qty
XBLW MC33078DR2G	SOP-8	33078	Tape	2500Pcs/Reel

## Internal Block Diagram ( 1/2 )

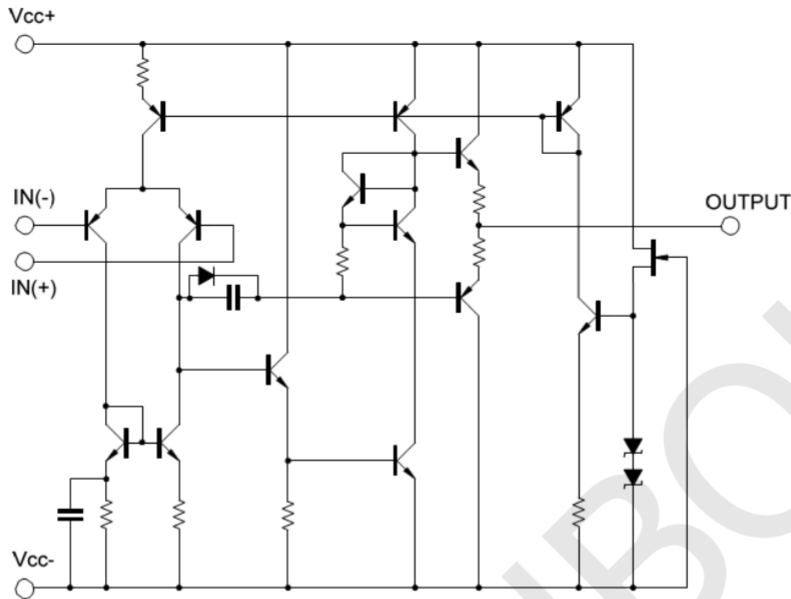

## Pin Configurations

**DIP-8/SOP-8**  
(Top View)

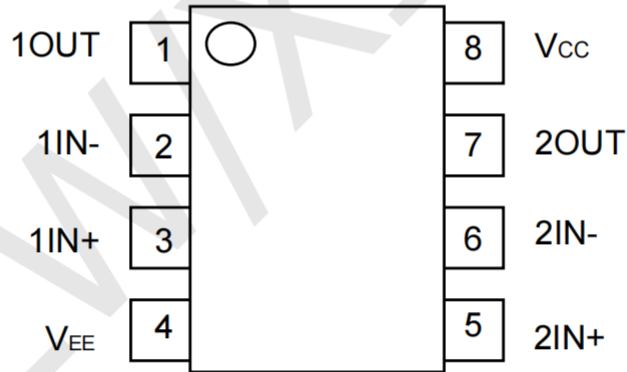

## Pin Description

Pin	Symbol	I/O	Pin Description
1	1OUT	O	Output
2	1IN-	I	Inverting input
3	1IN+	I	Noninverting input
4	V <sub>EE</sub>	—	Negative supply
5	2IN+	I	Noninverting input
6	2IN-	I	Inverting input
7	2OUT	O	Output
8	V <sub>CC</sub>	—	Positive supply

## Absolute Maximum Ratings

( $T_A=25^\circ\text{C}$ , not otherwise specified.)

Parameters	Symbol	Scope of scope	Unit of work
Supply voltage	$V_{CC}/V_{EE}$	$\pm 18$	V
Input voltage	$V_{in}$	$\pm 15$	V
Differential input voltage	$V_{I(DIFF)}$	$\pm 30$	V
Current of output	$I_{OUT}$	$\pm 50$	mA
Power consumption	DIP-8	750	mV
	SOP-8	440	
Temperature of junction	$T_J$	125	$^\circ\text{C}$
Operating temperature	$T_{OPR}$	$-40 \sim +85$	$^\circ\text{C}$
Temperature of storage	$T_{STG}$	$-40 \sim +125$	$^\circ\text{C}$

Note: Exceeding the limit parameters listed may lead to permanent damage inside the chip, and long-term operation under the limit conditions will affect the reliability of the chip.

## DC Electrical Characteristics

( $V_+ / V_- = \pm 15\text{V}$ ,  $T_A=25^\circ\text{C}$ , Unless otherwise stated.)

Parameters	Symbol	Condition of test	Min	Typ	Max	Unit
Input bias voltage	$V_{I(OFF)}$	$R_S \leq 10\text{k}\Omega$		0.5	3	mV
Input bias voltage	$I_{I(OFF)}$			5	200	nA
Input bias current	$I_{I(BIAS)}$			100	500	nA
Large signal voltage gain	$G_v$	$V_{OUT} = \pm 10\text{V}$ , $R_L \geq 2\text{k}\Omega$	90	110		dB
Output voltage swing	$V_{OM}$	$R_L \geq 2\text{k}\Omega$	$\pm 12$	$\pm 13.5$		V
Input the common mode voltage	$V_{I(CM)}$		$\pm 12$	$\pm 13.5$		V
Common mode inhibition ratio	CMRR	$R_S \leq 10\text{k}\Omega$	80	110		dB
Supply voltage rejection ratio	SVR	$R_S \leq 10\text{k}\Omega$	80	110		dB
Current of operation	$I_{CC}$			6	9	mA
Rate of conversion	SR	$R_L \geq 2\text{k}\Omega$		5		V/ $\mu\text{s}$
Gain bandwidth product	GB	$f = 10\text{kHz}$		15		MHz
Total harmonic distortion	THD	$G_v = 20\text{dB}$ , $V_{OUT} = 5\text{V}$ , $R_L = 2\text{k}\Omega$ , $f = 1\text{kHz}$		0.0005		%
Input noise voltage	eN	$R_{IAA}$ $R_S = 2.2\text{ k}\Omega$ , 30kHz LPF		0.8		$\mu\text{Vrms}$
Equivalent Input Noise Voltage 2	eN	$f = 1\text{kHz}$		5		nV/ Hz

**Typical characteristics**

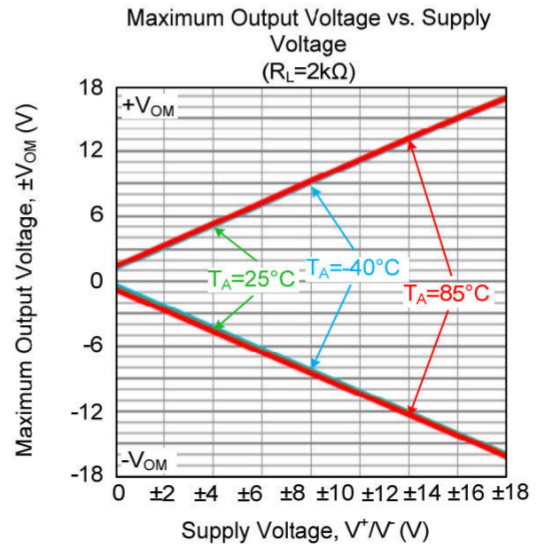
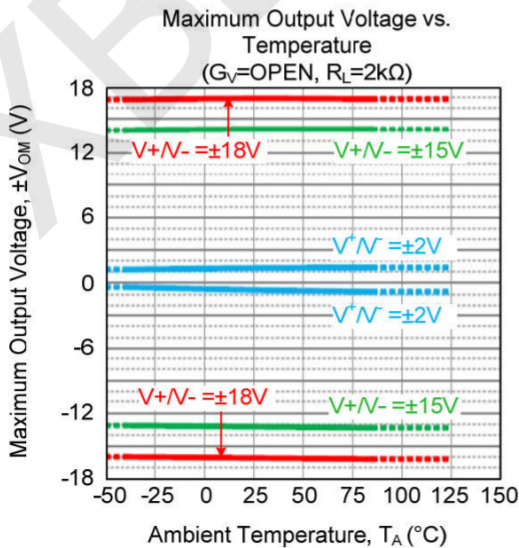
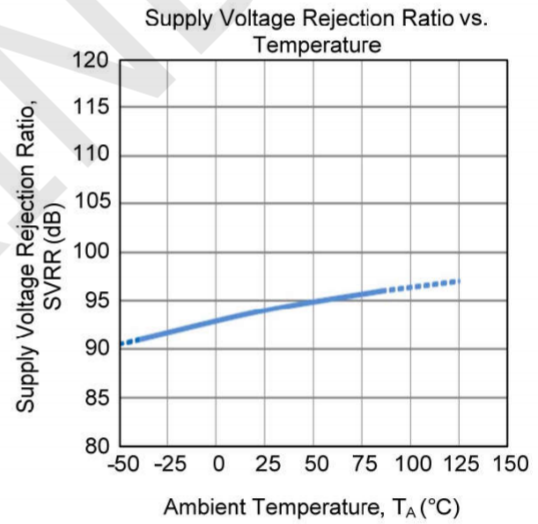
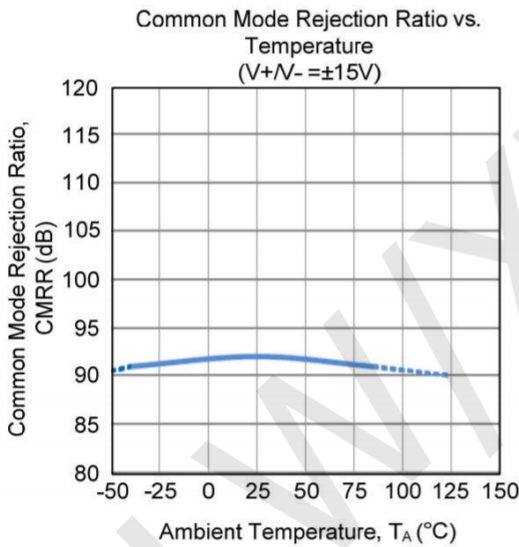
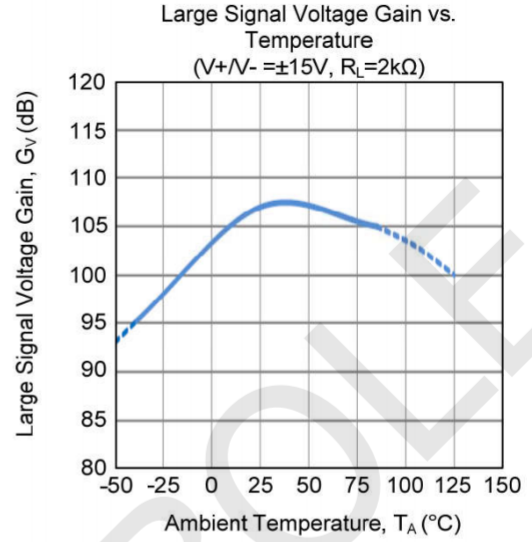
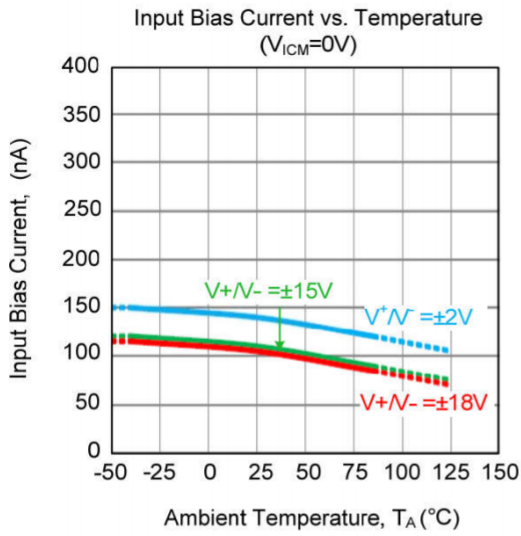

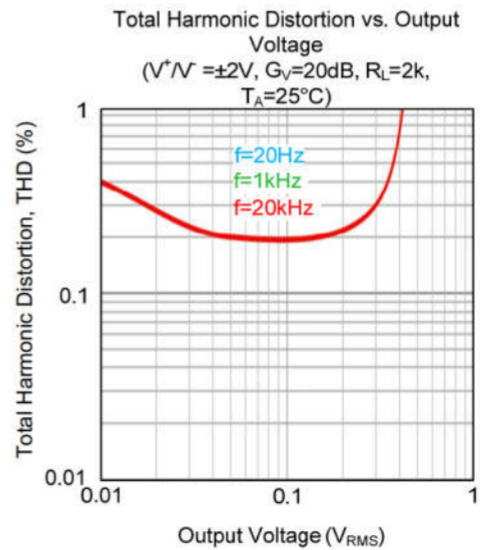
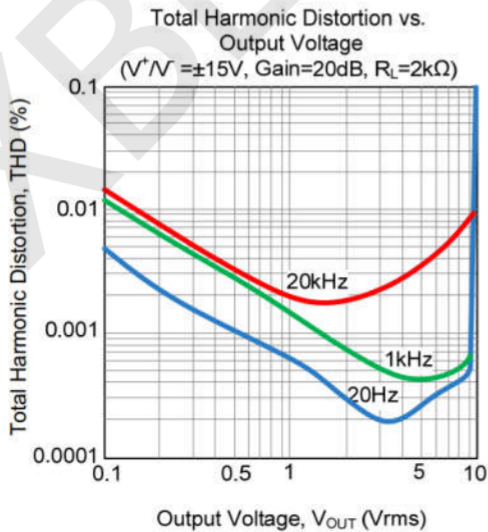
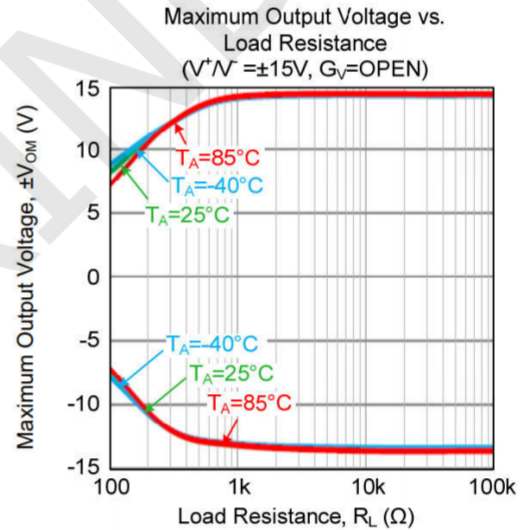
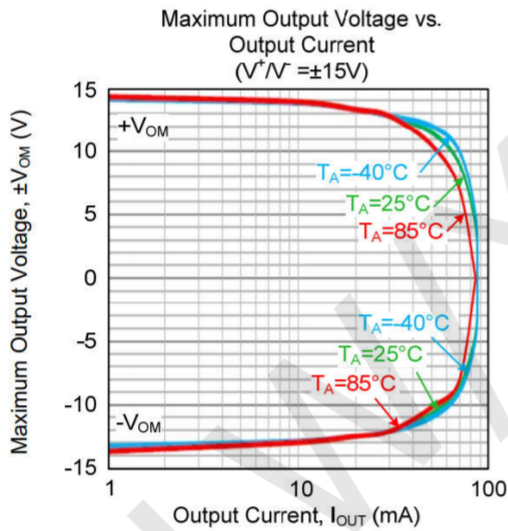
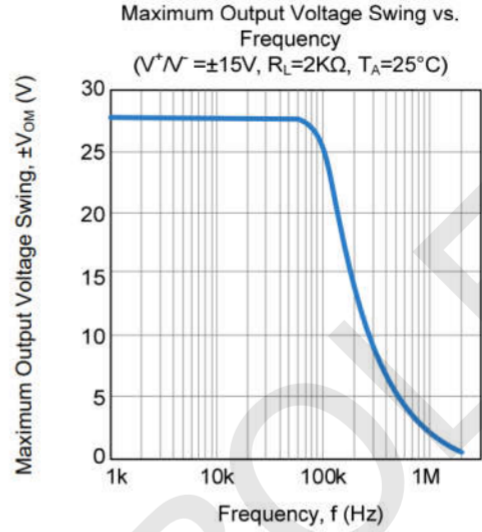
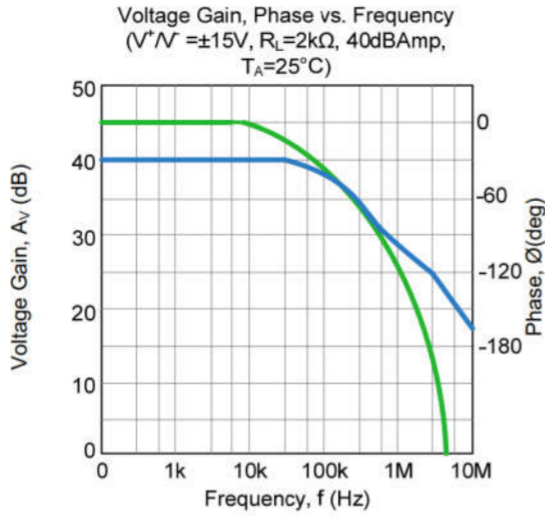

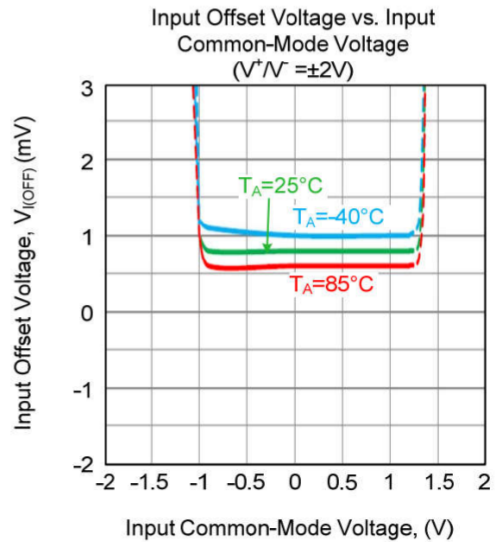
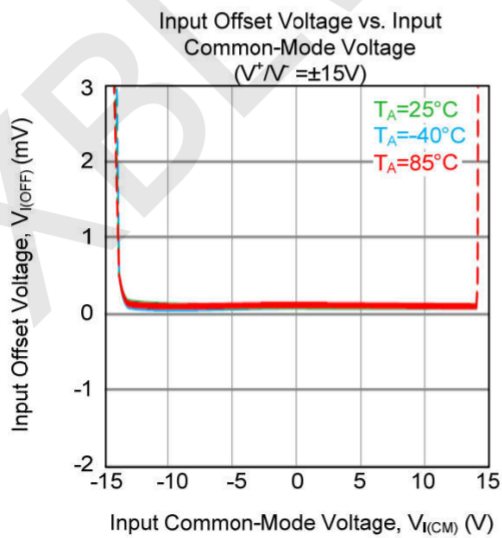
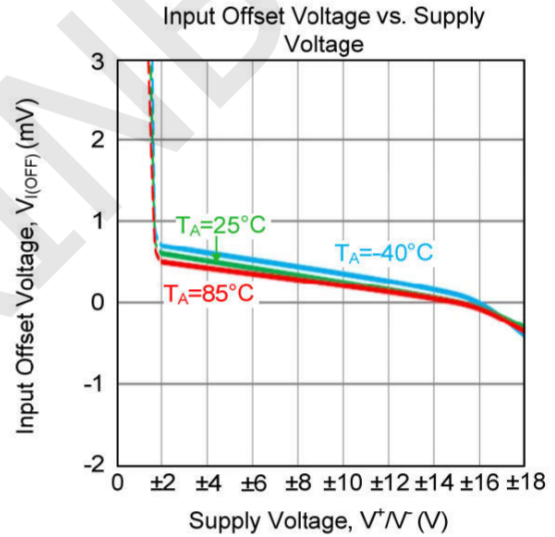
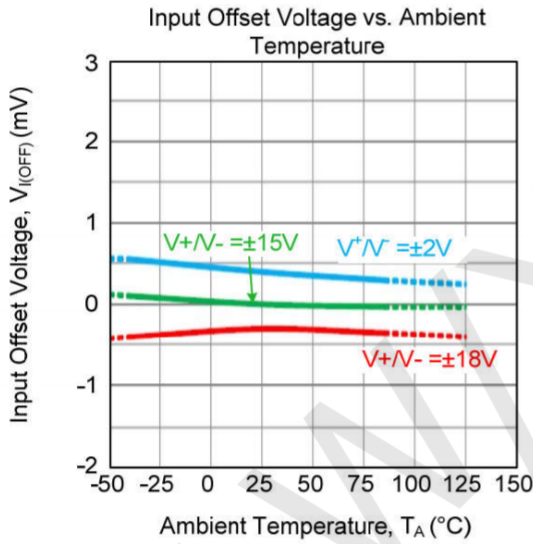
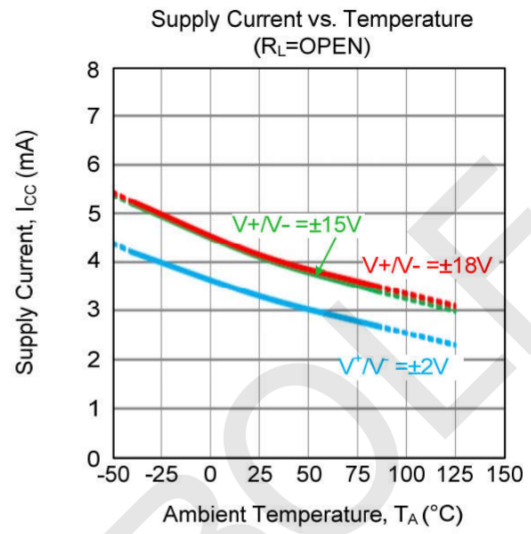
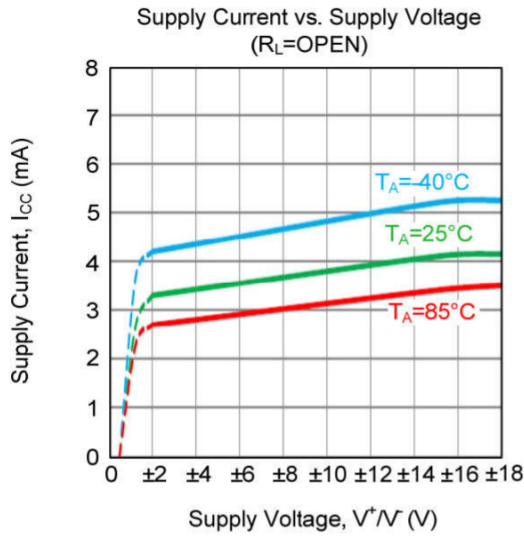

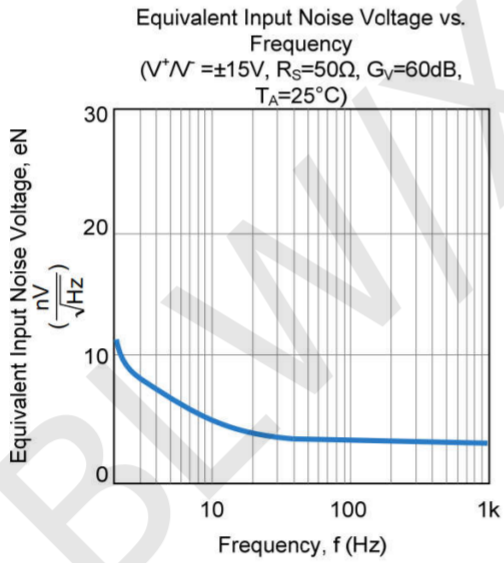
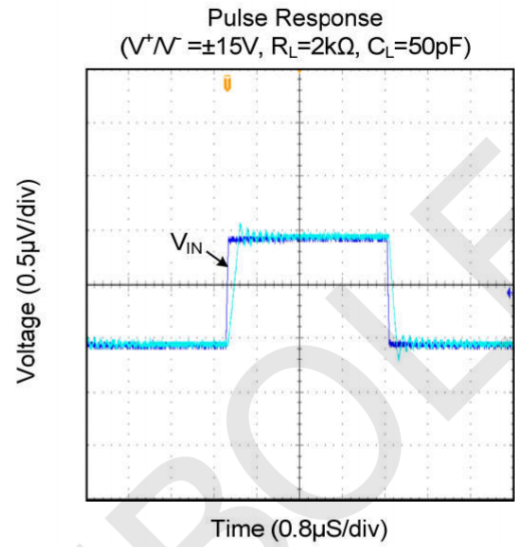
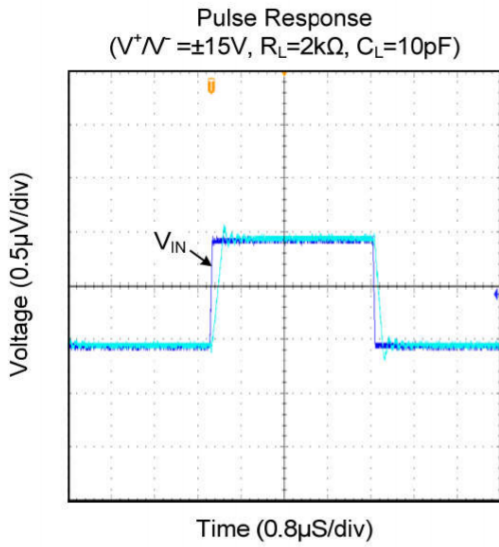

• SOP-8

Symbol	Dimensions In Millimeters		Symbol	Dimensions In Inches	
	Min (mm)	Max (mm)		Min (in)	Max (in)
A	1.350	1.750	A	0.053	0.069
A1	0.100	0.250	A1	0.004	0.010
A2	1.350	1.550	A2	0.053	0.061
b	0.330	0.510	b	0.013	0.020
c	0.170	0.250	c	0.006	0.010
D	4.700	5.100	D	0.185	0.200
E	3.800	4.000	E	0.150	0.157
E1	5.800	6.200	E1	0.228	0.224
e	1.270 (BSC)		e	0.050 (BSC)	
L	0.400	1.270	L	0.016	0.050
θ	0°	8°	θ	0°	8°

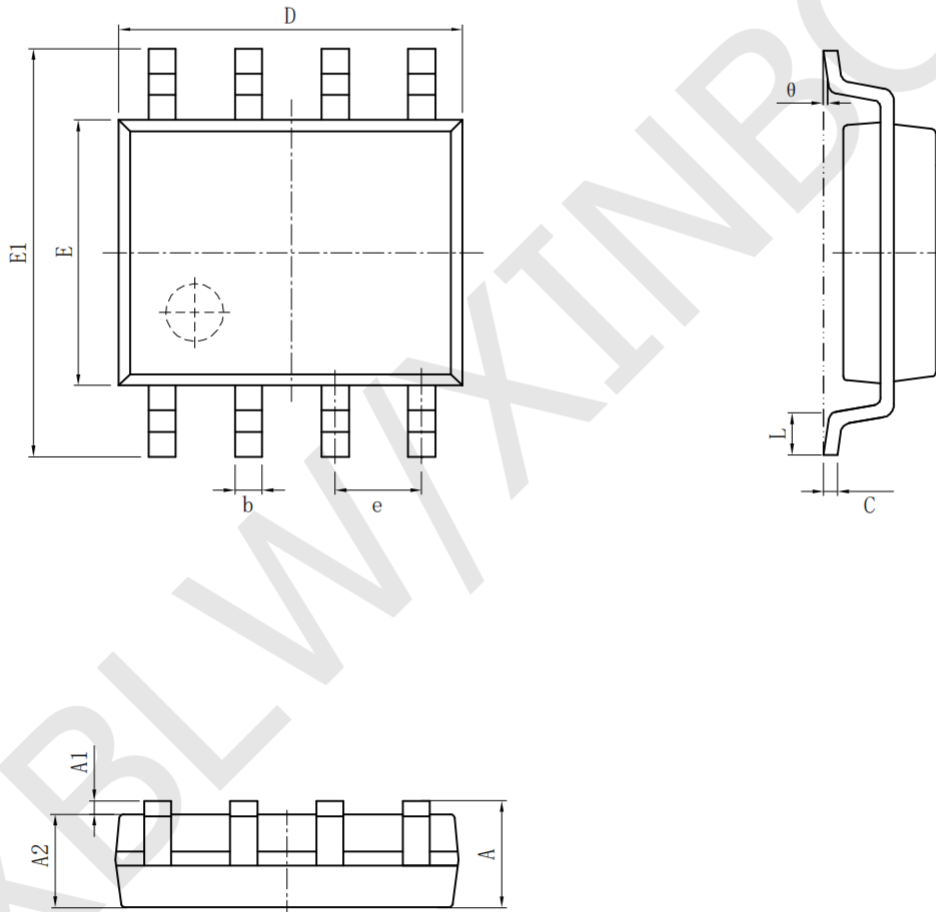

## Statement:

- XBLW reserves the right to modify the product manual without prior notice! Before placing an order, customers need to confirm whether the obtained information is the latest version and verify the completeness of the relevant information.
- Any semi-guide product is subject to failure or malfunction under specified conditions. It is the buyer's responsibility to comply with safety standards when using XBLW products for system design and whole machine manufacturing. And take the appropriate safety measures to avoid the potential in the risk of loss of personal injury or loss of property situation!
- XBLW products have not been licensed for life support, military, and aerospace applications, and therefore XBLW is not responsible for any consequences arising from the use of this product in these areas.
- If any or all XBLW products (including technical data, services) described or contained in this document are subject to any applicable local export control laws and regulations, they may not be exported without an export license from the relevant authorities in accordance with such laws.
- The specifications of any and all XBLW products described or contained in this document specify the performance, characteristics, and functionality of said products in their standalone state, but do not guarantee the performance, characteristics, and functionality of said products installed in Customer's products or equipment. In order to verify symptoms and conditions that cannot be evaluated in a standalone device, the Customer should ultimately evaluate and test the device installed in the Customer's product device.
- XBLW documentation is only allowed to be copied without any alteration of the content and with the relevant authorization. XBLW assumes no responsibility or liability for altered documents.
- XBLW is committed to becoming the preferred semiconductor brand for customers, and XBLW will strive to provide customers with better performance and better quality products.