

Description:

This N-Channel MOSFET uses advanced Planar technology and design to provide excellent $R_{DS(on)}$ with low gate charge. It can be used in a wide variety of applications.

Features:

- 1) $V_{DS}=600V, I_D=12A, R_{DS(ON)} < 600m\ \Omega @ V_{GS}=10V$ (Typ: $550m\ \Omega$)
- 2) Low gate charge.
- 3) Green device available.
- 4) Advanced high cell density Planar technology for ultra low $R_{DS(ON)}$.
- 5) Excellent package for good heat dissipation.

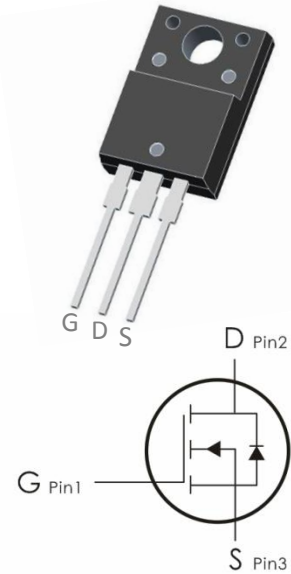

Package Marking and Ordering Information:

Part NO.	Marking	Package	Packing
FN12NG-S	N12N-S	TO- 220F	50 pcs/Tube

Absolute Maximum Ratings: ($T_C=25^\circ C$ unless otherwise noted)

Symbol	Parameter	Ratings	Units
V_{DS}	Drain-Source Voltage	600	V
V_{GS}	Gate-Source Voltage	± 30	V
I_D	Continuous Drain Current ¹	12	A
	Continuous Drain Current- $T_C=100^\circ C$ ¹	8.4	
I_{DM}	Pulsed Drain Current ²	48	
P_D	Power Dissipation	70	W
E_{AS}	Single pulse avalanche energy ³	870	mJ
T_J, T_{STG}	Operating and Storage Junction Temperature Range	-55-+150	$^\circ C$

Thermal Characteristics:

Symbol	Parameter	Max	Units
$R_{\theta JC}$	Thermal Resistance, Junction to Case	2.27	$^\circ C/W$
$R_{\theta JA}$	Thermal Resistance, Junction to Ambient	62.5	$^\circ C/W$

Electrical Characteristics: ($T_C=25^\circ\text{C}$ unless otherwise noted)

Symbol	Parameter	Conditions	Min	Typ	Max	Units
Off Characteristics						
BV_{DSS}	Drain-Source Breakdown Voltage	$V_{GS}=0V, I_D=250\ \mu\text{A}$	600	---	---	V
I_{DSS}	Zero Gate Voltage Drain Current	$V_{GS}=0V, V_{DS}=600V$	---	---	10	μA
I_{GSS}	Gate-Source Leakage Current	$V_{GS}=\pm 30V, V_{DS}=0A$	---	---	± 100	nA
On Characteristics						
$V_{GS(th)}$	Gate-Source Threshold Voltage	$V_{GS}=V_{DS}, I_D=250\ \mu\text{A}$	2	3	4	V
$R_{DS(on)}$	Drain-Source On Resistance ⁴	$V_{GS}=10V, I_D=10A$	---	550	600	$\text{m}\Omega$
Dynamic Characteristics						
C_{iss}	Input Capacitance	$V_{DS}=25V, V_{GS}=0V, f=1\text{MHz}$	---	1920	---	pF
C_{oss}	Output Capacitance		---	174.3	--	
C_{rss}	Reverse Transfer Capacitance		---	18.9	---	
Switching Characteristics						
$t_{d(on)}$	Turn-On Delay Time	$V_{DS}=300V, I_D=12A,$ $R_{ENG}=25\ \Omega, V_{GS}=10V$	---	31.5	---	ns
t_r	Rise Time		---	84	---	ns
$t_{d(off)}$	Turn-Off Delay Time		---	151.2	---	ns
t_f	Fall Time		---	80.8	---	ns
Q_g	Total Gate Charge	$V_{GS}=10V, V_{DS}=480V,$ $I_D=12A$	---	44	---	nC
Q_{gs}	Gate-Source Charge		---	7	---	nC
Q_{gd}	Gate-Drain "Miller" Charge		---	19.4	---	nC
Drain-Source Diode Characteristics						
V_{SD}	Diode Forward Voltage	$V_{GS}=0V, I_{SD}=12A$	---	---	1.4	V
I_S	Continuous Drain Current	$V_D=V_G=0V$	---	---	8.5	A
I_{SM}	Pulsed Drain Current		---	---	34.2	A
T_{rr}	Reverse Recovery Time	$I_F=12A, T_J=25^\circ\text{C}$	---	380	---	ns
Q_{rr}	Reverse Recovery Charge	$di/dt=100A/\mu\text{s}$	---	3.5	---	nC

Notes:

1. Computed continuous current assumes the condition of $T_{j,Max}$ while the actual continuous current depends on the thermal & electro-mechanical application board design
2. Repetitive Rating: Pulse Width Limited by Maximum Junction Temperature
3. EAS condition : $T_J=25^{\circ}C, V_{DD}=300V, V_G=10V, L=0.5mH$
4. Pulse Test: Pulse Width $\leq 300\mu s$, Duty Cycle $\leq 0.5\%$

Typical Characteristics: ($T_C=25^{\circ}C$ unless otherwise noted)

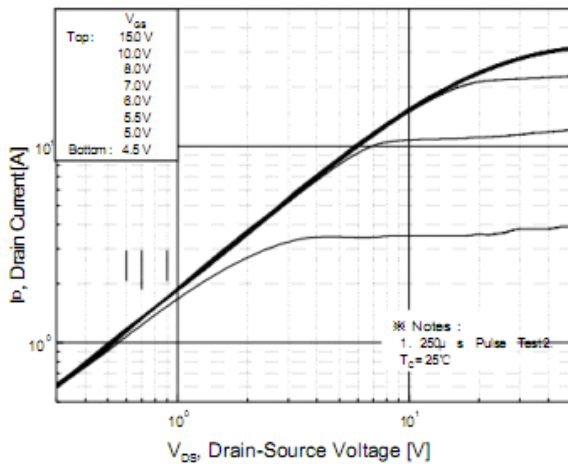

Figure 1. On-Region Characteristics

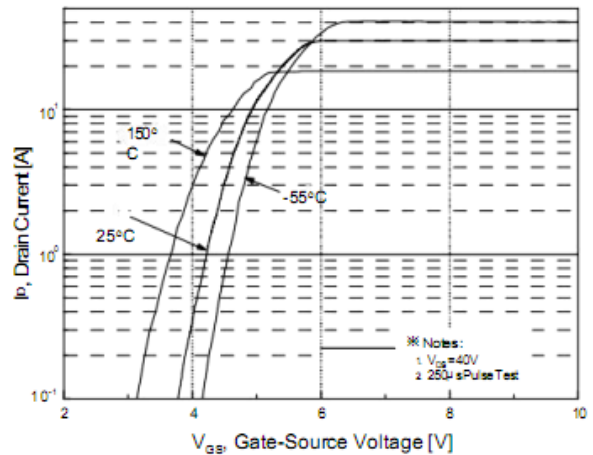

Figure 2. Transfer Characteristics

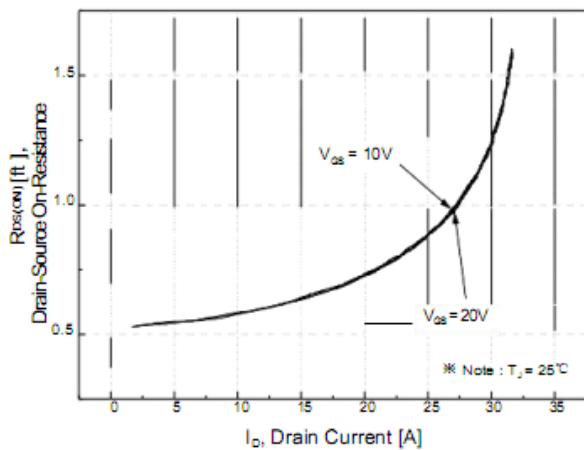

Figure 3. On-Resistance Variation vs Drain Current and Gate Voltage

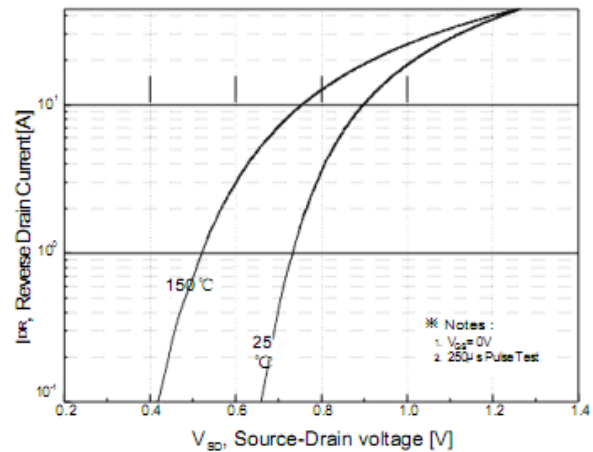

Figure 4. Body Diode Forward Voltage Variation with Source Current and Temperature

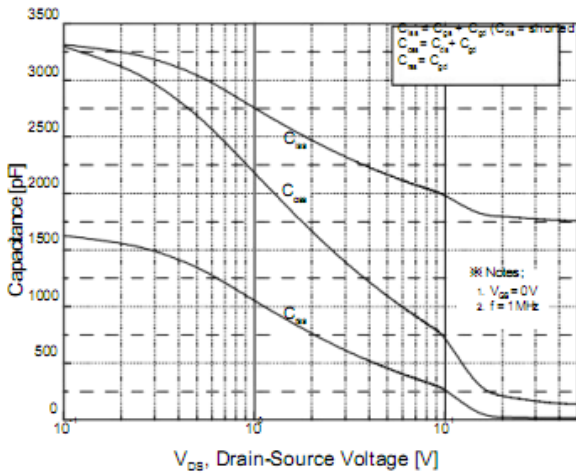

Figure 5. Capacitance Characteristics

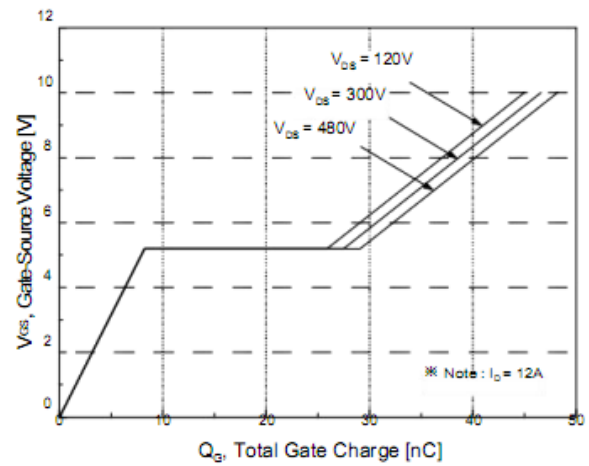

Figure 6. Gate Charge Characteristics

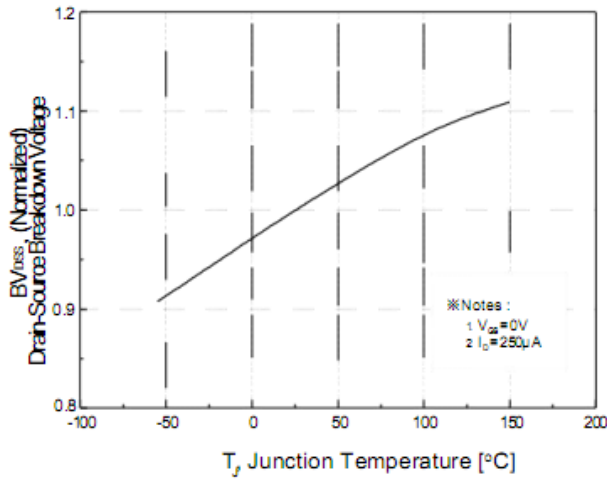

Figure 7. Breakdown Voltage Variation vs Temperature

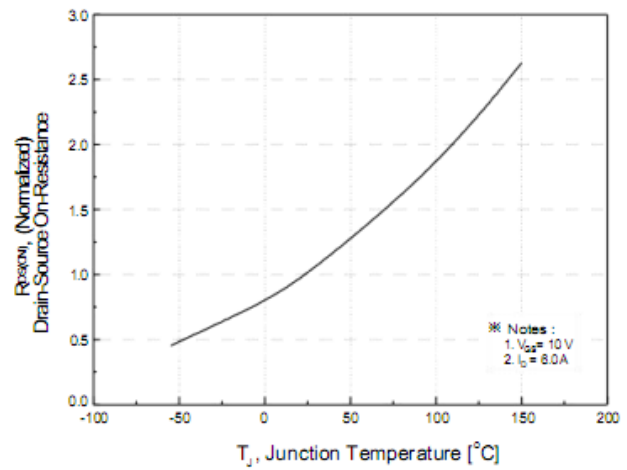

Figure 8. On-Resistance Variation vs Temperature

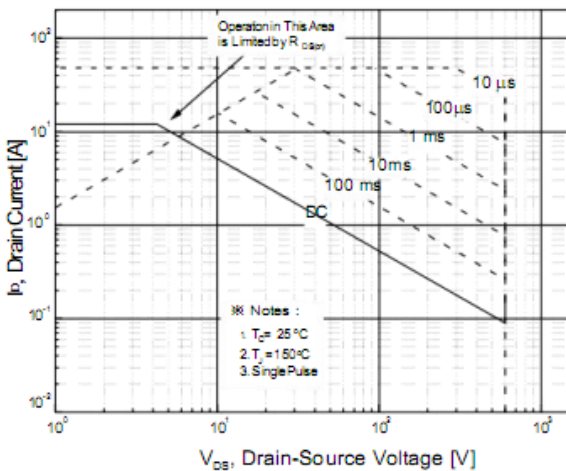

Figure 9-2. Maximum Safe Operating Area

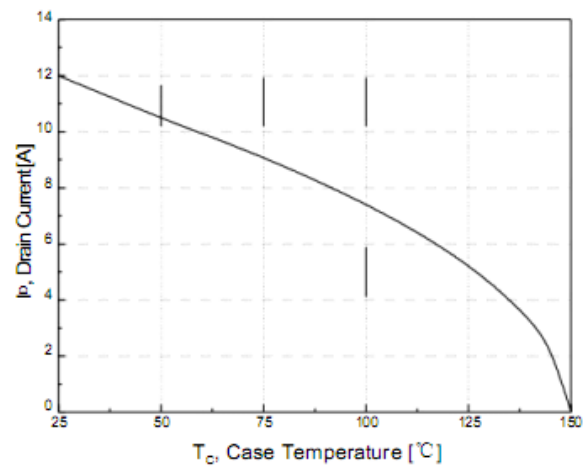

Figure 10. Maximum Drain Current vs Case Temperature

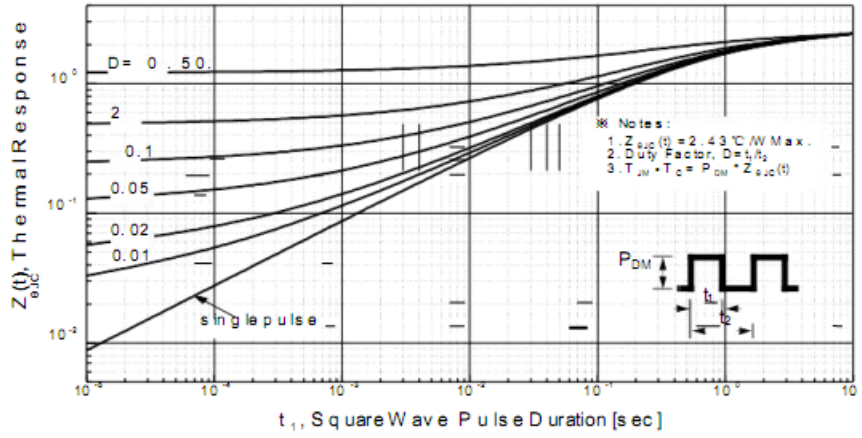
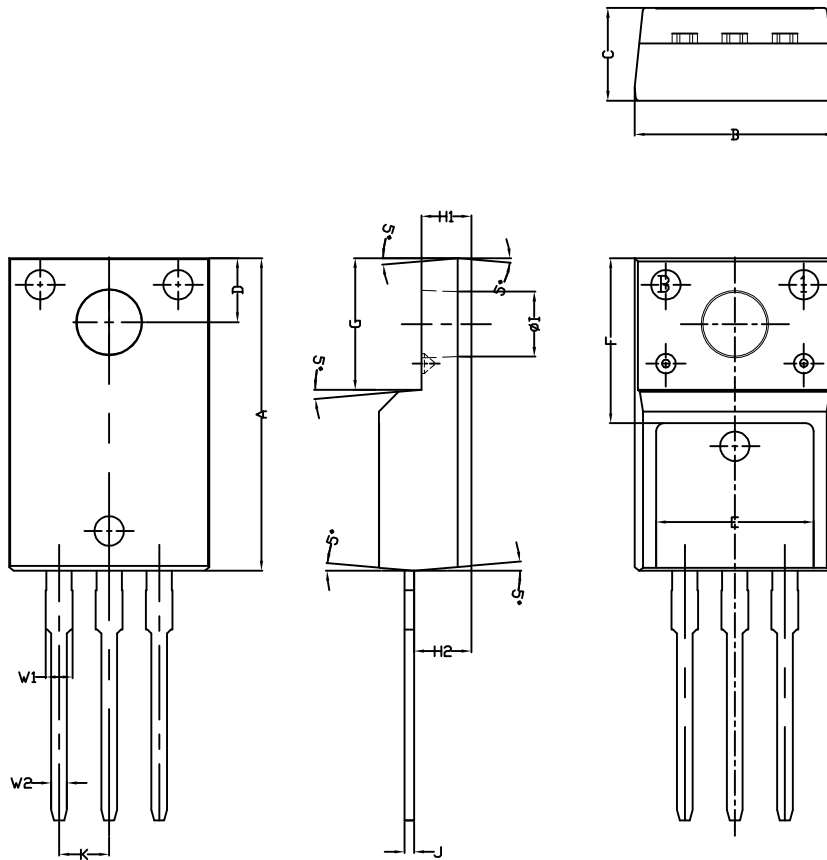

Figure 11-2. Transient Thermal Response Curve

TO-220F Package Information:



Symbol	MM			Inch		
	Min	Mim	Max	Min	Mim	Max
A	15.67	15.87	16.07	0.6169	0.6248	0.6328
B	9.86	10.16	10.46	0.3882	0.4000	0.4118
C	4.50	4.70	4.90	0.1772	0.1850	0.1929
D	3.15	3.35	3.55	0.1240	0.1319	0.1398
E	7.80	8.00	8.20	0.3071	0.3150	0.3228
F	8.18	8.38	8.58	0.3220	0.3299	0.3378
H1	2.34	2.54	2.84	0.0921	0.1000	0.1118
H2	2.40	2.90	3.40	0.0945	0.1141	0.1339
I	3.10	3.30	3.50	0.1220	0.1299	0.1378
W1	1.08	1.28	1.48	0.0425	0.0504	0.0583
W2	0.70	0.80	0.90	0.0276	0.0315	0.0354
K	2.44	2.54	2.64	0.0961	0.1000	0.1039
G	6.48	6.68	6.88	0.2551	0.2630	0.2709
J	0.45	0.50	0.6	0.0177	0.0197	0.0236

Marking Information:

- ①. Doingter LOGO
- ②. Date Code(YWWG / R)
 - Y : Year Code , last digit of the year
 - WW : Week Code(01-53)
 - G/R : G(Green) /R(Lead Free)
- ③. Part NO.

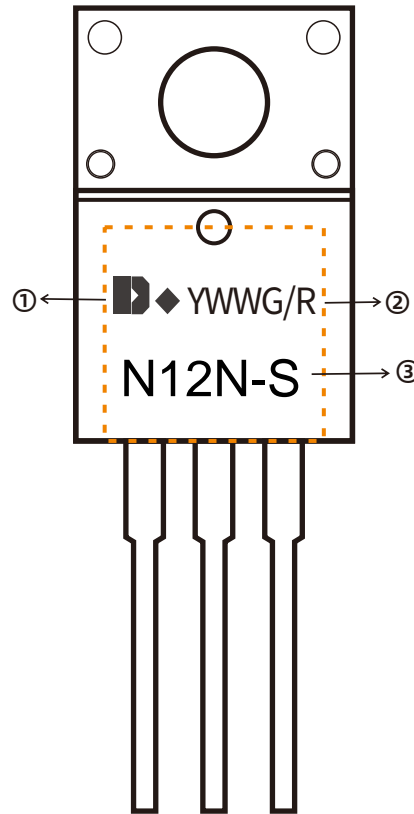

Previous Version

Version	Date	Subjects (major changes since last revision)
1.0	2026-02-07	Release of final version

Attention :

- Information furnished in this document is believed to be accurate and reliable. However, Shenzhen Doingter Semiconductor Co.,Ltd. assumes noresponsibility for the consequences of use without consideration for such information nor use beyond it.
- Information mentioned in this document is subject to change without notice, apart from that when an agreement is signed, Shenzhen Doingter complies with the agreement. Products and information provided in this document have no infringement of patents.
- Shenzhen Doingter assumes noresponsibility for any infringement of other rights of third parties which may result from the use of such products and information. This document supersedes and replaces all information previously supplied.



Is a registered trademark of Shenzhen Doingter Semiconductor Co., Ltd. Copyright © 2013 Shenzhen DoingterSemiconductor Co.,Ltd. Printed All rights reserved.