

FEATURES

Ideally suited for automatic insertion
For Switching and AF Amplifier Applications

MARKING

BC856A=3A;BC856B=3B;

BC857A=3E;BC857B=3F;BC857C=3G;

BC858A=3J; BC858B=3K; BC858C=3L

3 x

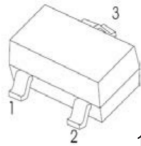

1.BASE
2.EMITTER
3.COLLECTOR

MAXIMUM RATINGS AND ELECTRICAL CHARACTERISTICS

Maximum ratings ($T_a=25^{\circ}\text{C}$ unless otherwise noted)

Symbol	Parameter	Value	Unit
V_{CBO}	Collector-Base Voltage		
	BC856	-80	V
	BC857	-50	
	BC858	-30	
V_{CEO}	Collector-Emitter Voltage		
	BC856	-65	V
	BC857	-45	
	BC858	-30	
V_{EBO}	Emitter-Base Voltage	-5	V
I_C	Collector Current –Continuous	-0.1	A
P_C	Collector Power Dissipation	225	mW
$R_{\theta JA}$	Thermal Resistance From Junction To Ambient	625	$^{\circ}\text{C}/\text{W}$
T_J	Junction Temperature	150	$^{\circ}\text{C}$
T_{stg}	Storage Temperature	-65~+150	$^{\circ}\text{C}$

Electrical Characteristics

Parameter	Symbol	Test conditions	Min	Max	Unit
Collector-base breakdown voltage	BC856	$I_C = -10\mu A, I_E = 0$	-80		V
	BC857		-50		
	BC858		-30		
Collector-emitter breakdown voltage	BC856	$I_C = -10mA, I_B = 0$	-65		V
	BC857		-45		
	BC858		-30		
Emitter-base breakdown voltage	V_{EBO}	$I_E = -1\mu A, I_C = 0$	-5		V
Collector cut-off current	BC856	$V_{CB} = -70V, I_E = 0$		-0.1	μA
	BC857		$V_{CB} = -45V, I_E = 0$		
	BC858		$V_{CB} = -25V, I_E = 0$		
Collector cut-off current	BC856	$V_{CE} = -60V, I_B = 0$		-0.1	μA
	BC857		$V_{CE} = -40V, I_B = 0$		
	BC858		$V_{CE} = -25V, I_B = 0$		
Emitter cut-off current	I_{EBO}	$V_{EB} = -5V, I_C = 0$		-0.1	μA
DC current gain	BC856	$V_{CE} = -5V, I_C = -2mA$	125	475	
	BC857		125	800	
	BC856A, 857A, 858A		125	250	
	BC856B, 857B, 858B		220	475	
	BC857C, BC858C		420	800	
Collector-emitter saturation voltage	$V_{CE(sat)}$	$I_C = -100mA, I_B = -5mA$		-0.5	V
Base-emitter saturation voltage	$V_{BE(sat)}$	$I_C = -100mA, I_B = -5mA$		-1.1	V
Transition frequency	f_T	$V_{CE} = -5V, I_C = -10mA$ $f = 100MHz$	100		MHz
Collector capacitance	C_{ob}	$V_{CB} = -10V, f = 1MHz$		4.5	pF

RATING AND CHARACTERISTIC CURVES

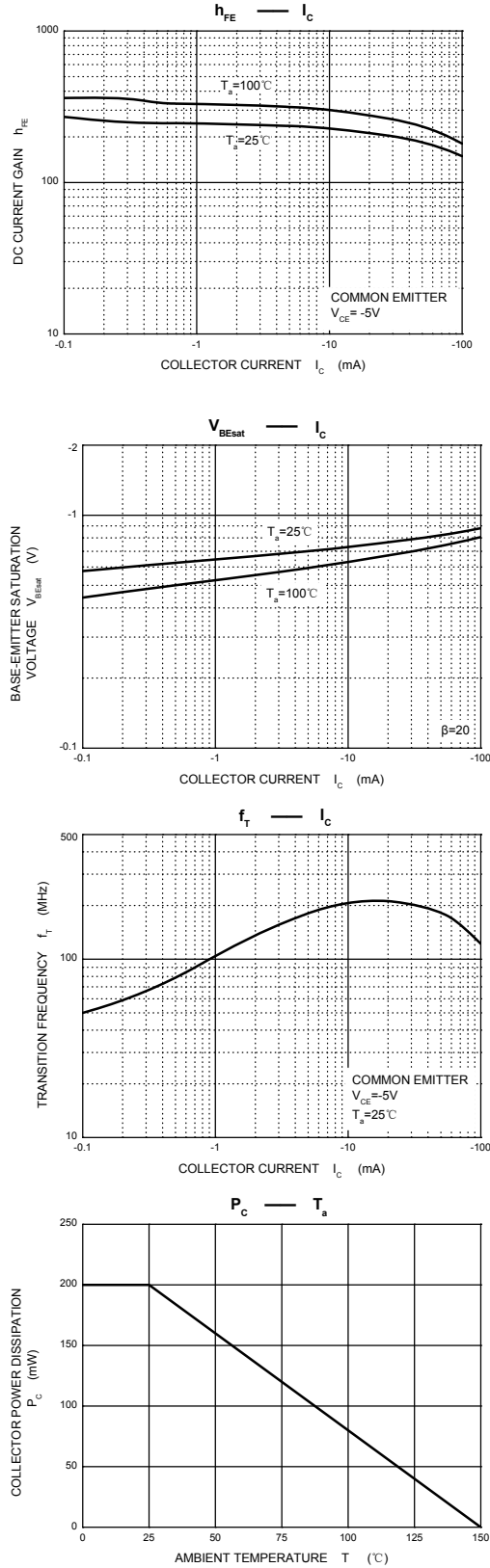
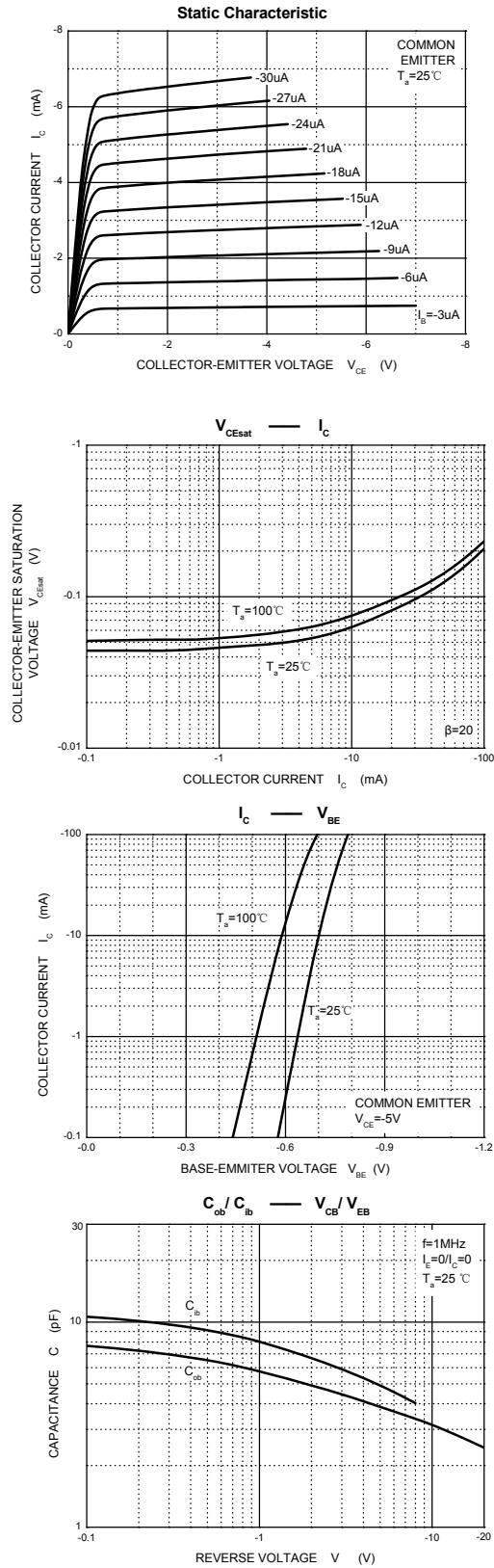

Soldering parameters

Reflow Condition		Pb-Free assembly (see as below)
Pre Heat	-Temperature Min ($T_{s(min)}$)	+150 °C
	-Temperature Max ($T_{s(max)}$)	+200 °C
	-Time (Min to Max) (ts)	60-180 secs.
Average ramp up rate (Liquid us Temp (T_L) to peak)		3 °C/sec. Max
$T_{s(max)}$ to T_L - Ramp-up Rate		3 °C/sec. Max
Reflow	-Temperature (T_L) (Liquid us)	+217 °C
	-Temperature (t_L)	60-150 secs.
Peak Temp (T_P)		+260(+0/-5) °C
Time within 5 °C of actual Peak Temp (t_p)		30 secs. Max
Ramp-down Rate		6 °C/sec. Max
Time 25 °C to Peak Temp (T_P)		8 min. Max
Do not exceed		+260 °C

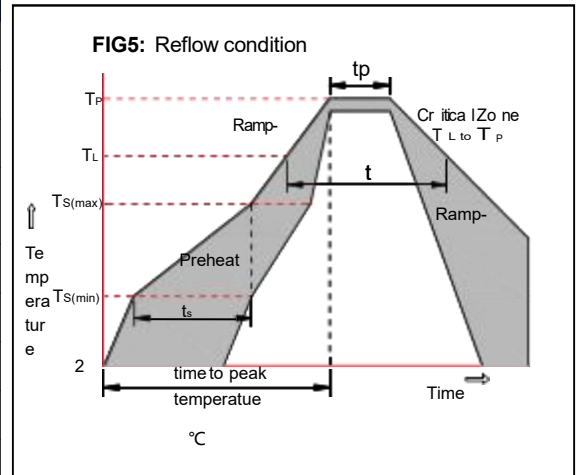

Package Dimensions & Suggested Pad Layout

SOT23

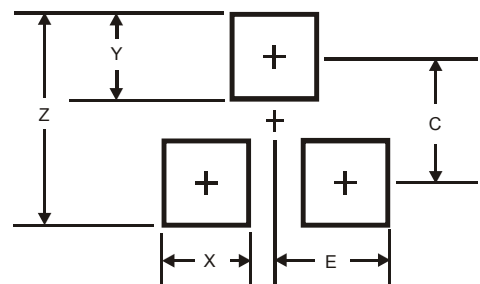
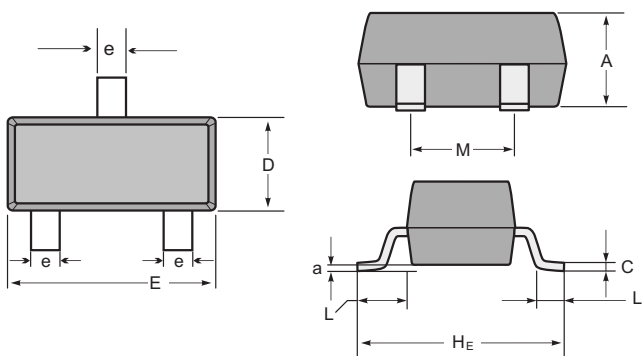

SOT-23 mechanical data

UNIT	A	C	D	E	HE	e	M	L	L1	a	
mm	max	1.1	0.15	1.4	3.0	2.6	0.5	1.95	0.55 (ref)	0.36 (ref)	0.0
	min	0.9	0.08	1.2	2.8	2.2	0.3	1.7			0.15
mil	max	43	6	55	118	102	20	77	22 (ref)	14 (ref)	0.0
	min	35	3	47	110	87	12	67			6

Dimensions	SOT23
Z	2.9
X	0.8
Y	0.9
C	2.0
E	1.35

Tape & reel specification

Tape		Symbol	Dimension (mm)
		P0	4.00±0.10
		P1	4.00±0.10
		P2	2.00±0.10
		D0	1.55±0.10
		D1	1.05±0.10
		E	1.55±0.10
		F	3.60±0.10
		W	8.00±0.10
		A0	3.80±0.20
		B0	3.25±0.20
		K0	1.45±0.10
		T	0.25±0.05
		D2	178.0±3.0
		D3	55Min.
		D4	R24.0±3.0
G	R82.0±3.0		
I	13.0±2.0		
W1	11.0±3.0		
Quantity: 3000PCS			

7" Reel

