

FEATURES

- We declare that the material of product compliance with RoHS requirements and Halogen Free.
- S- prefix for automotive and other applications requiring unique site and control change requirements; AEC-Q101 qualified and PPAP capable.
- 2 Unidirectional transil functions
- Low leakage current: IR max < 20 μ A at VRM
- 300W peak pulse power(8/20 μ s)
- Transient protection for data lines as per IEC61000-4-2(ESD) 30KV(air) 30KV(contact) IEC61000-4-5(Lightning) see IPPM below

APPLICATIONS

- Computers
- Printers
- Communication systems



SOT-23

1. GATE
2. SOURCE
3. DRAIN

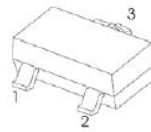

Equivalent Circuit

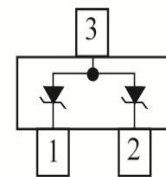

MAXIMUM RATINGS AND ELECTRICAL CHARACTERISTICS

Maximum ratings ($T_a=25^{\circ}\text{C}$ unless otherwise noted)

Parameter	Symbol	Limits	Unit
Peak Pulse Power ($t_p = 8/20\mu\text{s}$)	PPP	300	W
Lead Solder Temperature – Maximum (10 Second Duration)	TL	260	$^{\circ}\text{C}$
Storage Temperature Range	Tstg	-55 ~ +150	$^{\circ}\text{C}$
Operating Temperature Range	Top	-40 ~ +125	$^{\circ}\text{C}$
Maximum junction temperature	Tj	150	$^{\circ}\text{C}$
Electrostatic discharge	VPP		kV
IEC61000-4-2 air discharge		15	
IEC61000-4-2 contact discharge		8	

Electrical Characteristics

VRWM (V)	IR (μA) @VRWM	VBR (V) @IT (Note 1)	IT (mA)	VC (V) @IPP=1A	VC (V) @IPP= 13A	IPP(A) @tp=8/20μs	C (pF) f=1MHz
Max.	Max.	Min.		Max.	Max.	Max.	Max.
3.3	1	5	1	12	23	13	220

1. 8/20 waveform used.

Electronics Parameter

Symbol	Parameter
VRM	Stand-off voltage
VBR	Breakdown voltage
VCL	Clamping voltage
IRM	Leakage current
IPPM	Peak pulse current

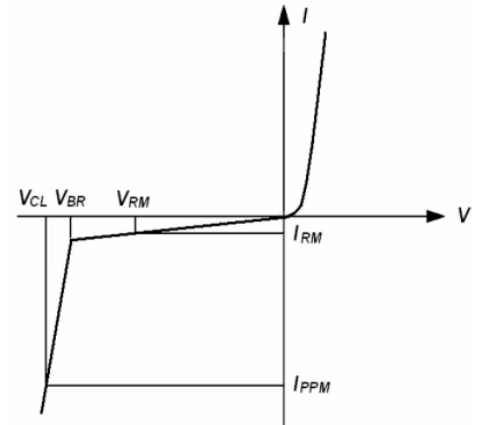

RATING AND CHARACTERISTIC CURVES

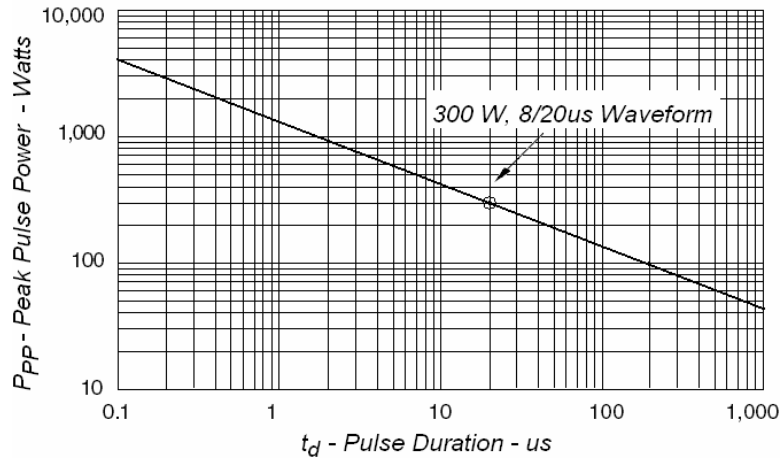

Fig1. Peak Pulse Power VS Pulse Time

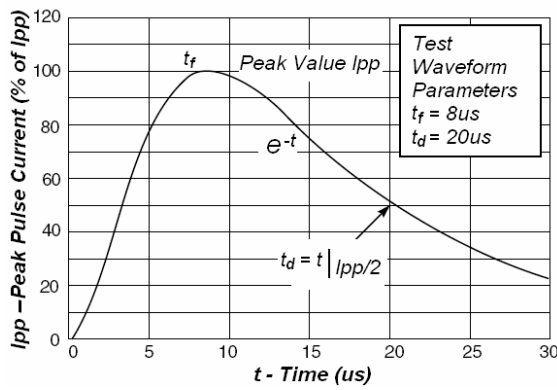

Fig2. Pulse Waveform

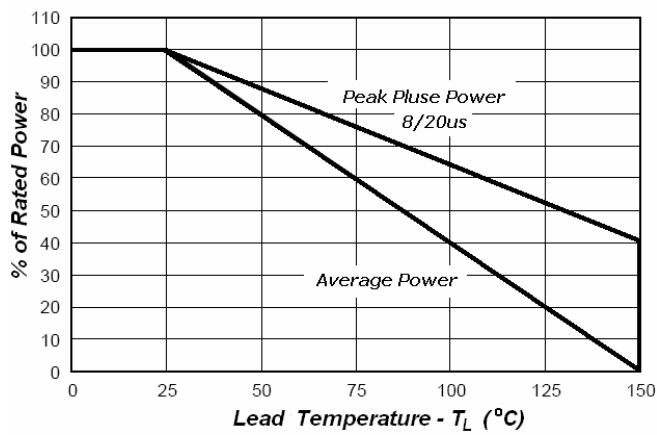

Fig3. Power Derating

Soldering parameters

Reflow Condition		Pb-Free assembly (see as below)
Pre Heat	-Temperature Min ($T_{s(min)}$)	+150 °C
	-Temperature Max ($T_{s(max)}$)	+200 °C
	-Time (Min to Max) (ts)	60-180 secs.
Average ramp up rate (Liquid us Temp (T_L) to peak)		3 °C/sec. Max
$T_{s(max)}$ to T_L - Ramp-up Rate		3 °C/sec. Max
Reflow	-Temperature (T_L) (Liquid us)	+217 °C
	-Temperature (t_L)	60-150 secs.
Peak Temp (T_P)		+260(+0/-5) °C
Time within 5 °C of actual Peak Temp (t_p)		30 secs. Max
Ramp-down Rate		6 °C/sec. Max
Time 25 °C to Peak Temp (T_P)		8 min. Max
Do not exceed		+260 °C



Package Dimensions & Suggested Pad Layout

SOT23

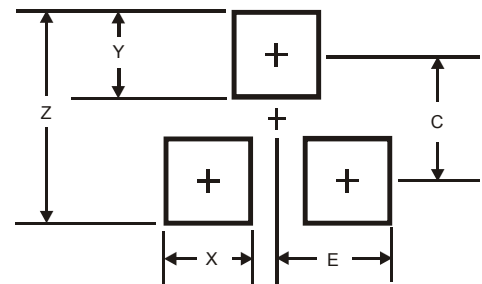
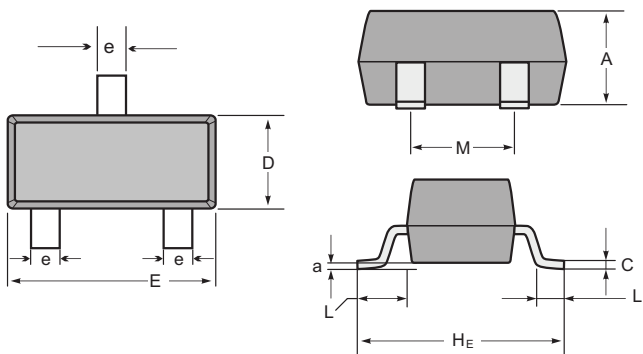

SOT-23 mechanical data

UNIT	A	C	D	E	HE	e	M	L	L1	a	
mm	max	1.1	0.15	1.4	3.0	2.6	0.5	1.95	0.55 (ref)	0.36 (ref)	0.0
	min	0.9	0.08	1.2	2.8	2.2	0.3	1.7			0.15
mil	max	43	6	55	118	102	20	77	22 (ref)	14 (ref)	0.0
	min	35	3	47	110	87	12	67			6

Dimensions	SOT23
Z	2.9
X	0.8
Y	0.9
C	2.0
E	1.35

Tape & reel specification

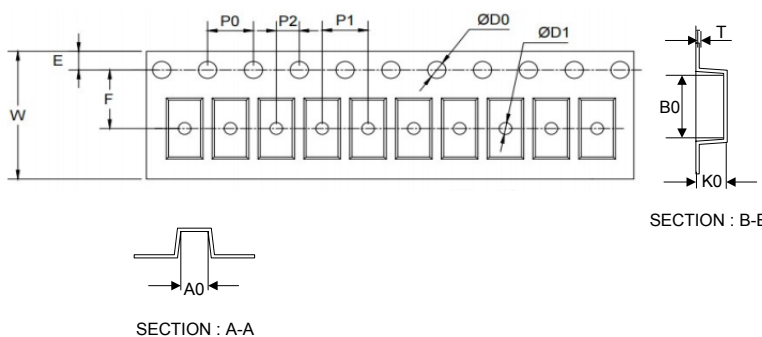
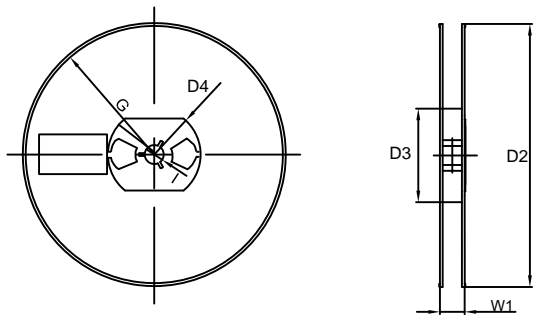
Tape	Symbol	Dimension (mm)	
	P0	4.00±0.10	
	P1	4.00±0.10	
	P2	2.00±0.10	
	D0	1.55±0.10	
	D1	1.05±0.10	
	E	1.55±0.10	
	F	3.60±0.10	
	W	8.00±0.10	
	A0	3.80±0.20	
	B0	3.25±0.20	
	K0	1.45±0.10	
	T	0.25±0.05	
	7" Reel	D2	178.0±3.0
		D3	55Min.
		D4	R24.0±3.0
G		R82.0±3.0	
I		13.0±2.0	
W1		11.0±3.0	
Quantity: 3000PCS			