

FEATURES

- Fast Switching Speed
- Surface Mount Package Ideally Suited for Automatic Insertion
- For General Purpose Switching Applications
- High Conductance

MECHANICAL DATA

- * Case: Molded plastic
- * Lead: Axial leads, solderable per MIL-STD-750, method 2026
- * Polarity: Polarity symbols marked on case
- * Marking: *SL

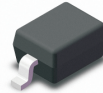

VOLTAGE RANGE
40.0 Volts
CURRENT
1.0 Ampere

MAXIMUM RATINGS AND ELECTRICAL CHARACTERISTICS

Rating 25°C ambient temperature unless otherwise specified.
Single phase half wave, 60Hz, resistive or inductive load.
For capacitive load, derate current by 20%.

TYPE NUMBER	B5819WS	UNITS
Maximum Recurrent Peak Reverse Voltage	40	V
Maximum RMS Voltage	28	V
Maximum DC Blocking Voltage	40	V
Maximum Average Forward Rectified Current See Fig. 1	1.0	A
Peak Forward Surge Current, 8.3 ms single half sine-wave superimposed on rated load (JEDEC method)	25	A
Maximum Instantaneous Forward Voltage at 1.0A	0.58	V
Maximum DC Reverse Current Ta=25°C	0.05	mA
at Rated DC Blocking Voltage Ta=100°C	8	mA
Typical Junction Capacitance (Note1)	30	pF
Typical Thermal Resistance R _{JA} (Note 2)	400	°C/W
Operating Temperature Range T _J	-65 — +125	°C
Storage Temperature Range T _{STG}	-65 — +150	°C

NOTES:

1. Measured at 1MHz and applied reverse voltage of 4.0V D.C.
2. Thermal Resistance Junction to Ambient.

RATING AND CHARACTERISTIC CURVES

FIG.1-TYPICAL FORWARD CURRENT DERATING CURVE

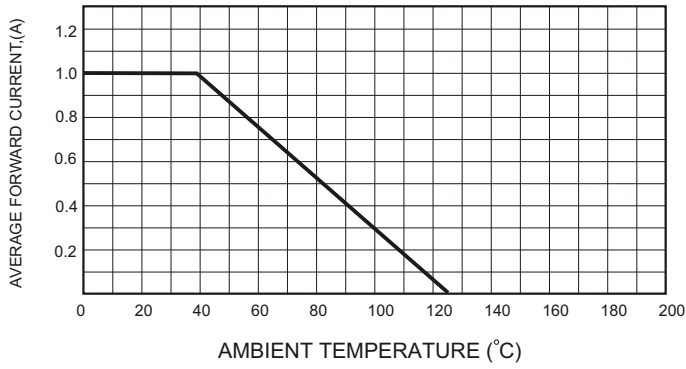

FIG.2-TYPICAL FORWARD CHARACTERISTICS

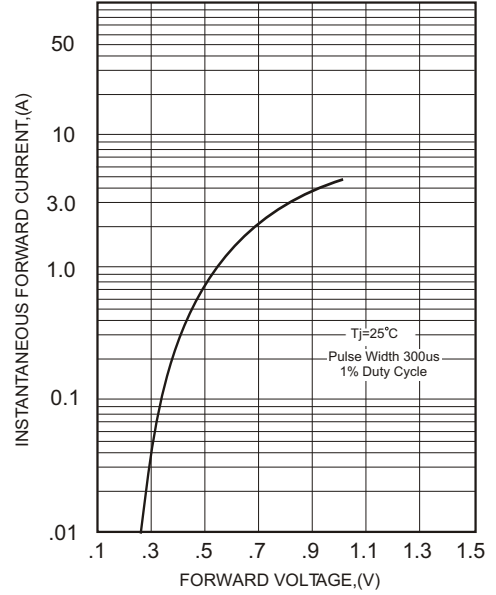

FIG.3-TYPICAL JUNCTION CAPACITANCE

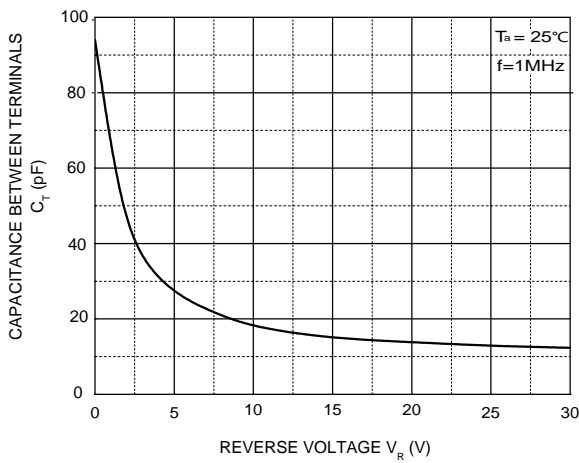
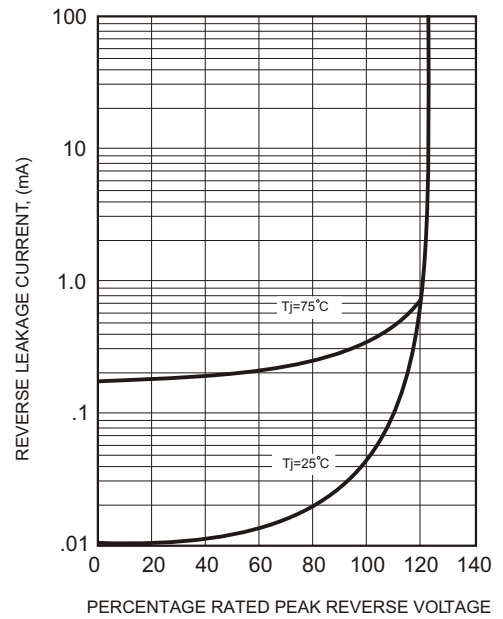

FIG.4 - TYPICAL REVERSE CHARACTERISTICS



Soldering parameters

Reflow Condition		Pb-Free assembly (see as below)
Pre Heat	-Temperature Min ($T_{s(min)}$)	+150°C
	-Temperature Max($T_{s(max)}$)	+200°C
	-Time (Min to Max) (ts)	60-180 secs.
Average ramp up rate (Liquid us Temp (T_L) to peak)		3°C/sec. Max
$T_{s(max)}$ to T_L - Ramp-up Rate		3°C/sec. Max
Reflow	-Temperature(T_L)(Liquid us)	+217°C
	-Temperature(t_L)	60-150 secs.
Peak Temp (T_P)		+260(+0/-5)°C
Time within 5°C of actual Peak Temp (t_p)		30 secs. Max
Ramp-down Rate		6°C/sec. Max
Time 25°C to Peak Temp (T_P)		8 min. Max
Do not exceed		+260°C



Package Dimensions & Suggested Pad Layout

SOD323

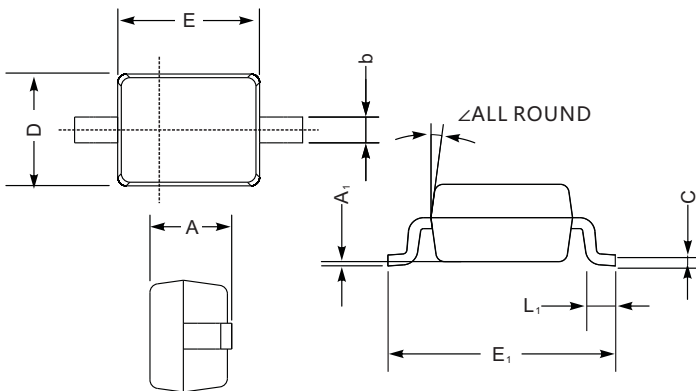

SOD-323 mechanical data

UNIT		A	C	D	E	E ₁	b	L ₁	A ₁	z
mm	max	1.1	0.15	1.4	1.8	2.75	0.4	0.45	0.2	9°
	min	0.8	0.08	1.2	1.4	2.55	0.25	0.2	—	
mil	max	43	5.9	55	70	108	16	16	8	
	min	32	3.1	47	63	100	9.8	7.9	—	

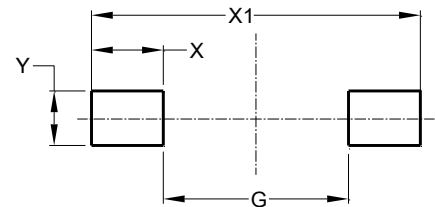

Dimensions	Value (in mm)
G	1.40
X	1.20
X1	3.80
Y	1.00

Tape & reel specification

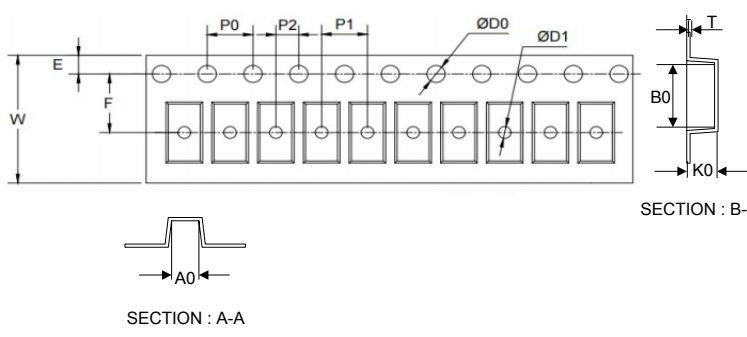
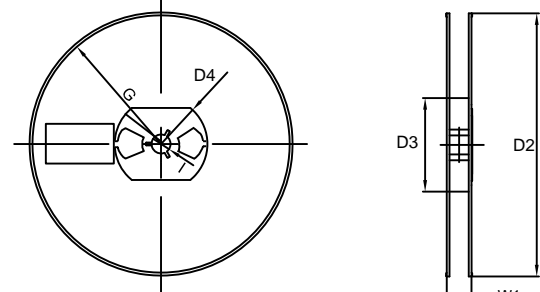
Tape	Symbol	Dimension (mm)
	P0	4.00±0.20
	P1	4.00±0.20
	P2	2.00±0.20
	D0	1.55±0.20
	D1	1.00±0.20
	E	1.55±0.25
	F	3.60±0.20
	W	8.00±0.20
	A0	2.00±0.20
	B0	3.25±0.20
	K0	1.35±0.20
	T	0.23±0.10
	<p>7" Reel</p> 	D2
D3		55Min.
D4		R24.6±2.0
G		R82.0±2.0
I		13.0±2.0
W1		10.20±3.0
Quantity: 3000PCS		