

FEATURES

Built-in bias resistors enable the configuration of an inverter circuit without connecting external input resistors(see equivalent circuit)

The bias resistors consist of thin-film resistors with complete isolation to allow negative biasing of the input.They also have the advantage of almost completely eliminating parasitic effects

Only the on/off conditions need to be set for operation, making device design easy

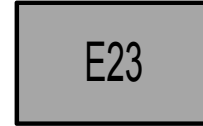

SOT-23

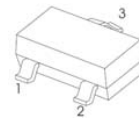

- 1. BASE
- 2. EMITTER
- 3. COLLECTOR

Equivalent Circuit

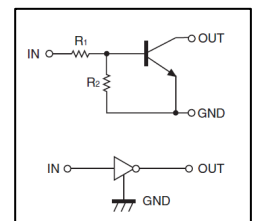

MAXIMUM RATINGS AND ELECTRICAL CHARACTERISTICS

Absolute Maximum Ratings $T_a = 25^\circ\text{C}$

Symbol	Parameter	DTC143ZCA	Unit
V_{CC}	Supply Voltage	50	V
V_{IN}	Input Voltage	-5~+30	V
I_o	Output Current	100	mA
P_D	Power Dissipation	200	mW
T_J, T_{stg}	Operation Junction and Storage Temperature Range	-55~+150	$^\circ\text{C}$

ELECTRICAL CHARACTERISTICS (TA = 25°C unless otherwise noted.)

Parameter	Symbol	Conditions	Min	Typ	Max	Unit
Input voltage	$V_{I(off)}$	$V_{CC}=5V, I_O=100\mu A$	0.5			V
	$V_{I(on)}$	$V_O=0.3V, I_O=5mA$			1.3	V
Output voltage	$V_{O(on)}$	$I_O/I_I=5mA/0.25mA$		0.1	0.3	V
Input current	I_I	$V_I=5V$			1.8	mA
Output current	$I_{O(off)}$	$V_{CC}=50V, V_I=0$			0.5	μA
DC current gain	G_I	$V_O=5V, I_O=10mA$	80			
Input resistance	R_1		3.29	4.7	6.11	k Ω
Resistance ratio	R_2/R_1		8	10	12	
Transition frequency	f_T	$V_O=10V, I_O=5mA, f=100MHz$		250		MHz

RATING AND CHARACTERISTIC CURVES

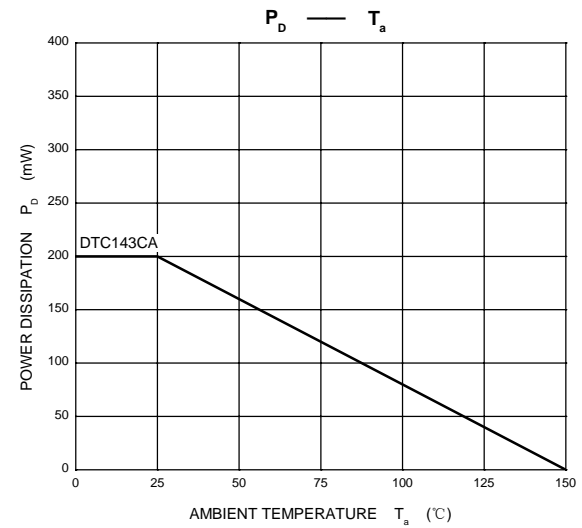
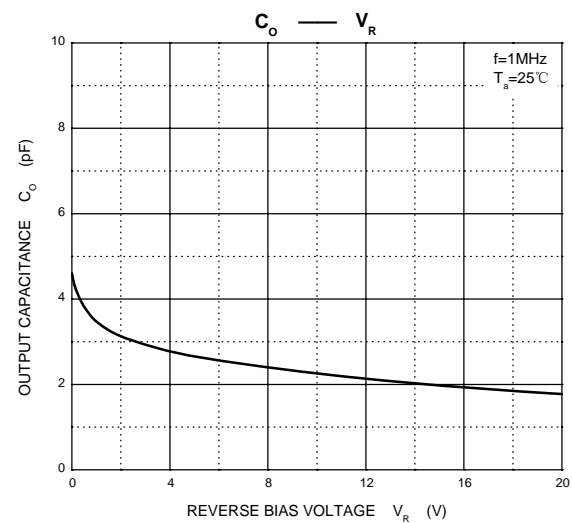
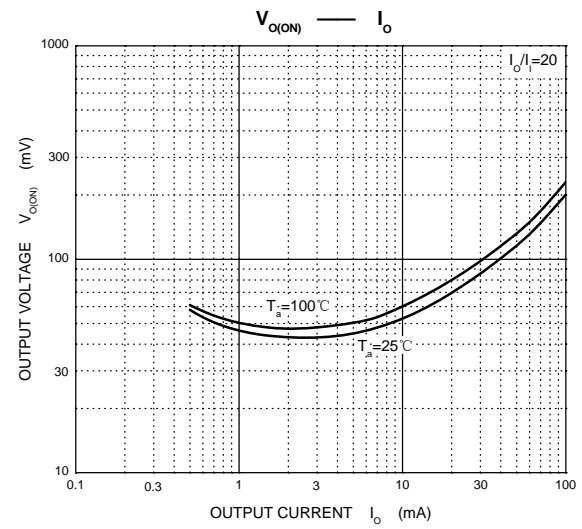
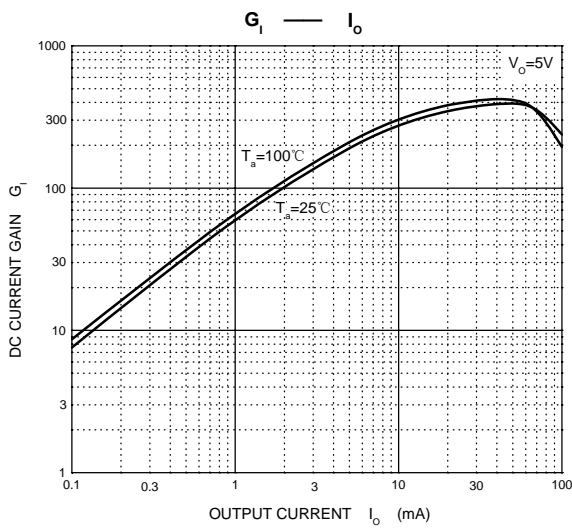
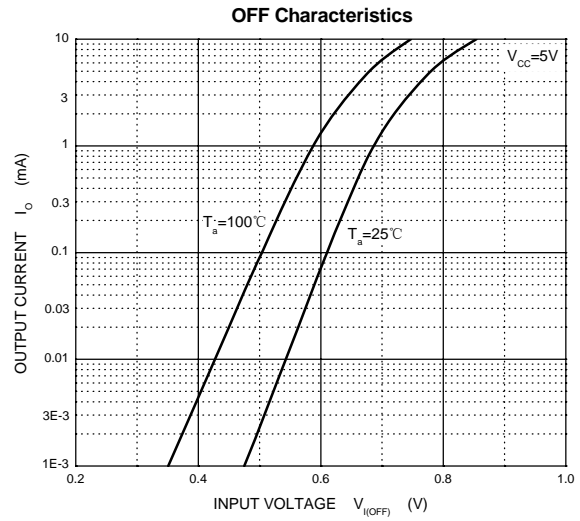
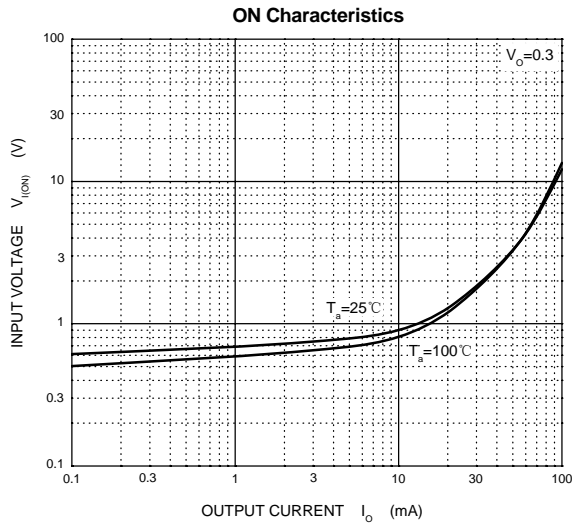

Soldering parameters

Reflow Condition		Pb-Free assembly (see as below)
Pre Heat	-Temperature Min ($T_{s(min)}$)	+150°C
	-Temperature Max($T_{s(max)}$)	+200°C
	-Time (Min to Max) (ts)	60-180 secs.
Average ramp up rate (Liquid us Temp (T_L) to peak)		3°C/sec. Max
$T_{s(max)}$ to T_L - Ramp-up Rate		3°C/sec. Max
Reflow	-Temperature(T_L)(Liquid us)	+217°C
	-Temperature(t_L)	60-150 secs.
Peak Temp (T_P)		+260(+0/-5)°C
Time within 5°C of actual Peak Temp (t_p)		30 secs. Max
Ramp-down Rate		6°C/sec. Max
Time 25°C to Peak Temp (T_P)		8 min. Max
Do not exceed		+260°C



Package Dimensions & Suggested Pad Layout

SOT23

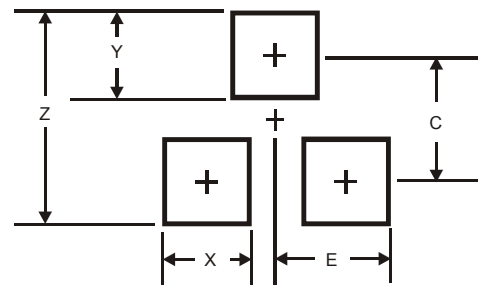
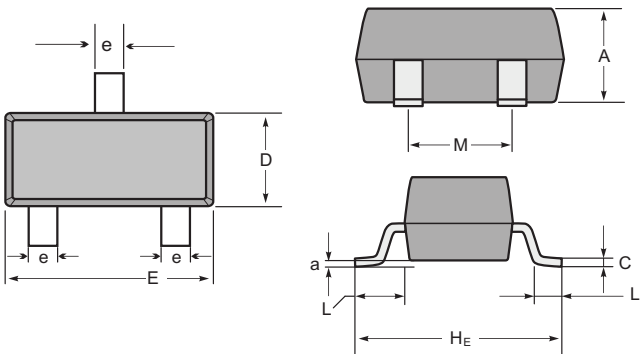

SOT-23 mechanical data

UNIT	A	C	D	E	He	e	M	L	L1	a	
mm	max	1.1	0.15	1.4	3.0	2.6	0.5	1.95	0.55 (ref)	0.36 (ref)	0.0
	min	0.9	0.08	1.2	2.8	2.2	0.3	1.7			0.15
mil	max	43	6	55	118	102	20	77	22 (ref)	14 (ref)	0.0
	min	35	3	47	110	87	12	67			6

Dimensions	SOT23
Z	2.9
X	0.8
Y	0.9
C	2.0
E	1.35

Tape & reel specification

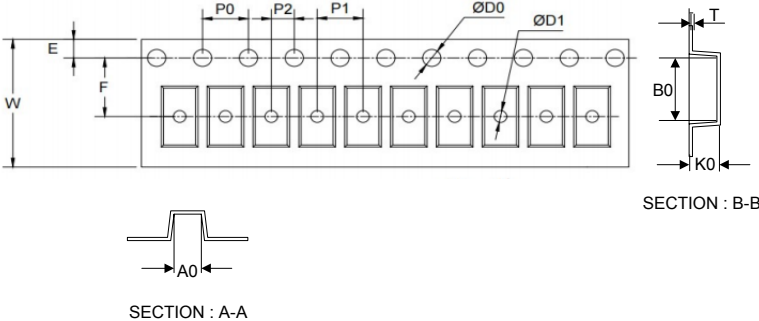
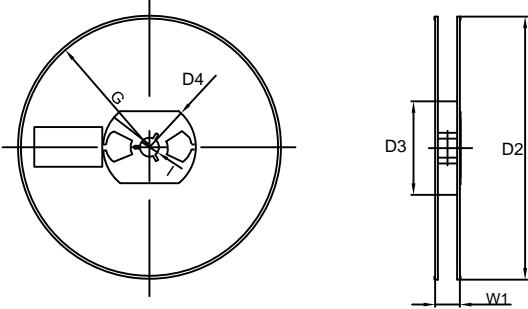
Tape	Symbol	Dimension (mm)	
	P0	4.00±0.10	
	P1	4.00±0.10	
	P2	2.00±0.10	
	D0	1.55±0.10	
	D1	1.05±0.10	
	E	1.55±0.10	
	F	3.60±0.10	
	W	8.00±0.10	
	A0	3.80±0.20	
	B0	3.25±0.20	
	K0	1.45±0.10	
	T	0.25±0.05	
	<p>7" Reel</p> 	D2	178.0±3.0
		D3	55Min.
		D4	R24.0±3.0
G		R82.0±3.0	
I		13.0±2.0	
W1		11.0±3.0	
Quantity: 3000PCS			