

12	13	14	15
MAPX	MODIFICATION	DATE	DRAW

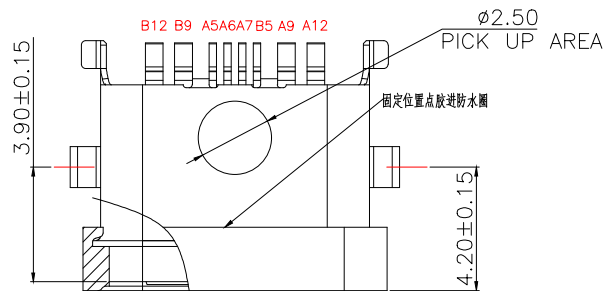

SECTION: B-B

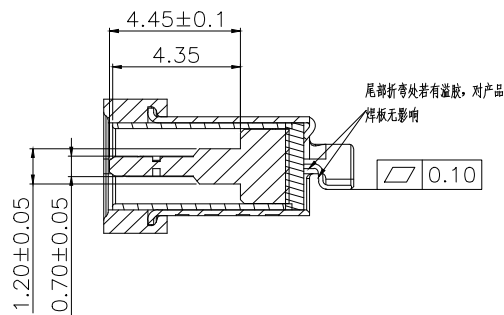
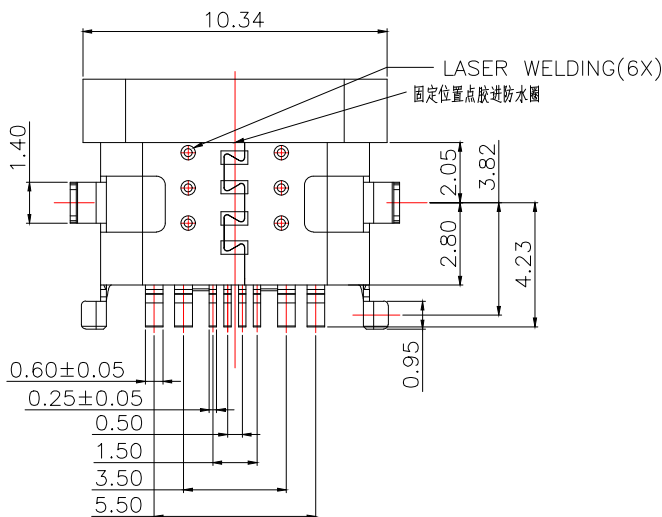
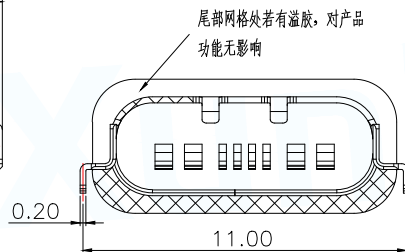
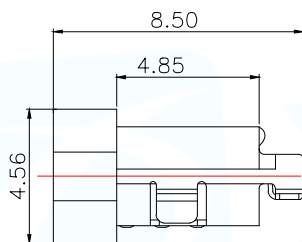
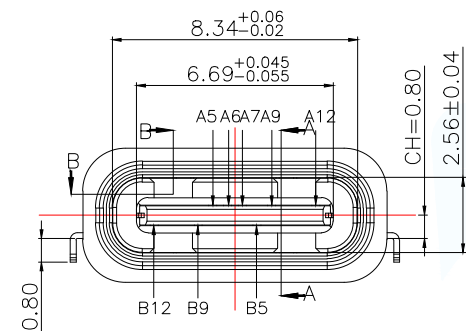
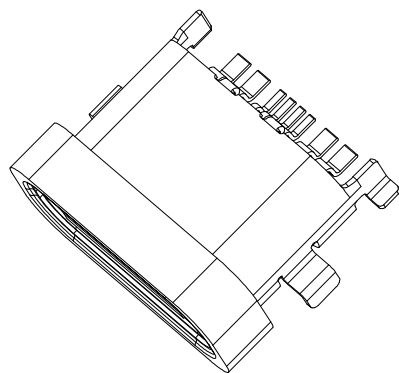

SECTION: A-A

NOTE:

- MATERIAL SPECIFICATION:
 - HOUSING: HIGH TEMPERATURE RESISTANT PLASTIC, UL94 V-0.
 - TERMINAL: COPPER ALLOY
 - MID PLATE: STAINLESS STEEL
 - INNER SHELL: STAINLESS STEEL
 - OUT SHELL: STAINLESS STEEL
 - GLUE: EPOXY
 - O-RING: GLUE
- PLATING SPECIFICATION:
 - TERMINAL:
 - PLATING NICKEL 50u" MIN. OVER ALL.
 - Au G/F PLATED ON CONTACT AREA.
 - SN PLATED ON SOLDERING AREA.
 - OUT SHELL:
 - PLATING NICKEL 50u" MIN. OVER ALL.
 - INNER SHELL & MID PLATE:
 - CLEAR ONLY
- MECHANICAL PERFORMANCE,
 - INSERTION FORCE: 0.5~2.0kgf.
 - REMOVAL FORCE: 0.8kgf~2.0kgf.
 - DURABILITY: 10000 CYCLES.
- ELECTRICAL PERFORMANCE,
 - VOLTAGE RATING: 5 V DC/AC (RMS. max)
CURRENT RATING: 3 AMPS. FOR TOTAL VBUS/GND PINS;
1.25AMPS FOR CC PIN, 0.25 AMPS. FOR ALL OTHER CONTACT.
 - LLCR:
 - VBUS & GND PINS AND OTHER PINS: 40mA/PIN MAX.
 - LLCR MAX. CHANGE OF ALL PINS: 10mA.
 - INSULATION RESISTANCE: 100MΩ MIN
 - DIELECTRIC WITHSTAND VOLTAGE, AC 100V FOR 1 MINUTE.
- ENVIRONMENTAL PERFORMANCE:
 - OPERATING TEMPERATURE: -40°C~+85°C.
- IR REFLOW:
 - THE PEAK TEMPERATURE ON THE BOARD SHALL BE MAINTAINED FOR 10 SECONDS AT 260°C.
- WATERPROOF: IPX5

MANUFACTURE DWG		东莞市讯普电子科技有限公司 DongGuan XunPu Electronics Co., Ltd	
UNLESS OTHERWISE SPECIFIED TOLERANCES			TITLE: USB TYPE C 8pos CH=0.80 R/A WATERPROOF
			PAR TYPE-C-801-WFRX5SC080
DECIMALS:	ANGLES:		DWN Lucas
.X: ±0.30	X.: ±10'		CHKD Ethan
.XX: ±0.20	X.X': ±8'	APVD Jacob	SCALE 1:1 UNIT: MM
.XXX: ±0.10	X.XX': ±5'	CUSTOMER COPY	SIZE: A4 SHEET: 1F3 REV: A

USB TYPE-C PIN ASSIGNMENTS

PIN NUMBER	SIGNAL NAME	PIN NUMBER	SIGNAL NAME
A1		B12	GND
A2		B11	
A3		B10	
A4		B9	VBUS
A5	CC1	B8	
A6	D+	B7	
A7	D-	B6	
A8		B5	CC2
A9	VBUS	B4	
A10		B3	
A11		B2	
A12	GND	B1	

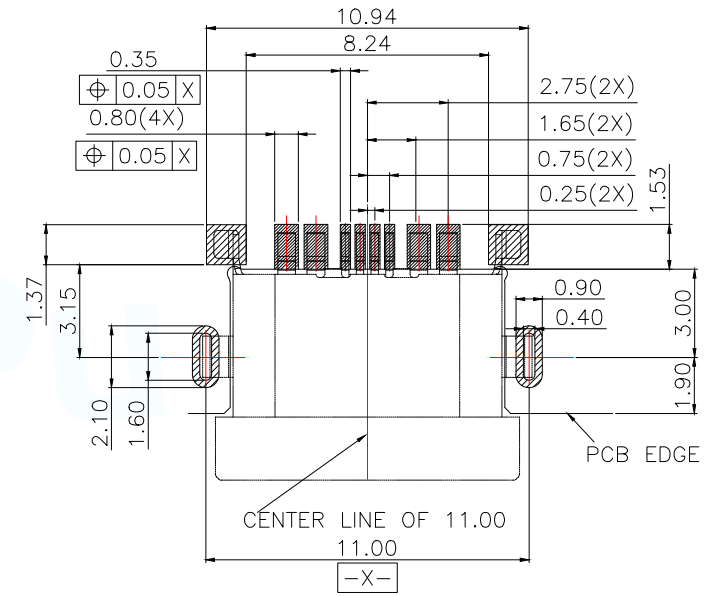
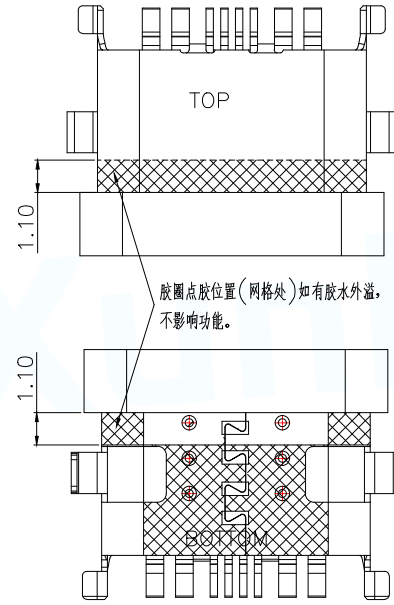

RECOMMENDED OPENING DIMENSIONS OF CASE MATING AREA WITH SEALING RING

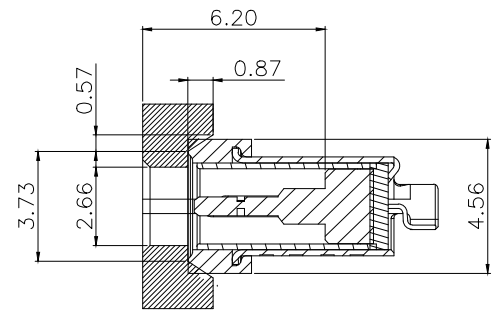
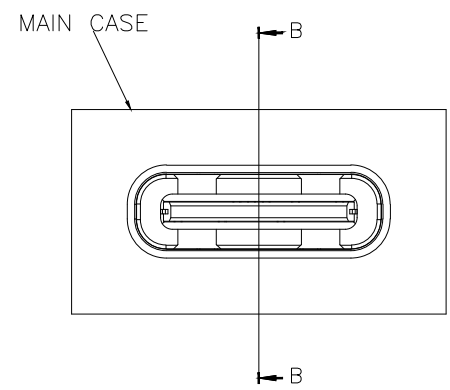

MANUFACTURE DWG		 东莞市讯普电子科技有限公司 DongGuan XunPu Electronics Co.,Ltd	
UNLESS OTHERWISE SPECIFIED TOLERANCES			TITLE:USB TYPE C 8pos CH=0.80 R/A WATERPROOF
DECIMALS:	ANGLES:		PAR TYPE-C-801-WFRX5SC080
.X:±0.30	X.':±10'		DWN Lucas
.XX:±0.20	X.X':±8'		CHKD Ethan
.XXX:±0.10	X.XX':±5'	CUSTOMER COPY	APVD Jacob
		SCALE:1:1	UNIT:MM
		SIZE:A4	UNIT:MM
		SHEET:2F3	REV:A

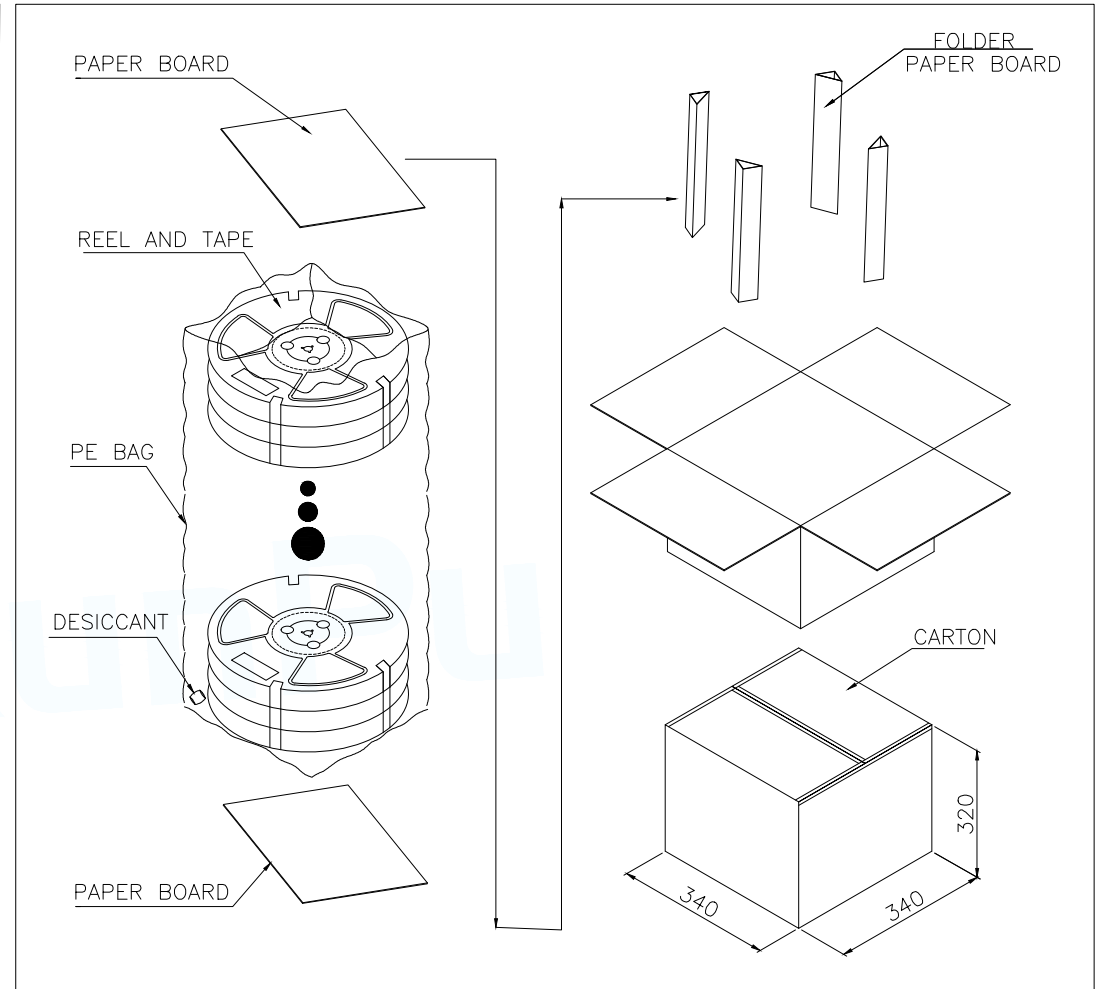
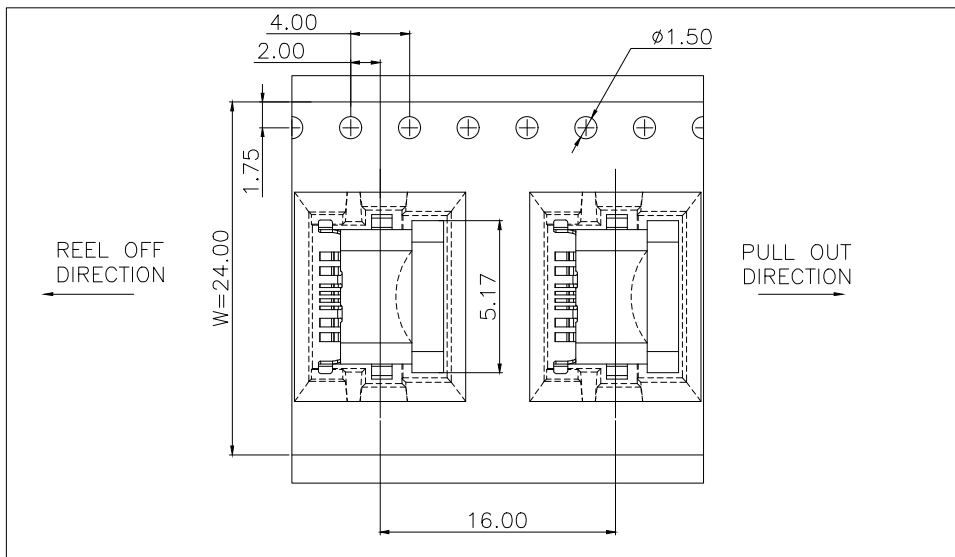
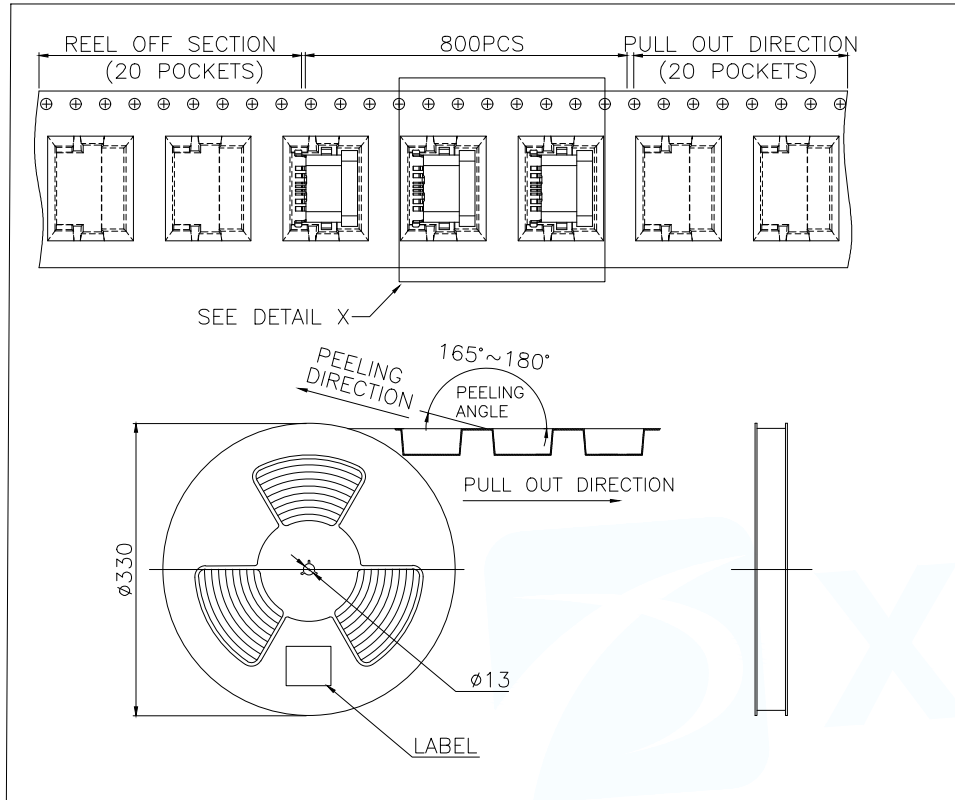

		REEL	CARTON
CONNECTOR (PCS)		800	8000
MANUFACTURE DWG	东莞市讯普电子科技有限公司 DongGuan XunPu Electronics Co.,Ltd		
UNLESS OTHERWISE SPECIFIED TOLERANCES		TITLE:USB TYPE C 8pos CH=0.80 R/A WATERPROOF	
		PAR	TYPE-C-801-WFRX5SC080
DECIMALS:	ANGLES:	DWN	Lucas
.X:±0.30	X.':±10'	CHKD	Ethan
.XX:±0.20	X.X':±8'	APVD	Jacob
.XXX:±0.10	X.XX':±5'	SCALE 1:1	UNIT:MM
		CUSTOMER COPY	SIZE:A4 SHEET:3F3 REV:A