

NOTE:

1.MATERIAL SPECIFICATION:

- 1.HOUSING:HIGH TEMPERATURE RESISTANT PLASTIC
- 2.TERMINAL: COPPER ALLOY
- 3.MID PLATE: STAINLESS STEEL
- 4.FRONT SHELL: STAINLESS STEEL
- 5.O-RING: SILICA GEL, BLACK
- 6.GLUE:EPOXY,BLACK

2.PLATING SPECIFICATION:

- 2-1.TERMINAL:
Ni 50u" MIN. UNDER PLATED OVER ALL.
Au 3u" PLATED ON THE CONTACT AREA.
Au G/F PLATED ON THE SOLDER AREA.

2-2. SHELL:

- Ni 50u" MIN. UNDER PLATED OVER ALL.

2-3.MID PLATE:

- CLEAR ONLY

3.MECHANICAL PERFORMANCE,

- 3-1.INSERTION FORCE: 0.5~2.0kgf.
- 3-2.REMOVAL FORCE: 0.8kgf~2.0kgf.
- 3-3.DURABILITY: 10000 CYCLES.

4.ELECTRICAL PERFORMANCE,

- 4-1. VOLTAGE RATING: 5V.
CURRENT RATING: 5A.
- 4-2. LLCR:
VBUS & GND PINS AND OTHER PINS: 40mA/PIN MAX.
LLCR MAX. CHANGE OF ALL PINS: 10mA.
- 4-3.INSULATION RESISTANCE: 100MΩ MIN
- 4-4.DIELECTRIC WITHSTAND VOLTAGE,AC 100V FOR 1 MINUTE.

5. ENVIRONMENTAL PERFORMANCE:

- OPERATING TEMPERATURE: -40°C~+85°C.

6.IR REFLOW:

- THE PEAK TEMPERATURE ON THE BOARD SHALL BE MAINTAINED FOR 10 SECONDS AT 260°C.

7.WATERPROOF:IPX5

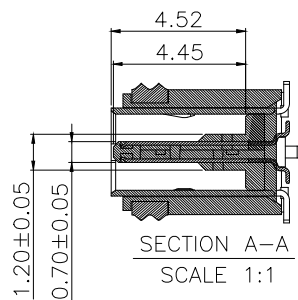
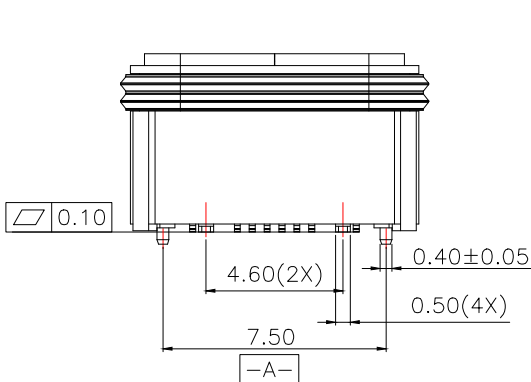
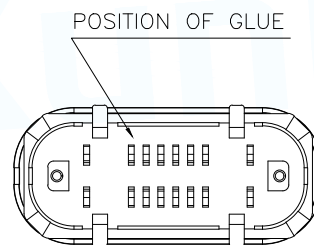
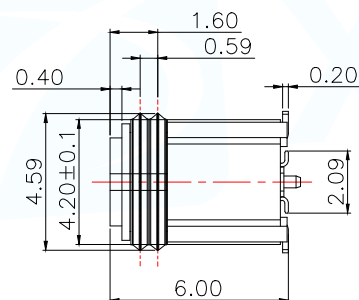
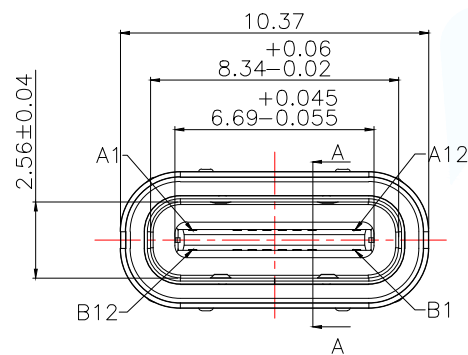

MANUFACTURE DWG		东莞市讯普电子科技有限公司 DongGuan XunPu Electronics Co.,Ltd	
UNLESS OTHERWISE SPECIFIED TOLERANCES			TITLE:USB TYPE C 16pos VERTIACL H=6.0mm IPX5
DECIMALS:	ANGLES:		PAR TYPE-C-631S-LSC5H060
.X:±0.30	X.':±10'		DWN Lucas
.XX:±0.20	X.X':±8'		CHKD Ethan
.XXX:±0.10	X.XX':±5'	SCALE:1:1	UNIT:MM
CUSTOMER COPY		SIZE:A4	SHEET:1F3
			REV:A

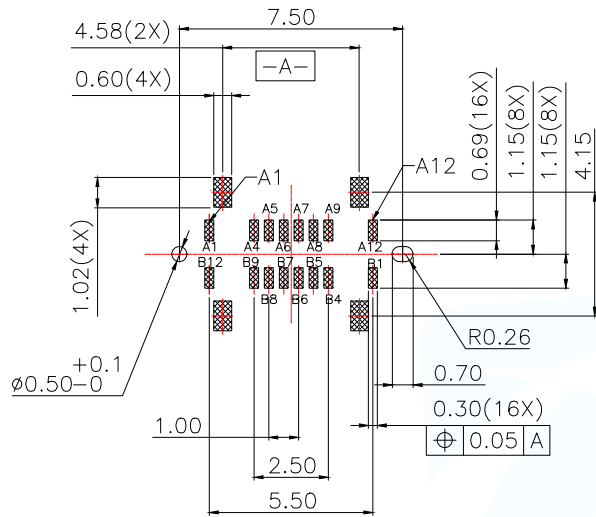

RECOMMENDED PCB LAYOUT(TOP VIEW)
THICKNESS 0.8±0.10MM;DEFAULT TOLERANCE:±0.05

USB TYPE-C PIN ASSIGNMENTS

A1	A2	A3	A4	A5	A6	A7	A8	A9	A10	A11	A12
GND			VBUS	CC1	D+	D-	SBU1	VBUS			GND
GND			VBUS	SBU2	D-	D+	CC2	VBUS			GND
B12	B11	B10	B9	B8	B7	B6	B5	B4	B3	B2	B1

THERE IS SOME GLUE ON THE MAKE AREA(MAY BE)
IT IS NOT AFFECT SOLDERING

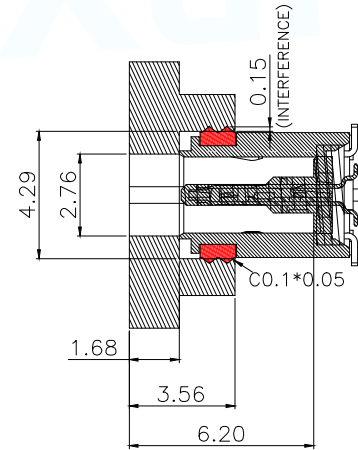
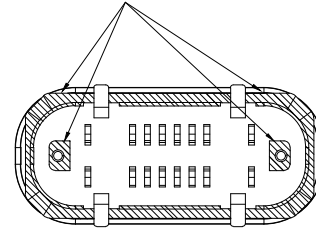

RECOMMENDED OPENING DIMENSIONS
OF CASE MATING AREA WITH SEALING RING

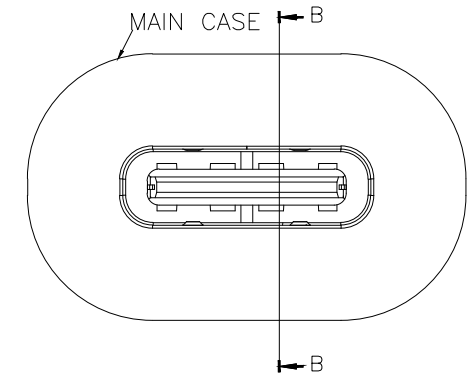
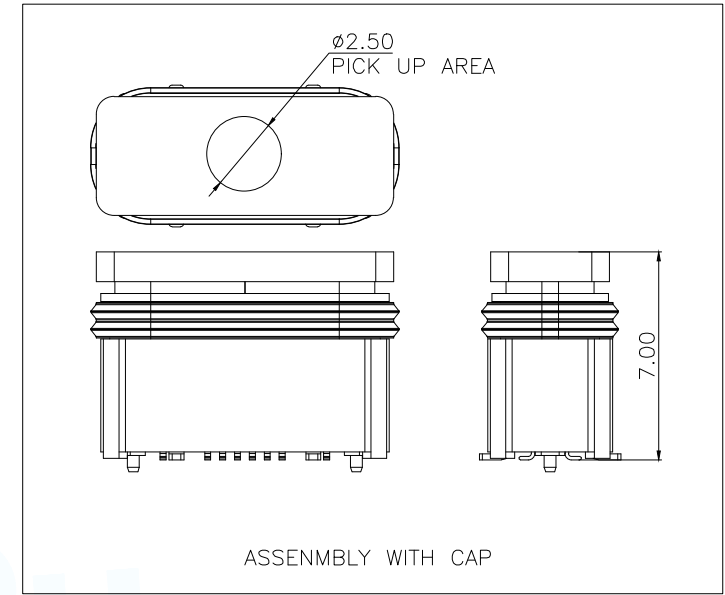

MANUFACTURE DWG		东莞市讯普电子科技有限公司 DongGuan XunPu Electronics Co.,Ltd	
UNLESS OTHERWISE SPECIFIED TOLERANCES			TITLE:USB TYPE C 16pos VERTIACL H=6.0mm IPX5
DECIMALS:	ANGLES:		PAR TYPE-C-631S-LSCX5H060 DWN Lucas
.X:±0.30	X.:±10°		CHKD Ethan APVD Jacob
.XX:±0.20	X.X':±8°		SCALE1:1 UNIT:MM SIZE:A4 SHEET:2F3 REV:A
.XXX:±0.10	X.XX':±5°	CUSTOMER COPY	

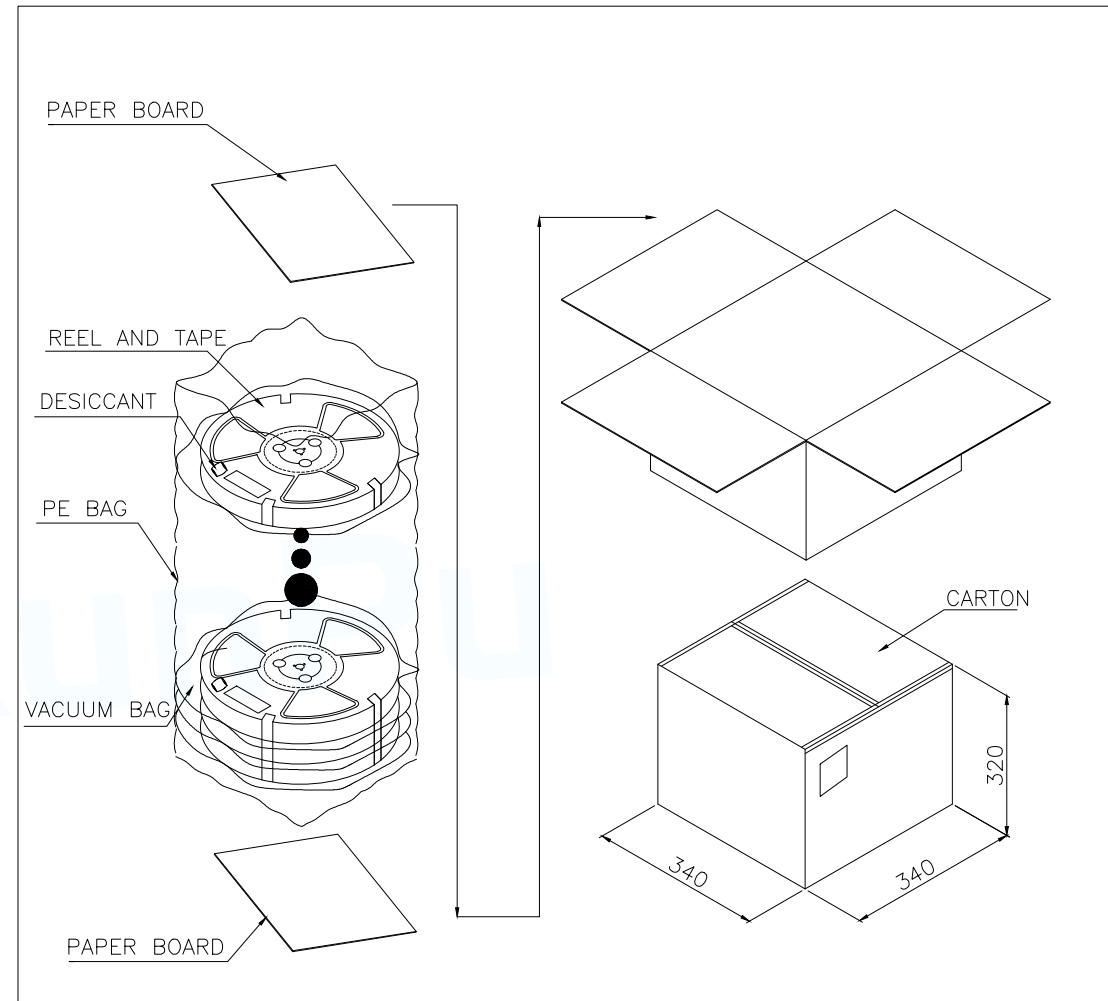
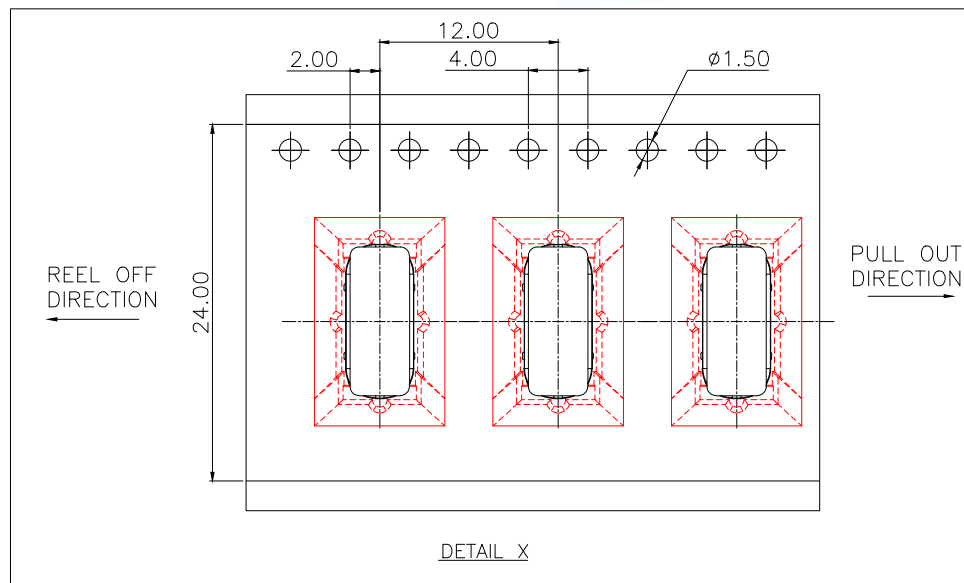
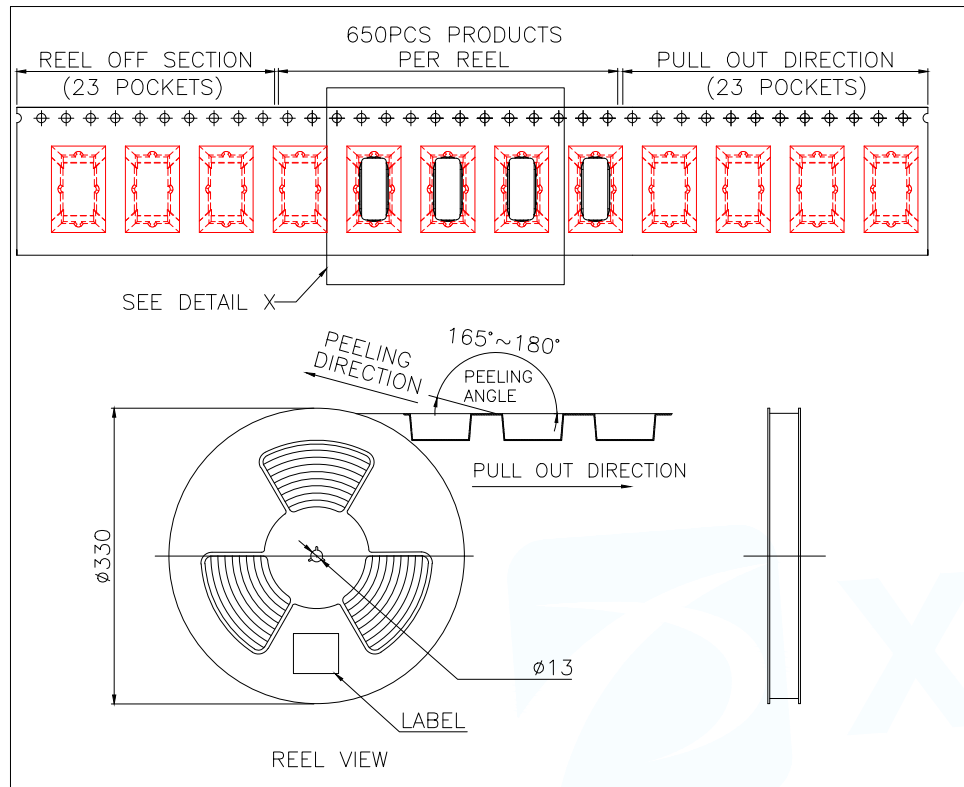

		REEL/TRAY	CARTON
CONNECTOR (PCS)		650	6500
MANUFACTURE DWG	东莞市讯普电子科技有限公司 DongGuan XunPu Electronics Co.,Ltd		
UNLESS OTHERWISE SPECIFIED TOLERANCES		TITLE:USB TYPE C 16pos VERTIACL H=6.0mm IPX5	
		PAR	TYPE-C-631S-LSCX5H060
DECIMALS:	ANGLES:	DWN	Lucas
.X:±0.30	X.':±10°	CHKD	Ethan
.XX:±0.20	X.X':±8°	APVD	Jacob
.XXX:±0.10	X.XX':±5°	SCALE 1:1	UNIT:MM
	CUSTOMER COPY	SIZE:A4	SHEET:3F3
			REV:A