

产品规格书

SAP料号 SAP part No. :	10201T6112A50002A0
产品型号 Product P/N :	SK6112-RG-002
样品号 SAP part No. :	OP00211B-001
客户料号 Client P/N :	NA
版本号 Version No.:	B/2
时间 Sending Date :	2025-11-20

Customer approval			Opsco approval		
CHECK	APPROVE	CONFIRM	DRAW	CHECK	APPROVE
			张维友	周凯	朱更生
Stamp			Stamp		



*使用我司产品前, 请检索我司官网核对规格书版本, 产品规格书版本更新, 恕不能及时相告, 请以官网最新资料为准。
 *Before using our products, please search our official website to verify the version of the specification sheet. The product specification sheet version is updated, and we apologize for any inconvenience caused. Please refer to the latest information on the official website for accuracy.
 *该版权及产品最终解释权归东莞市欧思科光电科技有限公司所有, 如有特殊规格要求, 请联系我司工程人员。
 *The copyright and final interpretation rights of the product belong to Dongguan OPSCO Optoelectronic Technology Co., Ltd. If there are special specification requirements, please contact our engineering personnel.

目 录 Catalogue

1、产品概述 Overview	3
2、主要应用 Main applications	3
3、产品命名一般说明 General instructions for product naming	4
4、机械尺寸 Mechanical dimensions	4
5、引脚功能说明 Pin Function Description	4
6、PCB建议焊盘尺寸 PCB recommended pad size	5
7、IC极限参数 IC limit parameter	5
8、GRB LED光电参数 GRB LED Optoelectronic parameters	6
9、IC电气参数 IC electrical parameters	6
10、控制器建议数据传输时间 Controller suggested data transmission time.....	7
11、数据传输方式 Data transmission method	8-17
12、光电特性 Photoelectric characteristic	18
13、包装标准 Packaging standards	19
14、可靠性测试 Reliability testing	20

1.产品概述 Product overview:

- 工作电压: 5V@12mA(OUT GRB) ;

Forward voltage: 5V@12mA (OUT GRB) ;

- 12mA电流版本应用注意事项:

Precautions for the application of the 12mA current version

- 1.当点亮单色光时, 可100%灰阶使用;

When monochromatic light is lit, it can be used in 100% grayscale;

- 2.当点亮三色光时, 70%灰阶使用;

When illuminating the tricolor light, use 70% grayscale;

- 发光角度: 120°;

Luminescent angle: 120° ;

- 胶体颜色: 半透明;

Lens color: translucent ;

- 内置复位电路, 上电不亮灯;

Built-in reset circuit, power does not light ;

- 灰度调节: 256级;

Grayscale adjustment: 256 levels ;

- Gen 2 产品支持高级设置模式:

Gen 2 product support high level mode:

1. 链路回传功能; feedback mode ;

2.电流增益: 32阶; current gain adjustment: 32 levels ;

3.PWM 1.2-20KHz可调, 默认: 20KHz ; PWM 1.2-20KHz adjustment, default: 20KHz;

4.睡眠模式, 睡眠模式下静态电流: 5uA; Sleep mode, static current in sleep mode: 5uA ;

5.支持多路并联, 最多15路; Supports multiple parallel connections, up to 15 channels;

6.支持动态、固定ID; Supports dynamic/fixed ID ;

- 单线归零码传输协议, 可无限级联;

Single-line zero code transmission protocol, can be infinite cascade;

- 数据传输频率可达800Kbps, 当刷新速30帧/秒时, 级联数小于1024点;

The data transmission frequency can reach 800Kbps, and when the refresh speed is 30 frames per second, the cascade number is less than 1024 points. ;

- 湿敏等级: 5a;

MSL: 5a ;

- 静电ESD: 2KV;

ESD level: 2KV ;

- 符合RoHS REACH;

RoHS and REACH-compliant;

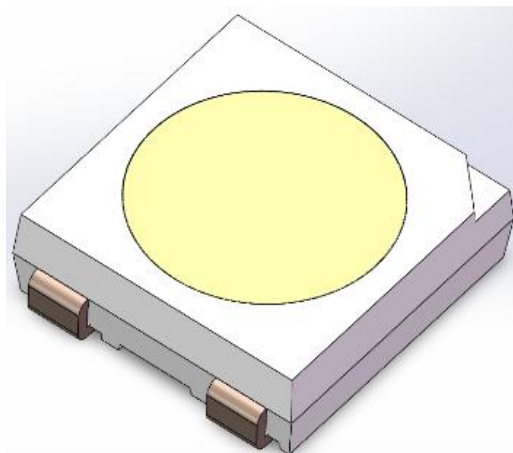

2.主要应用 Main applications:

- 消费电子产品

consumer electronics

3. 产品命名一般说明 General instructions for product naming:

SK 6112-RG-002

① ② ③

①	②	③
系列 Series	IC系列与电流代码 IC series and current codes	内部编码 Internal code
默认为GRB晶片与 IC集成在一起 Default to GRB chip integrated with IC	6112:指6112系列IC,12mA电流版本 Refers to the 6112 series IC,12mA current version	RG-002:流水号 Serial number

4. 机械尺寸 Mechanical dimensions:

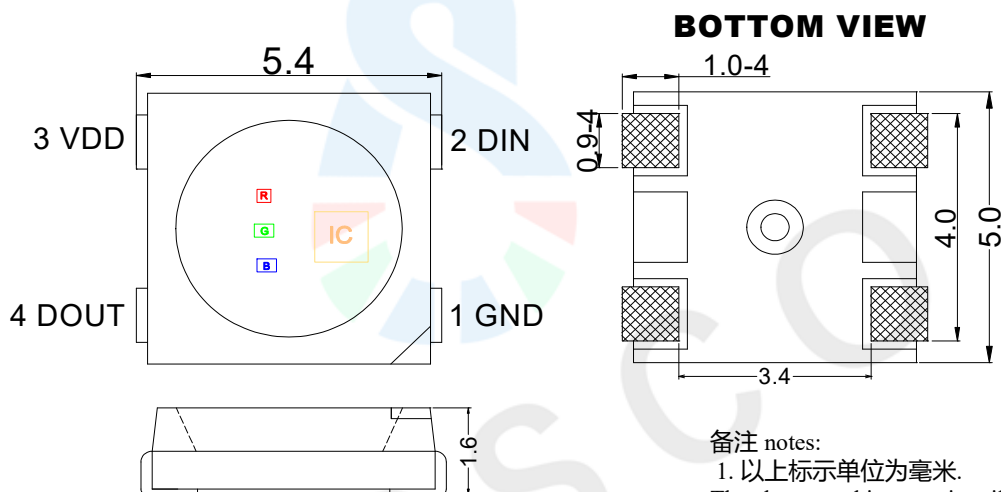

备注 notes:

1. 以上标示单位为毫米。
The above markings are in millimeters
2. 除非另外注明, 尺寸公差为 ± 0.1 毫米。
Unless otherwise specified, the dimensional tolerance is ± 0.1 millimeters

5. 引脚功能说明 Pin Function Description:

序号 Serial Number	符号 Symbol	管脚名 Pin name	功能描述 Function Description
1	GND	地 Grounds	电源接地 Power grounding
2	DIN	数据输入 Data input	控制数据信号输入 Control data signal input
3	VDD	电源 Power supply	供电管脚 Power supply pins
4	DOUT	数据输出 Data output	控制数据信号输出 Control data signal output

6.PCB建议焊盘尺寸 PCB recommended pad size:

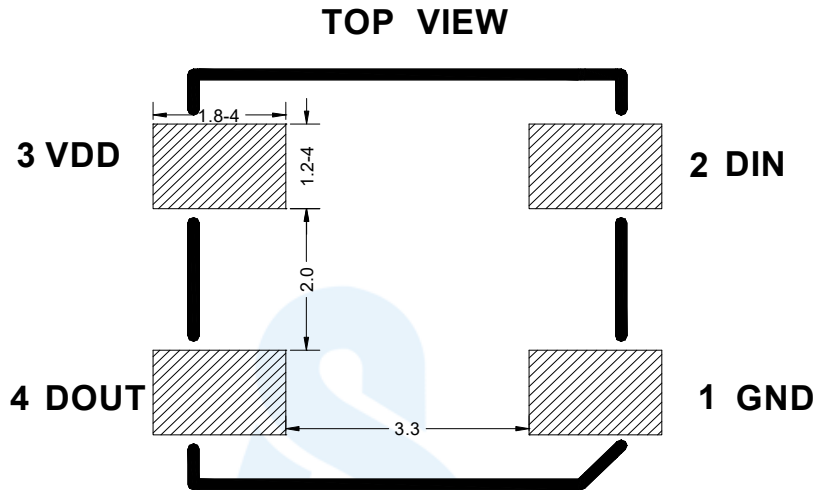

7.IC极限参数 IC limit parameter : (Ta=25°C)

参数 Parameter	符号 Symbol	范围 Range	单位 Unit
逻辑电源电压 Working voltage	V _{in}	-3.7~5.5	V
工作温度 Operation temperature	T _{opt}	-40~80	°C
储存温度 Storage temperature	T _{stg}	-40~+80	°C
ESD耐压 (人体模式) ESD withstand voltage (human mode)	V _{ESD}	2K	V

8. GRB LED 光电参数 Optoelectronic parameters:

颜色 Colour	SK6112-RG-002 12mA	
	波长 (nm) Wavelength (nm)	亮度 (mcd) Brightness (mcd)
绿色 (GREEN)	520-530	815-1275
红色 (RED)	615-625	320-580
蓝色 (BLUE)	465-475	200-385

注: 亮度误差±10%, 波长误差±1.0nm

Note:Luminous Intensity: ±10%lv, Dominant Wavelength: ±1.0nm

9. IC电气参数 IC electrical parameters: (TA=25°C)

参数 Parameter	符号 Symbol	最小 Minimum	典型 Typical	最大 Maximum	单位 Unit	测试条件 Test conditions
工作电压 Chip input voltage	VDD	3.7	5	5.5	V	---
信号输入翻转阈值 Signal input flip threshold	VIH	0.65*VDD	---	VDD+0.4	V	---
	VIL	---	---	0.2*VDD	V	
信号输出翻转阈值 Signal output flip threshold	VOH	4.4			V	---
	VOL			0.3	V	
G/R/B输出驱动电流 G/R/B output drive current	IDOUT	11.5	13.5	15.5	mA	VDD- VfLED ≥ 1.2V
PWM频率 PWM frequency	FPWM			20	KHz	---
工作功耗 Operation Current	IDD	---	0.5	0.75	mA	G、R、B no load
静态电流 B、G、R off leakage current	Iff	---	---	1	uA	PWM=0(off), @B、G、R =5V
动态功耗电流 Input leakage	Ileak	---	---	1	uA	DIN=0V
数据传输速率 Transfer rate	FDIN	---	800	---	Kbps	---

11.数据传输方式 Data transmission method: (Ta=25°C)

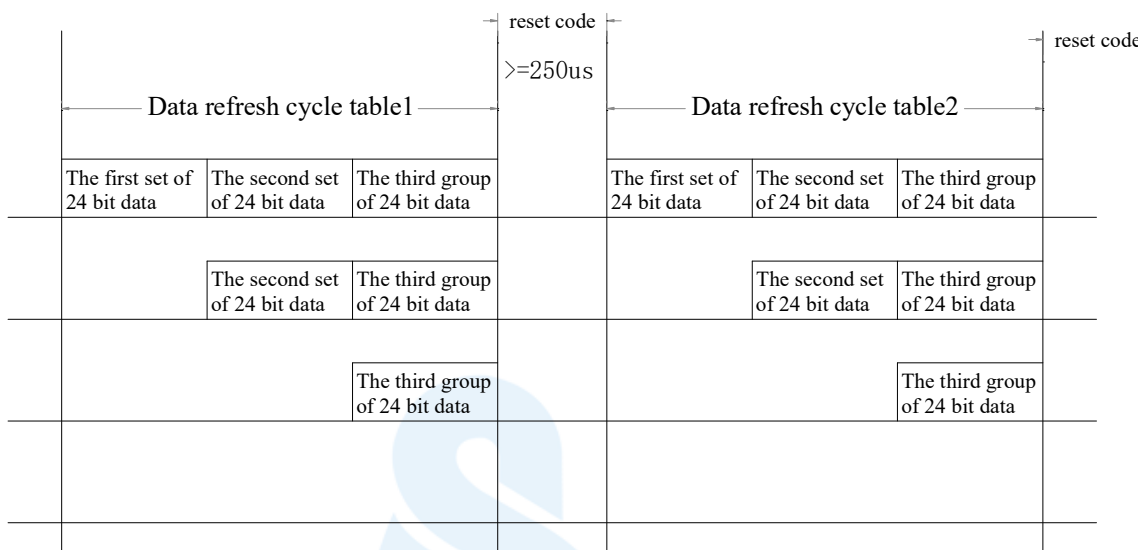

注Note: 其中D1为MCU端发送的数据, D2、D3、D4为级联电路自动整形转发的数据。

Among them, D1 is the data sent by the MCU end, and D2, D3, and D4 are the data automatically shaped and forwarded by the cascaded circuit.

1.高阶工作模式 (回传模式和高级设置模式) Advanced Function Mode (feedback mode and high level setup mode)

主机MCU可以发出特殊命令, 使SK6112进入高级功能模式。在高级模式下, SK6112支持双向数据传输。通过单线协议, SK6112可以反馈有关LED的级联数量或R/G/B通道在LED灯带到MCU。出于调光目的, SK6112还具有电流增益用于条带上每个单个LED的单个R/G/B通道的控制功能。还提供可编程PWM刷新率。

A host MCU can issue special commands to make SK6112 get into advanced function mode. In the advanced mode, SK6112 supports bi-direction data transfer. Through the single wire protocol, SK6112 can feedback the information about the cascaded number of LEDs or maximal sink current capability of R/G/B channel on the LED lamp strip to MCU. For dimming purpose, SK6112 also features the current gain control function for the individual R/G/B channel for every single LED on the strip. Programmable PWM refresh rate is also available.

2.1状态回传模式开启 Status feedback mode activation

命令格式Trst+Th50 Command format Trst+Th50

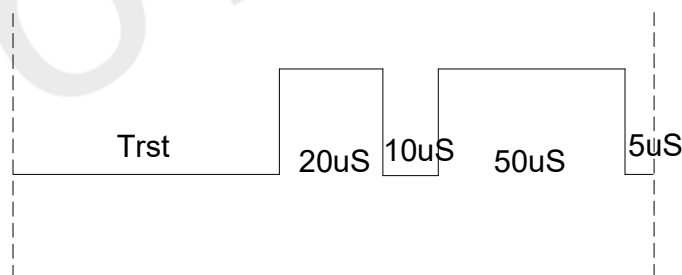

Th50 时序要求: 上图时序上显示之脉波时间为典型值, 上、下限值为脉波宽度值 $\pm 20\%$ 。

Timing and waveform of Th50: the pulse width shown as above stands for the typical data, the maximal or minimal value should be controlled within the typical data $\pm 20\%$.

工作原理 Setup

系统上电后, MCU通过GPIO发出Trst+Th50命令端口。命令结束时, MCU必须更改输出的GPIO端口属性模式切换到输入模式以等待SK6112返回的信号。一次SK6112识别Trst+Th50命令被识别, 它将进入反馈功能通过将GPIO功能从输入模式切换到Din的输出从正常模式切换到模式, 以及Dout从输出模式到输入模式。然后SK6112等待10us并生成Din端口上宽度为“Trev”的正脉冲, 返回MCU GPIO端口或Dout前代SK6112的端口(详细波形如下所示)。如果SK6112在Dout端口上接收到一个“Trev”波形, 它也会生成一个“Trev”Din端口上的波形。“Trev”波形的间隔为80us。因此MCU接收到的“Trev”波形表示上SK6112芯片的数量LED灯带。

当SK6112或MCU在160us内没有接收到任何“Trev”脉冲时, SK6112或MCU将退出反馈模式, 返回正常功能模式。MCU然后可以确定以下信息:

- a. LED灯条上级联的SK6112的数量。
- b. “Trev”波形中的高脉冲宽度表示SK6112中G/R/B通道的最大吸收电流(12mA吸收电流为20us高脉冲, 5mA为10us高脉冲)
 示例: 例如, 下图是针对12mA通道电流

After system power-on, the MCU issues the Trst+Th50 command through a GPIO port. While the command ends, MCU must change the GPIO port attribute from output mode to input mode to wait for signal returned from SK6112. Once SK6112 recognizing the Trst+Th50 command is recognized, it will enter into feedback function mode from normal mode by switching GPIO function from input mode to output for Din, and from output to input mode for Dout. Then SK6112 waits for 10us and generates a positive pulse with width “Trev” on Din port, either back to MCU GPIO port or to the Dout port of the predecessor SK6112 (the detailed waveform is shown as below). If SK6112 receives a “Trev” waveform on Dout port, it will also generate a “Trev” waveform on Din port. The interval of a “Trev” waveform is 80us. Hence, the number of “Trev” waveforms received by the MCU represents the number of SK6112 chips on the LED strip.

While SK6112 or MCU does not receive any “Trev” pulse within 160us, SK6112 or MCU will get out of feedback mode and go back to normal function mode. MCU may then determine the following information:

- a. the number of cascaded SK6112’s on the LED strip.
- b. the high pulse width in the “Trev” waveform denotes the maximum sink current of the G/R/B channel in SK6112 (20us high pulse for 12mA sink current, 10us for 5mA) .

Example : as an example, the following diagram is for 12mA channel current

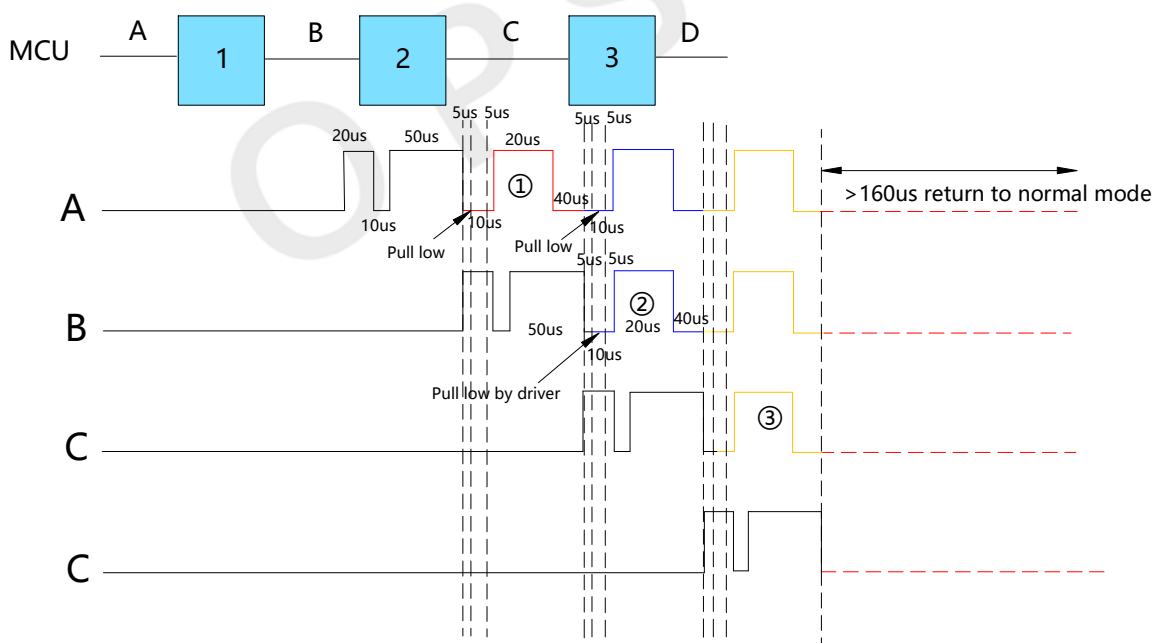

局部放大图 Partial Enlarged Image

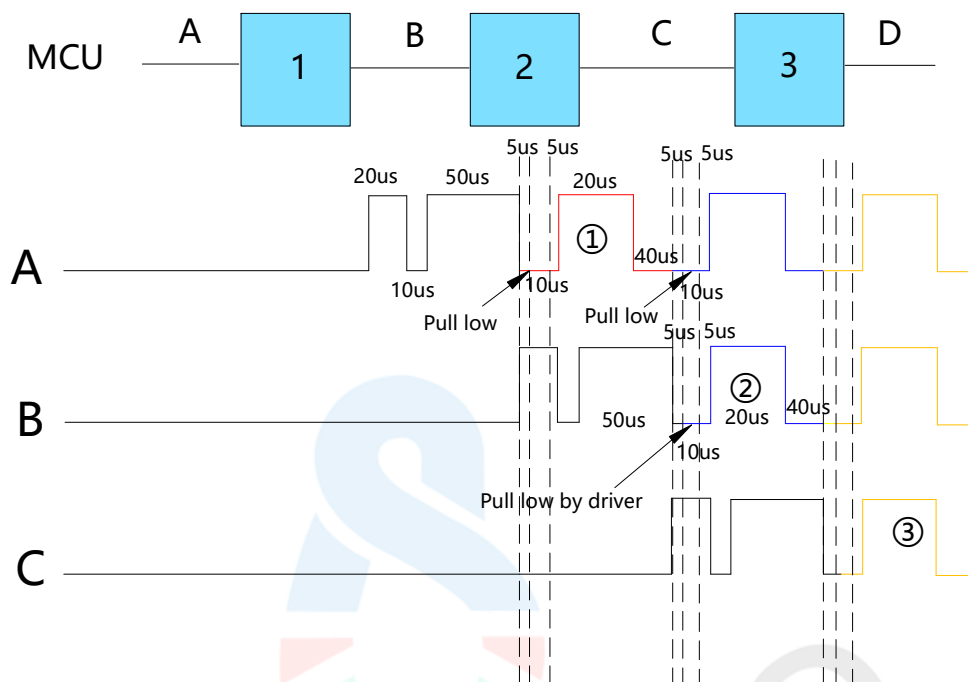

2.2、高阶工作模式显示数据编码 High order working mode display data encoding

高阶工作模式设置数据(setup mode) Advanced working mode setting data (setup mode)

高级设置模式中的数据格式 (24位) 与正常模式中的相同。请注意, “高级设置模式” 可以在需要时启用。

The data format (24 bits) in high level setup mode is the same as in normal mode. Note that the “High Level Setup mode” can be enabled whenever needed.

波形和格式 Waveform and format:

Th20+Trst+24位第一芯片数据+24位第二芯片数据+...+首先传输具有MSB位的第N个芯片的24位数据。

Th20+Trst+24bits data of 1st chip+ 24bits data of 2nd chip+...+ 24bits data of Nth chip with MSB bit transferred first.

	250us	20us	250us	250us	
Data bits s stream for normal display mode or high level setup mode	Trst	Th20	Trst	Data bits for high level setup mode	Data bits for high level setup mode	Trst

设置Th20的时间: Timing to setup Th20:

Th20可以在正常显示功能的数据位被传输之后或者在启用高级设置模式的命令之后发出。

Th20 can be issued after the data bits of a normal display function are transferred or after the command of enabling high level setup mode.

电流增益 current gain

在高阶模式设置下, 可针对G、R、B 端口之最大流入电流进行增益调节, 电流增益计算公式: (以调节G 的端口为例)

In high-order mode settings, gain adjustment can be performed for the maximum inflow current of ports G, R, and B. The current gain calculation formula is: (Taking the port for adjusting G as an example)

$$I_o = I_m * (15.5 + 0.5 * G[0] + 1 * G[1] + 2 * G[2] + 4 * G[3] + 8 * G[4]) / 31$$

$I_m = 5\text{ma}$ or 12MA

默认状态下 (In default state) , $G <4:0> = 1\text{F}$; $R <4:0> = 1\text{F}$; $B <4:0> = 1\text{F}$;

S23	S22	S21	S20	S19	S18	S17	S16	S15	S14	S13	S12	S11	S10	S09	S08	S07	S06	S05	S04	S03	S02	S01	S00
SS	SS	0	G	G	G	G	G	SS	SS	SS	R	R	R	R	R	SS	SS	SS	B	B	B	B	B
<5>	<4>		<4>	<3>	<2>	<1>	<0>	<3>	<2>	<6>	<4>	<3>	<2>	<1>	<0>	<1>	<0>	<7>	<4>	<3>	<2>	<1>	<0>

其他功能命令设置定义 Other Function Command Settings Definition

SS<0>	Reset command set : 默认值为0, 1:同步PWM (PWM counter 于Trst 结束时被清除为0, 并于下一笔显示或是设置数据开始时, 重新启动) The default value is 0, 1: Synchronous PWM (PWM counter in Trst) At the end, it is cleared to 0 and restarted on the next display or when data is set to start
SS<2><1>	Reserved
SS<3>	显示数据同步设置: 0 显示数据等待Trst 结束时才同步更新生效; 1 异步数据, 更新(PWM 数据接收后立即生效、更新), (默认值:0) Display data synchronization settings: 0 Display data waiting for Trst to end before synchronization updates take effect; 1 Asynchronous data, update (PWM data takes effect immediately upon receipt, update), (default value: 0)
SS<5><4>	显示数据更新设置: 00:1.25khz ; 01:2.5khz; 10:10khz; 11:20khz(默认值11) Display data update setting: 00:1.25kHz; 01:2.5kHz; 10: 10kHz; 11: 20kHz(Default value 11)
SS<6>	回传模式选择 Return mode selection 0: 回传芯片的最大驱动电流能力(灯串串接数目) 0: Maximum driving current capability of the feedback chip (number of light series connections) 1: 回传灯串的固定编码(编号) 1: Fixed code (number) for returning light string (默认值为0) (Default value is 0)
SS<7>	保留(默认值为 0) Reserved (default value is 0)

3、睡眠模式 Sleep mode for power saving

SK6112支持睡眠/唤醒模式以达到节能目的。当接收到24位0的RGB数据、8位0x5A特殊数据和复位命令时，SK6112将进入睡眠模式。在睡眠模式下，内置振荡器和相关电路被禁用。在睡眠模式下，SK6112的静态电流约为5uA（典型值）。当检测到Din引脚上的输入上升沿时，休眠的SK6112从休眠模式唤醒。通常Din引脚上的正脉冲可以用作唤醒触发器。醒来后，SK6112中的所有睡眠电路在1ms内恢复正常工作模式。为了唤醒下一个级联的SK6112，Din引脚上接收到的正脉冲被传递到Dout引脚，该Dout引脚连接到下一个SK6112的Din引脚，并且继而唤醒下一个SK6112e。因此，所有级联的休眠SK6112都可以连续唤醒。由于休眠的SK6112需要1ms才能恢复到正常工作模式，因此建议MCU在发出唤醒脉冲后等待1ms才能发送显示数据和命令。在LED灯带中，可以将某些SK6112设置为活动，而其他SK6112则处于睡眠模式。例如，以下命令适用于两个领先的活跃SK6112和其他休眠SK6112。

进入睡眠的示例:

SK6112 supports sleep/wake-up modes for power-saving purpose. When receiving 24-bit 0's RGB data, 8-bit 0x5A special data, and a reset command, SK6112 will enter sleep mode. In sleep mode, the built-in oscillator and associated circuitry is disabled. The quiescent current of SK6112 is approximately 5uA (typ) in sleep mode.

A sleeping SK6112 wakes up from sleep mode when detecting an input rising edge on Din pin. Normally a positive pulse on Din pin can be used as a wake-up trigger. After waking up, all sleeping circuits in SK6112 return to normal working mode within 1ms. To wake-up the next cascaded SK6112, the received positive pulse on Din pin is passed to Dout pin, which connected to Din pin of the next SK6112, and in turn wakes up the next SK6112. Hence, all cascaded sleeping SK6112s can wake up successively.

Since it takes 1ms for a sleeping SK6112 returning to normal functioning mode, it is recommended for MCU to wait for 1ms to send display data and commands after issuing a wake-up pulse.

In an LED strip, it is possible to set certain SK6112s active, while the others in sleep mode. As an example, the following commands are for two leading active SK6112s and other sleeping SK6112.

Example of entering sleep:

RGB 24 ' h100FFF	RGB 24 ' h2345678FFF	RGB 24 ' h000000	RGB 24 ' h000000	PD8 ' h5A	+	Reset code >250 us
---------------------	----------------------------	---------------------	---------------------	--------	-----------	---	--------------------------

唤醒范例 Wake up example:

作为下面所示的睡眠/唤醒命令的示例，第一个SK6112保持活动，其余SK6112通过24位0和结束0x5A字节进入睡眠模式。稍后，一个正脉冲唤醒了所有正在睡眠的SK6112。

As an example of sleep/wake-up commands shown below, the first SK6112 is kept active and the remaining SK6112's enter sleep mode by 24-bit 0's and an ending 0x5A byte. Later on, a positive pulse wakes up all sleeping SK6112's.

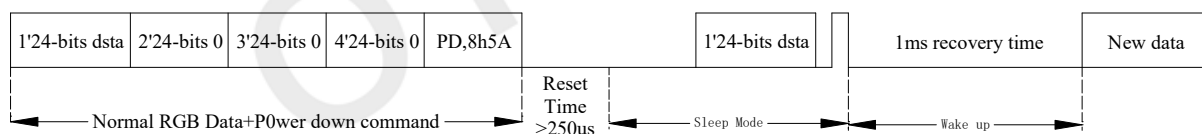

4、芯片多路并接、命令设置控制 :Control Commands for multiple strips connected parallely

SK6112支持通过并联连接控制多个条灯带（最多15个条）的场景。通过适当的命令，每个条灯带都可以被识别并分配一个唯一的条带动态ID（通过设置动态ID命令）。在命令完成后，MCU主机可以借助“Clean ID”、“Check ID”和“specify ID”命令分别控制并将显示数据发送到每个条带。

SK6112 supports the scenarios of controlling multiple strips with parallel connection (up to 15 strips). With appropriate commands, each of the strips can be identified and assigned a unique strip dynamic ID (by set dynamic ID command). After the commands is completed, MCU host can individually control and send the display data to each strip with the help of "Clean ID"、"Check ID"、"specify ID" commands.

命令格式 Command format to setup strip dynamic ID ::

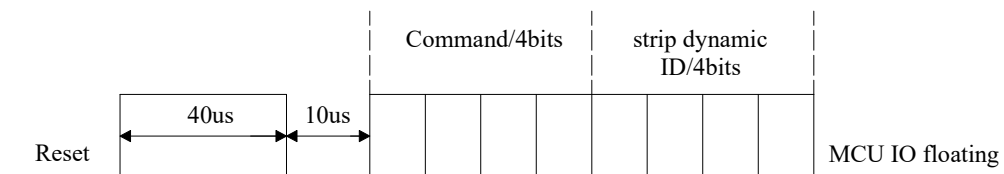

Command	Strip dynamic ID(4-bit)
4'b0001	Set_ID (1~15)
4'b0010	Clean_ID (1~15)
4'b0011	Check_ID (1~15)
4'b0100	Specify_ID(assign a specific strip to receive data)

动态ID 编码命令的设置方式 (The setting method of dynamic ID encoding command) /Set_ID (4'b0001):

在多路并接内置SK6112灯串应用情境下, 上电复位后, 所有灯串默认动态ID 号均为0。MCU 可以通过发出带有4'b0001 和4 位新动态ID 码 (4'b0001~4b'1111) 的设置命令, 对灯串进行编码, 更改灯串的动态ID。MCU 发出命令后, 并接下每条灯串的第一颗SK6112芯片开始执行编码程序。当领先的SK6112 芯片完成编码动作后, 该芯片会在Din 端口上产生一个正脉冲, 脉波宽度约77us (+/- 20%), 同时, 将此动态ID 码注册为该灯串之ID 编号。

其他灯串之第一颗SK6112芯片在生成脉冲前, 若在Din 端口感知已有正脉冲产生, 它将立即停止编码动作并等待MCU 产生新的编码设置命令。

MCU 重复向灯串发出设置命令、进行编码, 使并接的所有灯串均有唯一的动态ID 号码。MCU 发出编码命令后, 在约10us~60us 时间范围内会返回约77us 正脉冲。若在约60us 的时间内没有正脉冲回传, 意味所有灯串已完成编码程序。

为了避免MCU GPIO 的输出和SK6112的Din 端口的反馈回传脉冲之间的信号电平冲突, 建议在发出set ID 命令后, 在8us 时间内将MCU GPIO 属性更改为输入模式, 监控是否有灯串产77us 的正脉冲。

In the application scenario of multi way parallel connection with built-in SK6112 light string, after powering on and resetting, all light strings default to a dynamic ID number of 0. The MCU can encode the light string and change its dynamic ID by issuing a setting command with a new 4-digit dynamic ID code (4'b0001-4b'1111). After the MCU issues the command, it starts executing the encoding program by connecting the first SK6112 chip of each light string. After the leading SK6112 chip completes the encoding action, it will generate a positive pulse on the Din port, with a pulse width of about 77us (+/-20%), and register this dynamic ID code as the ID number of the light string.

If the first SK6112 chip of the other light strings detects a positive pulse before generating a pulse at the Din port, it will immediately stop encoding and wait for the MCU to generate a new encoding setting command.

The MCU repeatedly sends setting commands and codes to the light string, so that all parallel light strings have a unique dynamic ID number. After the MCU sends the encoding command, it will return a positive pulse of approximately 77us within a time range of about 10us~60us. If there is no positive pulse feedback within approximately 60us, it means that all light strings have completed the encoding program.

To avoid signal level conflicts between the output of MCU GPIO and the feedback return pulse of the DIN port of SK6112, it is recommended to change the MCU GPIO attribute to input mode within 8us after issuing the set ID command, and monitor whether there are 77us positive pulses produced by the light string.

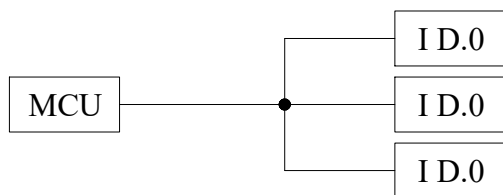

上电复位后, 灯串默认的动态ID 为0

After powering on and resetting, the default dynamic ID of the light string is 0

范例: 将某灯串的动态ID 设置为“ 5”。 Example: Set the dynamic ID of a certain light string to "5".

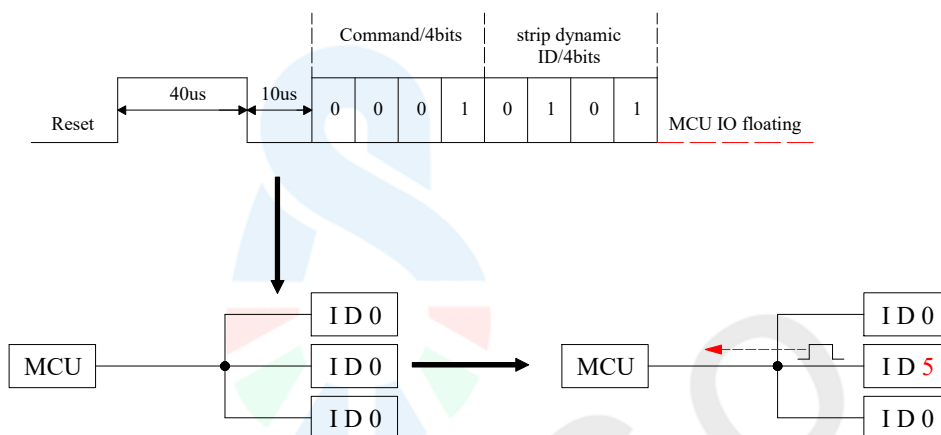

清除灯串动态ID 的设置方式 (Setting method for clearing dynamic ID of light string) /Set_ID (4'b0010):

MCU 可透过清除ID 的命令设置, 将某一条灯串的编码清除, 回复至默认值“ 0”。

MCU can clear the encoding of a certain light string and return it to the default value of "0" through the command to clear ID.

范例: 将动态ID=3 的灯串清除为“ 0”。 Example: Clear the dynamic ID=3 light string to "0".

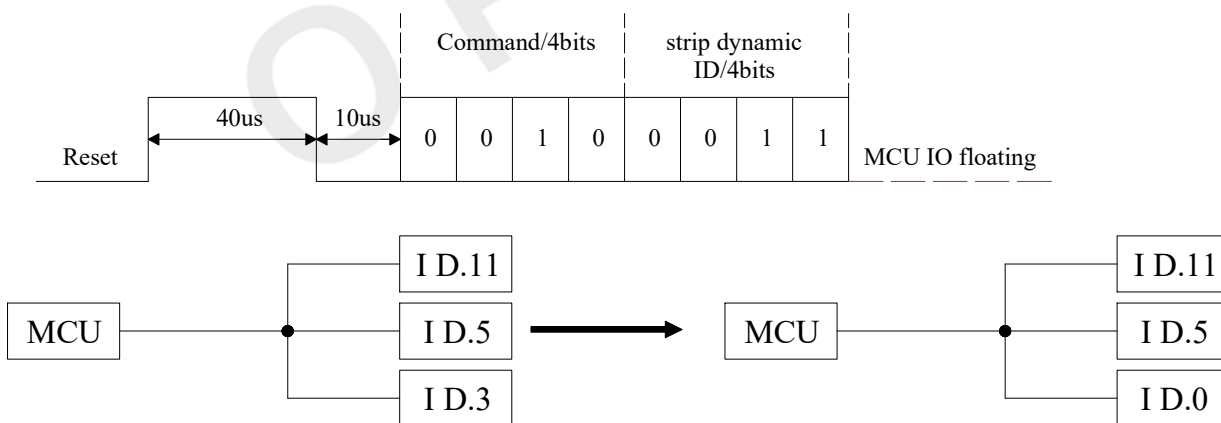

注:MCU 可以透过清除命令+ID="0"的设置方式, 一次清除所有灯串的动态ID。

Note: Host MCU can issue clean command + ID="0" to clean all existing dynamic strip IDs in a time.

确认灯串ID 的设置方式 Command to check dynamic strip ID /CHK_ID (4'b0011):

MCU可以使用check Strip ID命令来确认具有特定ID的条带是否已经存在。例如，当Strip 5接收到如下命令和ID数据时，其前导SK6112将通过Din端口返回一个宽度约为77us的正脉冲。（相关时序波形与SET_ID命令相似）；

MCU can use the check Strip ID command to confirm if a strip with a specific ID already exists. For example, while the Strip 5 receives the command and ID data as below, its leading SK6112 will return a positive pulse with about 77us width via Din port. (the related timing waveform is similar to the one of SET_ID command) ;

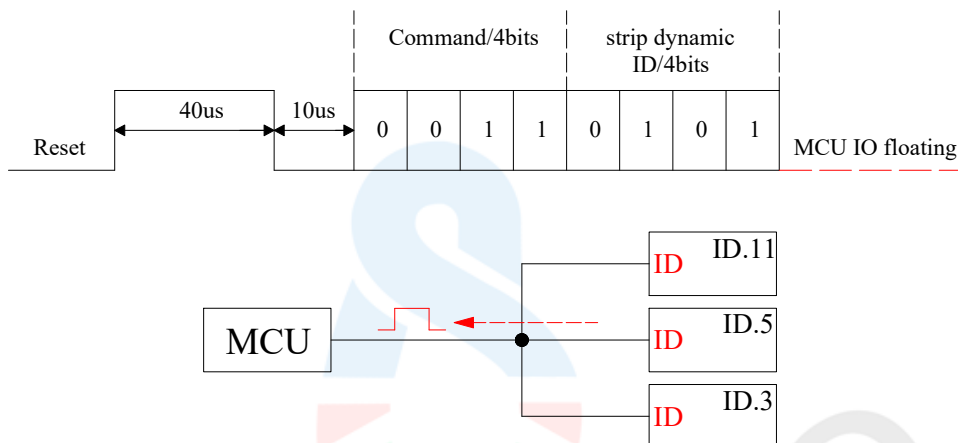

指定灯串执行命令的设置方式/Specify_ID (4'b0100) Command to specify a unique Strip to receive data /specify_ID (4'b0100):

MCU可以发出“指定ID命令”，强制特定条带接收RGB显示数据或执行特殊动作（如执行反馈模式命令或设置模式命令）。

另一方面，MCU也可以通过“指定命令+ID=“0”/4'b0000”发出广播命令，强制所有现有的动态ID条接收以下显示数据或一起执行设置模式命令。

如果MCU在发送RGB数据或执行反馈或设置模式命令之前没有执行“指定ID命令”来选择特定的条带，则ID=“0”的所有条带都将接收数据并执行操作。

MCU can issue “specify ID command” to force a specific strip to receive RGB display data or execute special actions (such as executing feedback mode command or setup mode command).

On the other hand, MCU also can issue broadcast command by “specify command +ID=“0”/4'b0000 “to force all existing dynamic ID strips to receive the following display data or execute setup mode command together.

If MCU does not execute “specify ID command” to select a specific strip before sending RGB data or executing feedback or setup mode command, all strips with ID=“0” will receive the data and execute actions.

SK6112 的合规使用 Compliant usage of SK6112:

MCU可以使用check Strip ID命令来确认具有特定ID的条带是否已经存在。例如，当Strip 5接收到如下命令和ID数据时，其前导SK6112将通过Din端口返回一个宽度约为77us的正脉冲。（相关时序波形与SET_ID命令相似）；

SK6112 strips may be used in a multi-strip application, SK6112 supports larger pulse width tolerance. That is 10~20us+10us+50us (note: +/-20% tolerances of the above timing);

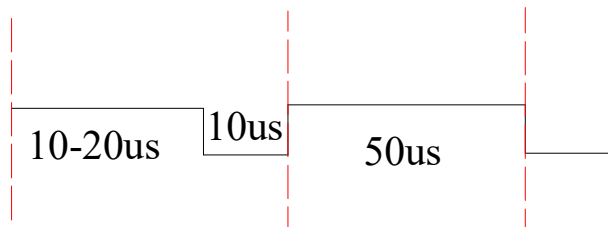

建议执行以下反馈模式命令: Recommendation to execute the feedback mode command as follows:

- 1、上电复位后，MCU先执行set ID命令，得到每条带SK6112的唯一ID;
 - 2、在完成ID分配过程后，MCU依次向目标条带发出指定命令，然后发出脉冲为12us+10us+50us的反馈命令（只有符合ID号的条带才会执行反馈动作）；
 - 3、完成所有SK6112条带的反馈模式动作后，MCU重新发出脉冲宽度为“20us+10us+50us”的反馈模式;
1. After the power-on reset, MCU execute set ID command first to obtain the unique ID for every strip with leading SK6112;
 2. After the ID assignment process is done, MCU sequentially issues the specify command to the target strip, and then issues the feedback command with pulse of 12us+10us+50us(only the strip that conforms to the ID number will perform the feedback action);
 3. After finishing the feedback mode actions for all SK6112 strips, then MCU re-issues the feedback mode with pulse width of “20us+10us+50us”;

回传固定ID Feedback the fixed strip ID:

SK6112还具有反馈固定带ID的功能和能力。

SK6112 also features the function and capability to feedback the fixed strip ID .

回传灯串固定的ID 序号编码 Command to feedback fixed strip ID :

- 1.首先执行“指定动态ID命令”，指定具体条带接受以下命令；
 - 2.发出反馈模式命令以获取信息，这条带中要连接的数字是多少；
 - 3.然后为条带中的每个芯片发出“高级设置模式”命令和数据，其中SS<6>位=“1”；
 - 4.执行“回传模式命令”；
 - 5.如果LED条上级联了“M”个SK6112，则前导SK6112的DI端口将生成并反馈“M”脉冲。每个80us周期中的10us高脉冲表示为“0”，否则，80us内的40us高脉冲则表示为“1”。注意：对于每个SK6112芯片，数据“0”或“1”是随机的。
 - 6.当MCU在160us内没有接收到任何高脉冲时，MCU和SK6112应退出反馈模式，返回正常功能模式；
 - 7.MCU按顺序收集并组合“0”或“1”的反馈数据串，即来自条带上每个SK6112的数据串为一个序列号，该序列号代表该条带的固定条带ID；
 - 8.重复发出第1项至第7项的命令，得到每条条带的固定条带ID号；
1. Execute “specify dynamic ID command” first and specify the specific strip to accept the following command;
 2. Issue feedback mode command to get the information ,what’s the numbers to be connected in this strip;
 3. Then issue “high level setup mode” command and data with SS<6> bit=“1” for each chip in the strip;
 4. Execute “feedback mode command”;
 5. The DI port of leading SK6112 will generate and feedback “M” pulses if there are “M” numbers of SK6112 cascaded on the LED strip. 10us high pulse in each 80us period is denoted as “0”, otherwise, 40us high pulse within 80us is denoted as “1”. Note : data “0” or “1” is random for each SK6112 chip;
 6. While MCU does not receive any high pulse within 160us, MCU and SK6112 should get out of feedback mode and go back to normal function mode;
 7. MCU collects and combines the feedback data string of “0” or “1” in order ,that is coming from each SK6112 on the strip to be a serial number, the serial number is to stand for the fixed strip ID for this strip;
 8. Repeatedly issue the commands from item 1 to 7 to get the fixed strip ID number of strips for each strip;

12. 光电特性 Photoelectric characteristic:

焊盘温度与光通量输出的相对关系
 The relative relationship between pad temperature and luminous flux output

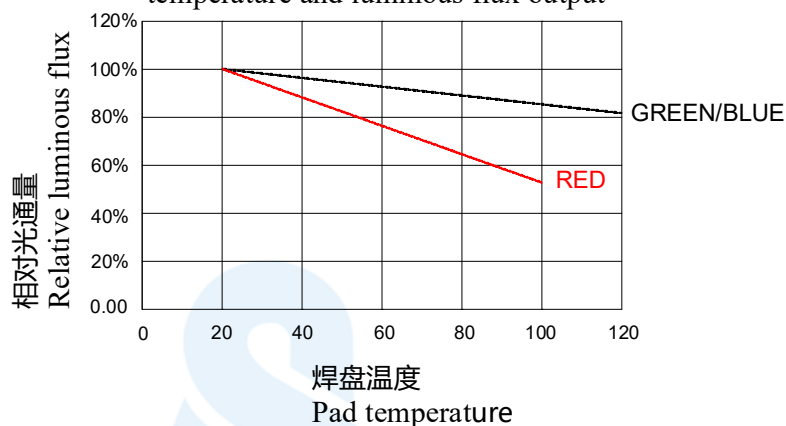

波长特性
 Wavelength characteristics

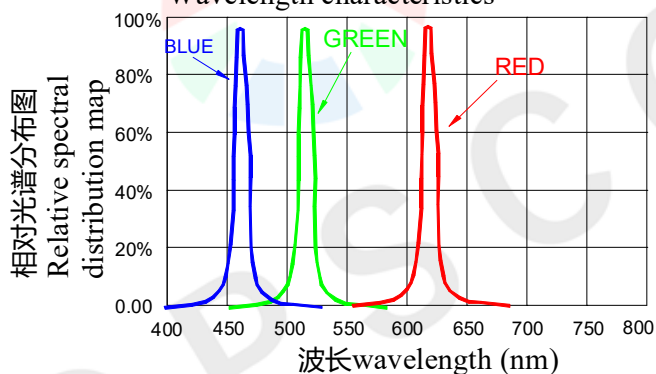

典型的辐射方向图 120°
 Typical radiation pattern 120°

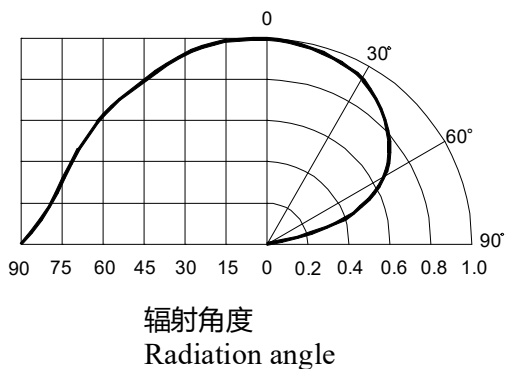

13. 包装标准 Packaging standards:

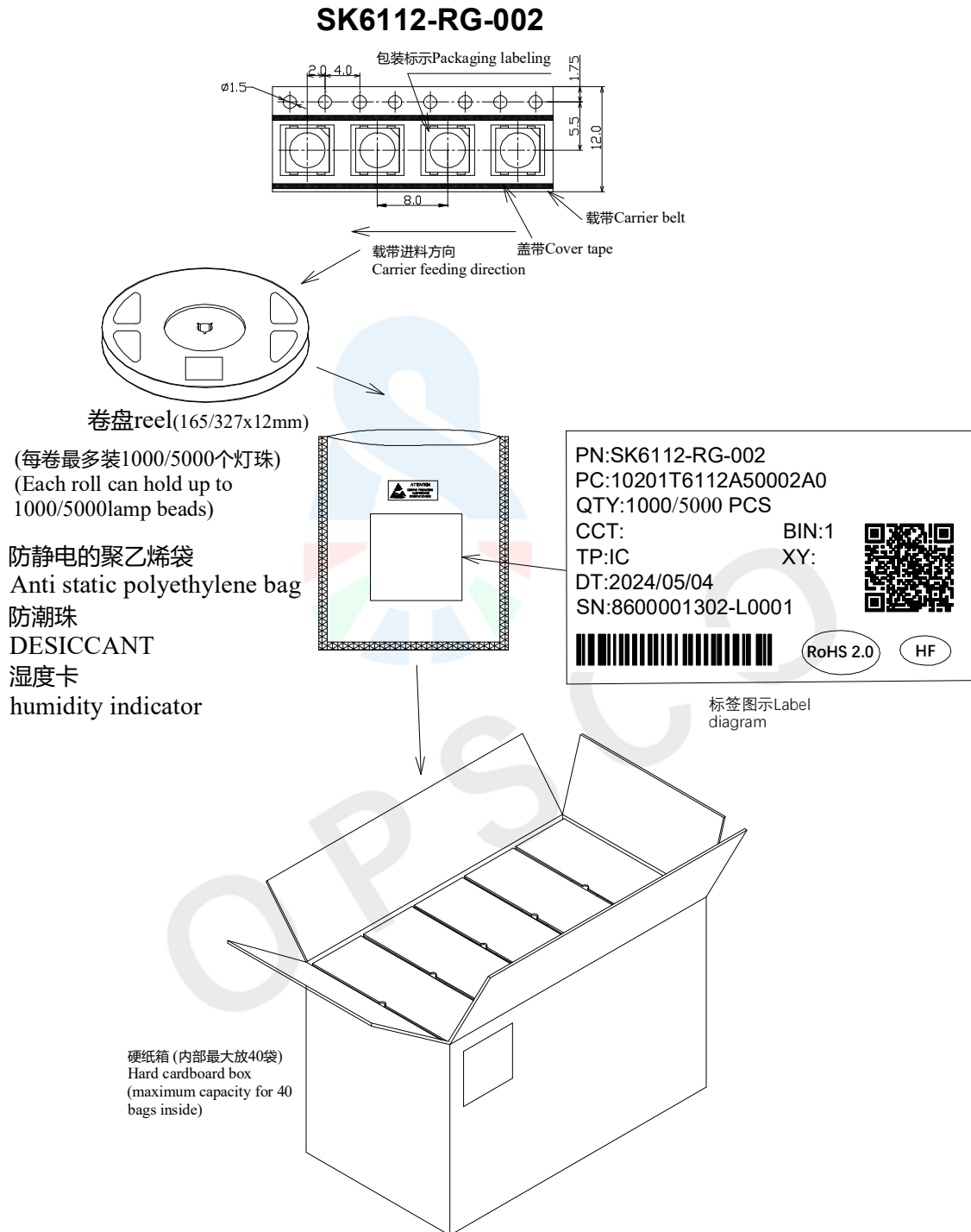

表面贴装LED采用卷盘包装, LED在用普通或防静电袋包装后再装在纸箱中. 纸箱用于保护运输途中LED不受机械冲击, 纸箱不防水, 因此请注意防潮防水。

Surface mounted LEDs are packaged in rolls, and the LEDs are packaged in regular or anti-static bags before being packed in cardboard boxes. The cardboard box is used to protect the LED from mechanical impact during transportation. The cardboard box is not waterproof, so please pay attention to moisture-proof and waterproof.

14. 可靠性测试 Reliability testing:

序号 Serial Number	实验项目 Pilot projects	实验条件 experimental condition	参考标准 Reference standards	判断 determine
1	冷热冲击 Thermal Shock	100 ± 5°C ~ -40°C ± 5°C 15min~15min 100cycles	MIL-STD-202G	0/22
2	高温储藏 High temperature storage	Ta= +100°C 1000hrs	JEITA ED-4701 200 201	0/22
3	低温储藏 low temperature storage	Ta= -40°C 1000hrs	JEITA ED-4701 200 202	0/22
4	高温高湿储藏 High temperature and high humidity storage	Ta=60°C RH=90% 1000hrs	JEITA ED-4701 100 103	0/22
5	温度循环 Temperature cycling	-40°C~25°C~100°C~25°C 30min~5min~30min~5min 100 cycles	JEITA ED-4701 100 105	0/22
6	耐焊接热 Resistance to Soldering Heat	Tsld = 260°C, 10sec. 2 times	JEITA ED-4701 300 301	0/22
7	常温寿命测试 Normal temperature life test	25°C, IF: Typical current , 1000hrs	JESD22-A 108D	0/22

失效判定标准 Failure criteria:

项目 project	符号 symbol	测试条件 Test conditions	判断标准 Judgment criteria	
			最小值 Minimum value	最大值 Maximum value
发光强度 intensity	IV	DC=5V,规格典型电流 DC=5V, typical current specification	初始数据X0.7 Initial data X0.7	---
耐焊接热 Resistance to Soldering Heat	---	DC=5V,规格典型电流 DC=5V, typical current specification	无死灯或明显损坏 No dead lights or obvious damage	

