

反射式光电开关

特点 (Characteristic) :

* 可靠性高、辐射强度高、低电压驱动

High reliability 、High radiant intensity 、Low forward voltage

* 感应速度快、感光度强

Fast response time 、High photo sensitivity

* 截止感应波长940nm

Cut-off visible wavelength $\lambda_p=940\text{nm}$

* 无铅材料、RoHS认证

Pb.Free 、RoHS compliant version

* 湿气敏感性等级 (MSL) :3级

Moisture sensitivity level (MSL) : 3 levels



模型图仅供参考

应用领域 (Product application) :

* 鼠标

Mouse

* 打印机复印机

Printer copier

* 开关扫描仪软盘驱动器

Switch scanner floppy drive

* 非接触式开关直接板

Non contact switch direct board

* 感应洁具

Induction sanitary ware

* 感应水龙头

Sensor faucet



目录

Catalogue

电性参数 Electrical Characteristics.....	3
典型特性曲线 Typical Characteristic Curves.....	5
可靠性试验项目和条件 Reliability Test Items and Conditions	8
外形尺寸 Outline Dimensions.....	9
包装 Packaging.....	10
焊接指导 Guideline for Soldering.....	12
使用注意事项 Precautions.....	14

电性参数

Electrical Characteristics

极限参数 (温度=25°C): Absolute Maximum Ratings (Temperature=25°C):

测试项目 Parameter		符号 Symbol	数值 Ratings	单位 Unit
输入端发射极 Input Emitter	功率 Power Dissipation*1	PD	50	mW
	正向输入电流 Continuous Forward Current	IF	20	mA
	脉冲正向电流 Peak Forward Current*2	IFP	80	A
	反向电压 Reverse Voltage	VR	5	V
输出端接收极 Output Detector	功率 Power Dissipation*1	PD	100	mW
	集电极-发射极电压 collector-emitter voltage	Vceo	30	V
	发射极-集电极电压 emitter-collector voltage	Veco	5	V
	抗静电能力 Antistatic capability	ESD	2000	V
工作温度 Operating Temperature		Topr	-20~+85	°C
储存温度 Storage Temperature		Tstg	-40~+85	°C
焊接温度 Lead Soldering Temperature*3		Tsol	240 < 8S	°C

- 1、在 25 摄氏度的环境中测试 below 25 Free Air Temperature
- 2、脉宽少于等于 100us , 占空比 1% Pulse width \leq 100 μ s,Duty cycle= 1%
- 3、离胶体 2mm 以上焊接 5s 内 2mm form body for 5 seconds

光电参数 (温度=25°C):

Electro-Optical Charasteristics (Temperature=25°C):

参数 Parameter		符号 Symbol	测试条件 Test conditions	最小 Min	平均 Typ	最大 Max	单位 Unit
输入端 Input	正向电压 Forward Voltage	VF	IF=20mA	--	1.2	1.6	V
	峰值波长 Perk Wavelength	λP	IF=20mA	--	940	--	nm
	反向电流 Reverse Current	IR	VR=5V	--	--	10	μA
输出端 Output	集电极-发射极电压 collector-emitter voltage	Vceo	IC =0.1mA, IF =0mA	30	--	--	V
	发射极-集电极电压 emitter-collector voltage	Veco	IE =10uA, IF =0mA	5	--	--	V
	集电极-发射极的工作电压 C-E Saturation Voltage	VCE(sat)	IC=2mA Ee= 1mW/cm ²	--	--	0.4	V
	光电流 Collector Current	IC(ON)(B) IC(ON)(C)	IF=20mA VCE=5V	0.35	--	0.65	mA
				0.5	--	0.9	
暗电流 Dark Current	ICEO	Ee=0mW/cm ² VCE=20V	--	--	100	nA	
转换特性 Transfer Characteristics	上升时间 Rise Time	Tr	VCE=5V IC=20mA RL= 1000 Ω	--	15	--	μS
	下降时间 Fall Time	Tf		--	15	--	

备注(Note):

- 1、在 25 摄氏度的环境中测试 below 25 Free Air Temperature
- 2、脉宽少于等于 100us , 占空比 1% Pulse width \leq 100 μs , Duty cycle= 1%
- 3、离胶体 2mm 以上焊接 5s 内 2mm form body for 5 seconds

电压分档:

Voltage grading:

代码 Code	最小值 Min	最大值 Max	单位 Unit	测试条件 Test conditions
R2-4	1.2	1.6	V	IF=20mA

光电流分档:

Collector Current grading:

代码 Code	最小值 Min	最大值 Max	单位 Unit	测试条件 Test conditions
IC10-18	0.5	0.9	mA	IF=20mA VCE=5V

典型特性曲线

Typical Characteristics Curves

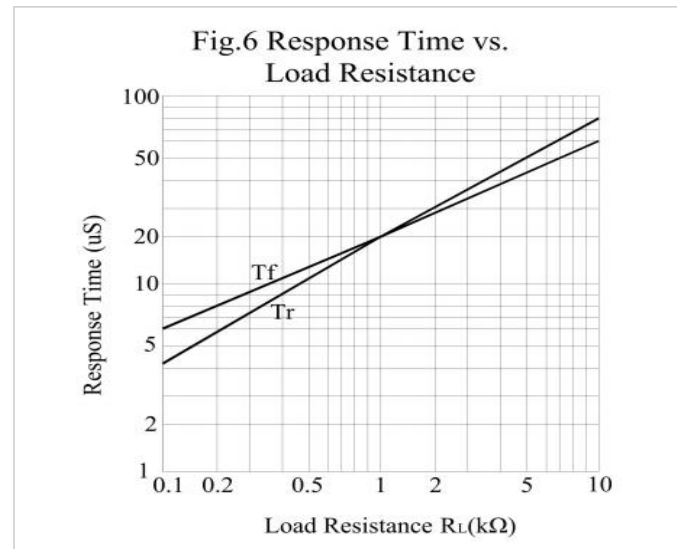
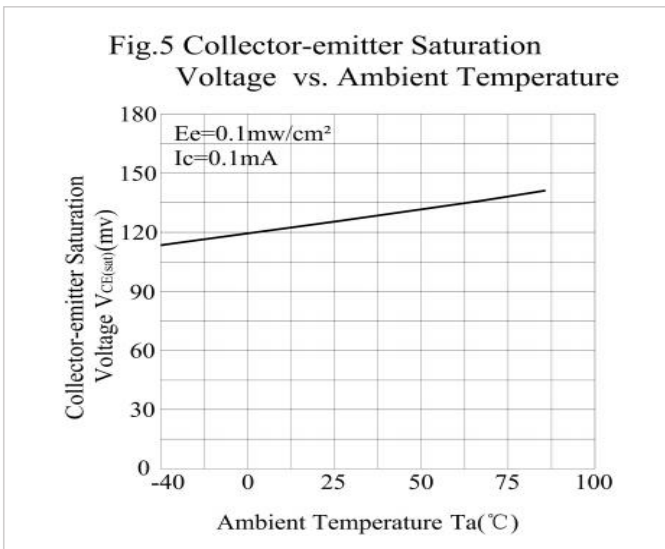
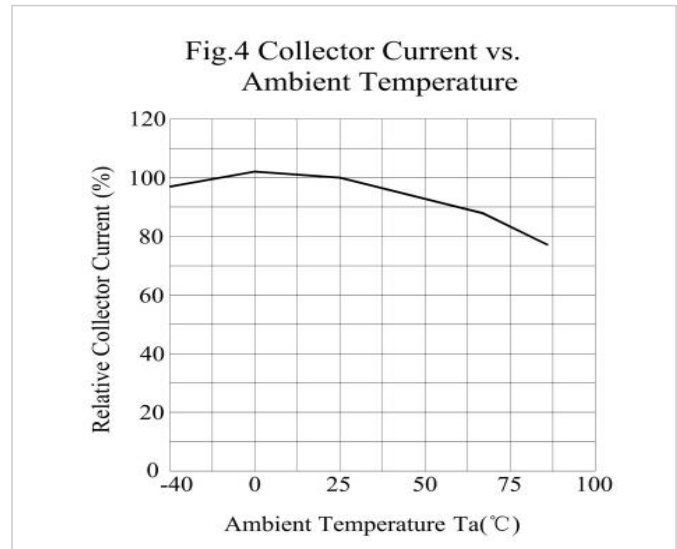
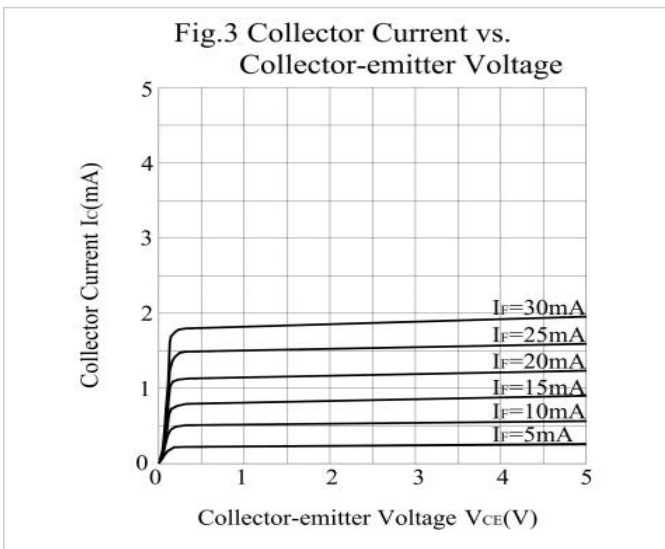
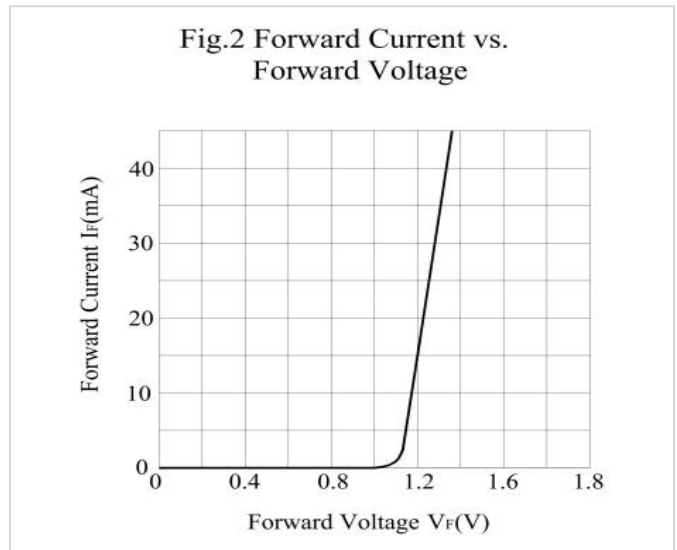
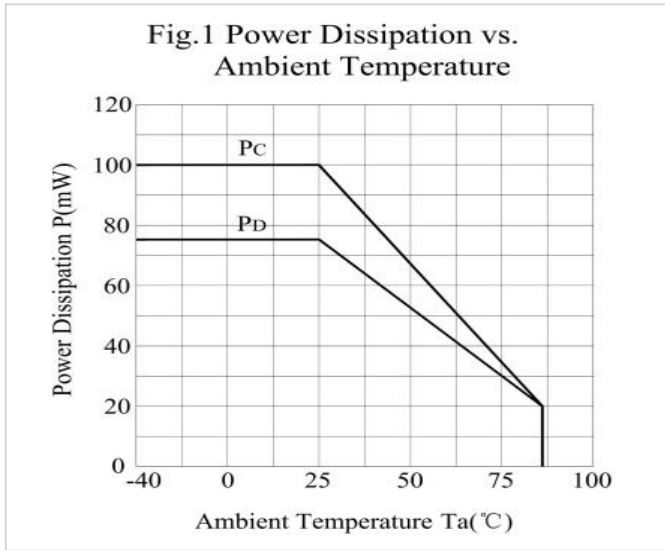

典型特性曲线

Typical Characteristics Curves

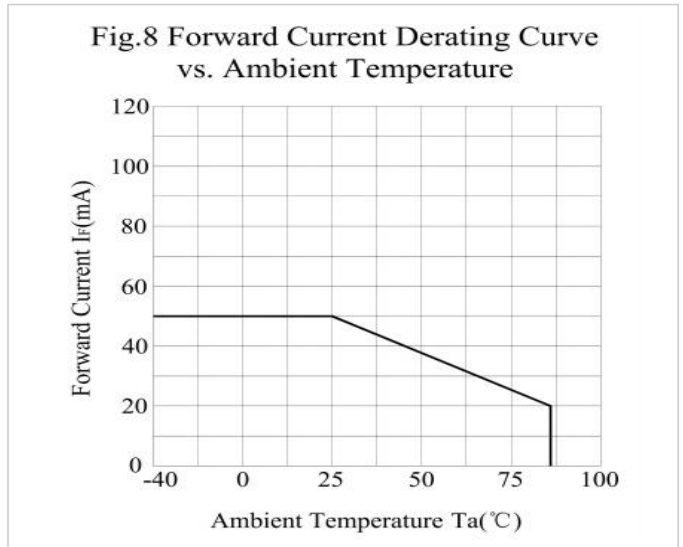
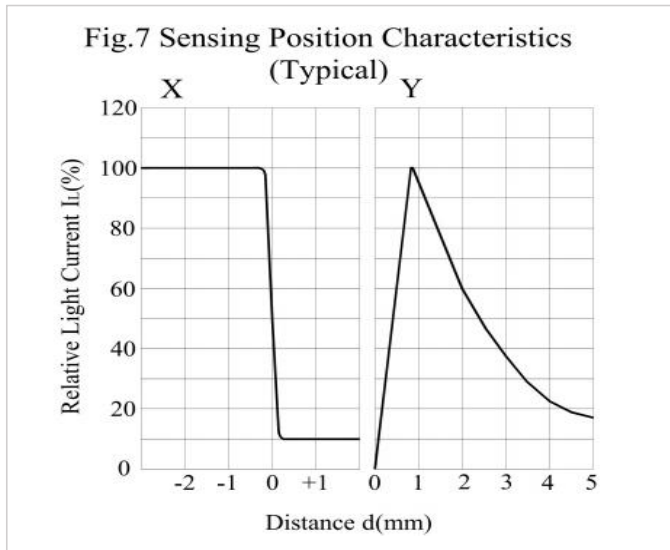

工作原理 operational principle:

工作原理:

用IO口控制传感器的红外发光部份工作时另一个IO口同时测量传感器的VOUT脚位上是否有高电平? 接收到反射信号后VOUT脚输出对应的线性电压, 信号越强电压越高。应用电测80%输出耳检测距离>2mm。(例如采用250us工作50ms休息(平均电流在30uA)。待机电流180nA)

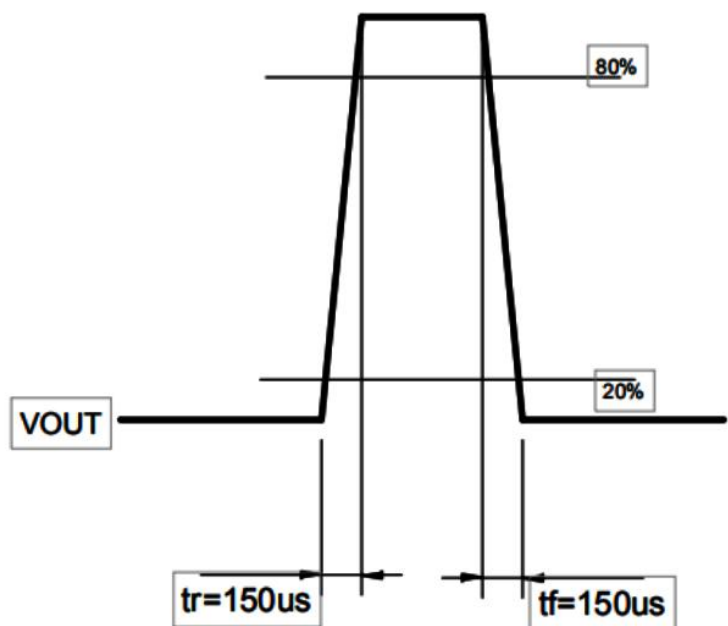
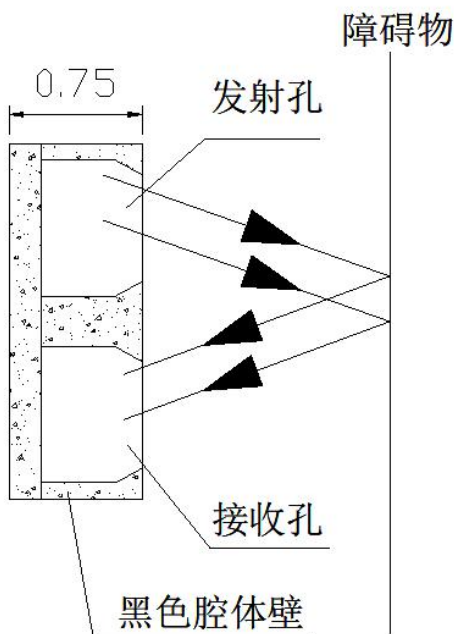

可靠性试验项目和条件

Reliability Test Items and Conditions

测试项目 Test Item	测试条件 Test Conditions	测试小时/次数 Test Hours/Times	单元次数/ 测试Units Failed/Test	接收/拒收 Ac/Re	标准 Criteria	
					IV@10mA	VF@10mA
回流焊 Reflow Soldering	260°C \leq 10S; 260°C (Max.), within 10seconds. (Max.)	3次 3 times	0/20	0/1	< \pm 10%	< \pm 10%
温度循环 Temperature cycle	(-40°C 30min \uparrow \downarrow 25°C (5min) 100°C 30min)	10个循环 10 cycles	0/20	0/1		
热冲击 Thermal Shock	(-40°C 20min \uparrow \downarrow 5sec 100°C 20min)	10个循环 10 cycles	0/20	0/1		
使用寿命 Operation Life	IF=20mA Vce=5V Ta=25 °C	1000小时	0/20	0/1	>70%	<100%
高温高湿贮存 High Temperature High Humidity Storage	温度100°C 湿度90-95% Ta=100°C RH=90-95%	240小时 240 hours	0/20	0/1		
高温存储 High Temperature Storage	温度100°C Ta=100°C	1000小时 1000 hours	0/20	0/1		
低温存储 Low Temperature Storage	温度40°C Ta=-40°C	1000小时 1000 hours	0/20	0/1		

注意:

- 1、单项测试应在2小时内完成。
- 2、测试的led已经恢复到测试前的正常环境条件。

Notes:

- 1、Measurement shall be taken within 2 hours.
- 2、The tested LED have been returned to normal ambient conditions before testing.

外形尺寸

Outline Dimension

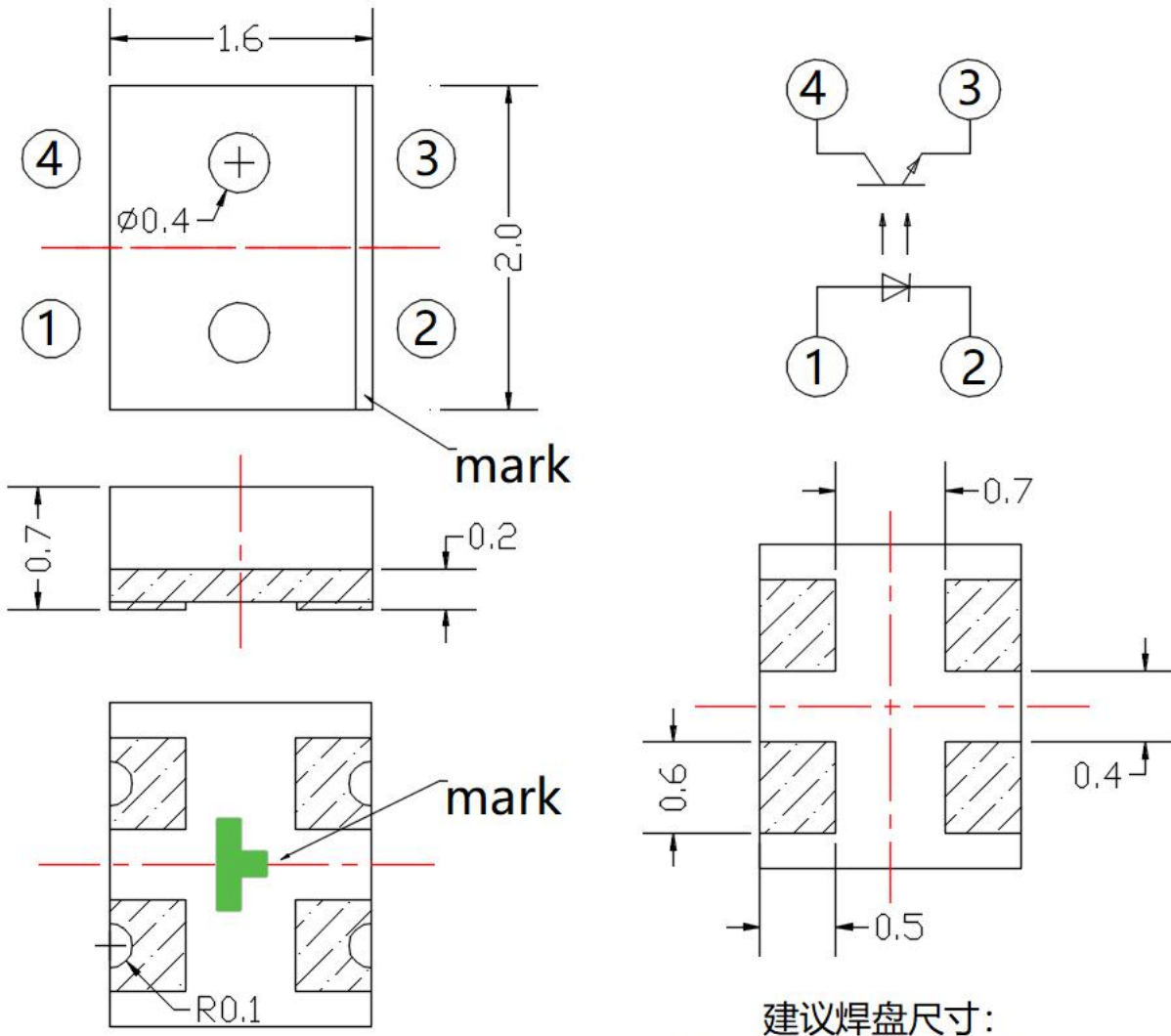

建议焊盘尺寸:
Recommended Soldering Pattern

备注:

1.单位: 毫米 (mm)

Remarks: 1 Unit: mm

2.公差: 无特别标注则为±0.3mm

包装(1)

Packaging(1)

●Dimensions for Reel (Unit: mm)

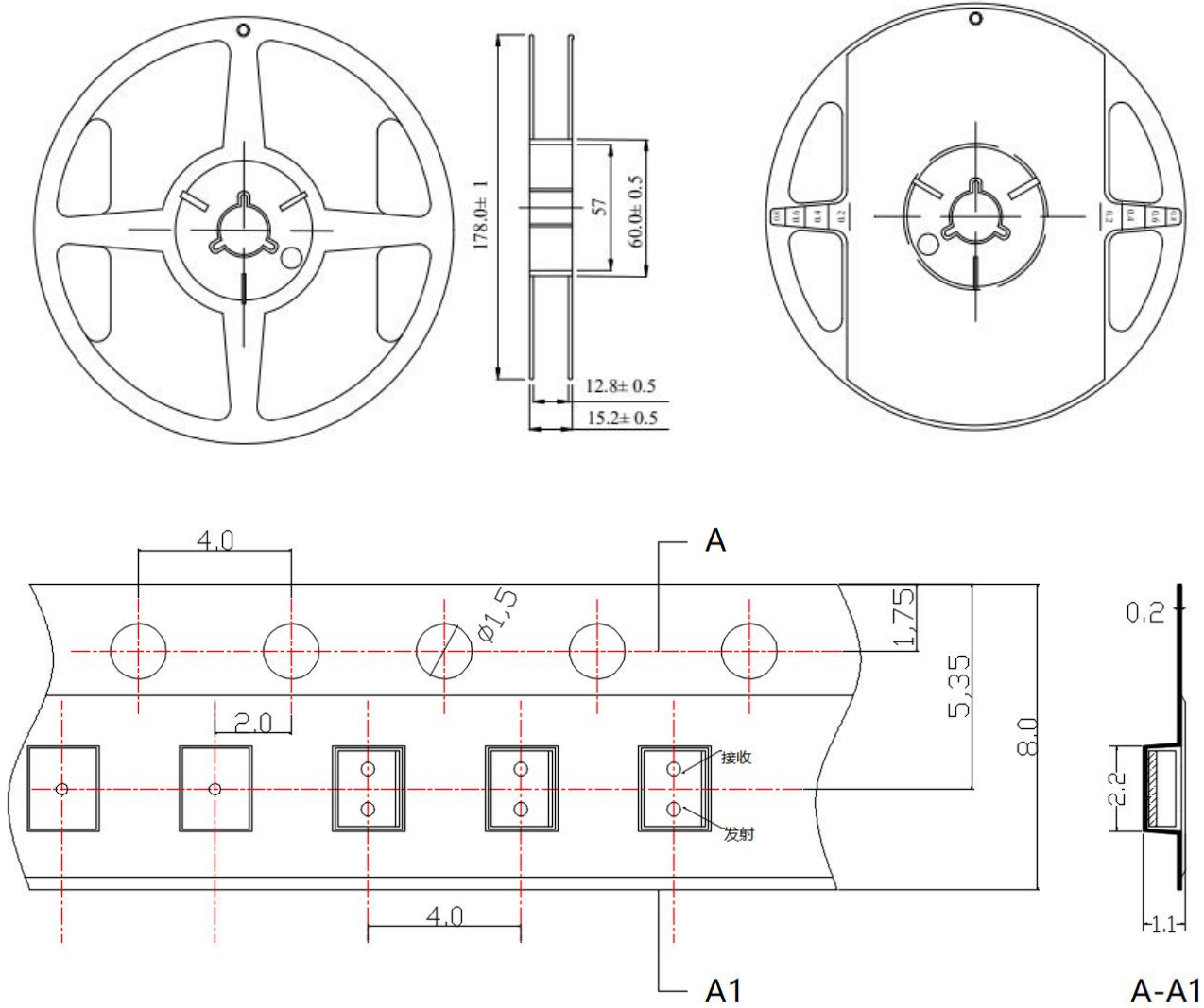

Notes:

- 1、 All dimensions are in mm, tolerance is ± 0.1 mm unless otherwise noted.
- 2、 Specifications are subject to change without notice.
- 3、 Loaded quantity: 1000 pcs/reel.

包装(2)

Packaging(2)

◇ 防潮抗静电包装 Moisture Proof and Anti-Electrostatic Foil Bag

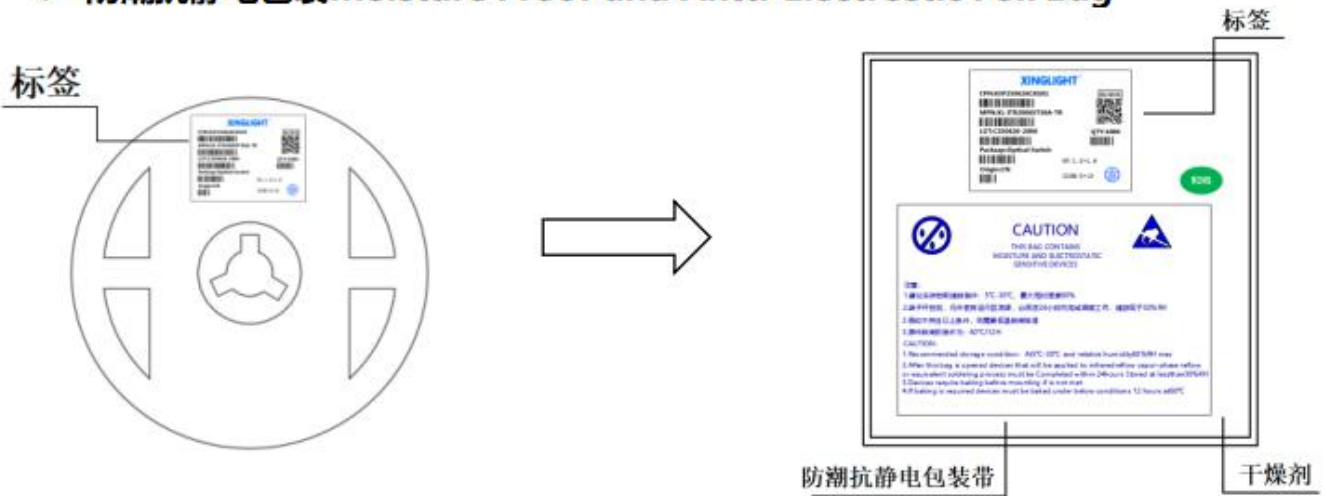

◇ 外包装箱 Cardboard Box

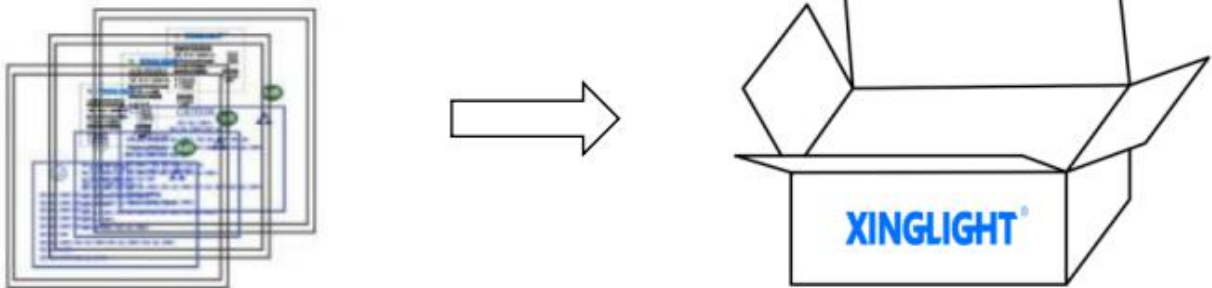

◇ 标签说明 Label Expantion

CPN: 批号/档位	LOT: 日期
MPN: 型号	VF: 电压
ORIGIN: 产地	IC: 光电流
PACKAQE: 封装	QTY: 数量



焊接指导

Guideline for Soldering

推荐焊接温度曲线 The wave peak welding curve is recommended :

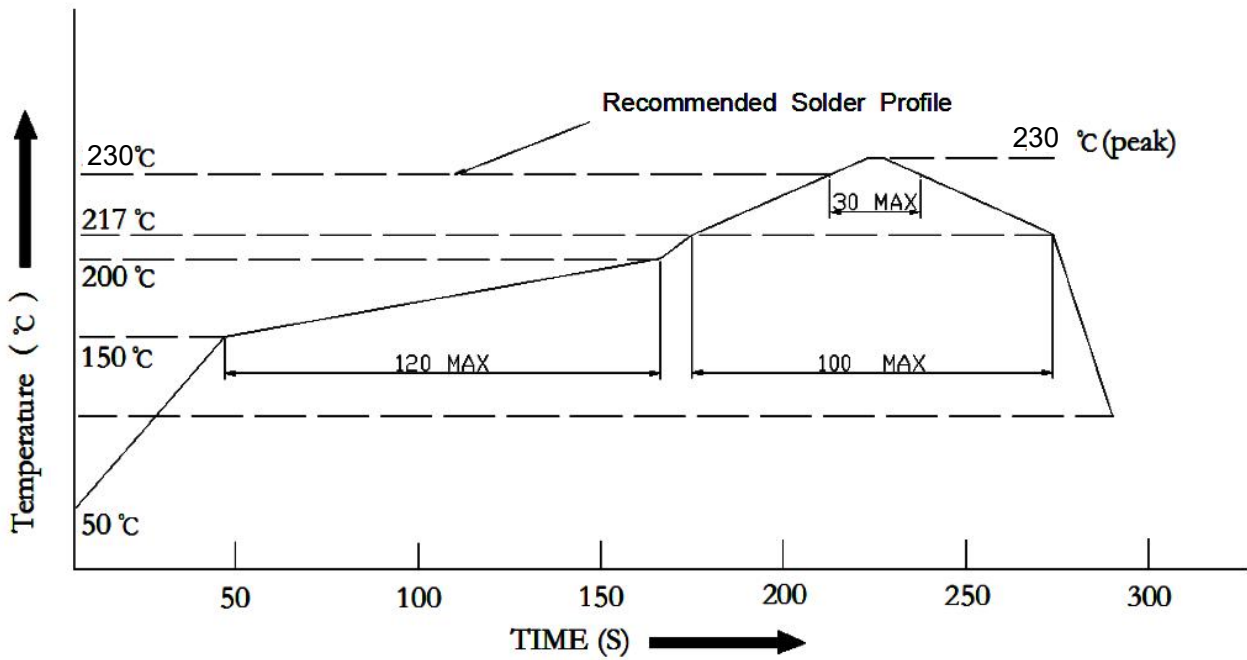

注意: Note

1、铅焊料温度剖面

Lead solder temperature profile

2、波峰焊不应做一次以上

Peak welding shall not be done more than once

3、焊接时，不要在加热过程中对 LED 施加压力

When soldering, do not put stress on the LED during heating

4、焊接后，不要使电路板翘曲

After soldering, do not warp the circuit board

烙铁条件 Soldering Iron

每个端子都要去烙铁尖端温度低于 350°C为 3 秒内一次少于烙铁容量 25W 。 离开两秒钟然后更多的间隔，并做焊接每个终端。手工焊料通常在开始的时候容易损坏产品。

Each terminal is to go to the tip of soldering iron temperature less than 350°C for 3 seconds within once in less than the soldering iron capacity 25W. Leave two seconds and more intervals, and do soldering of each terminal. Be careful because the damage of the product is often started at the time of the hand solder.

*手工补数 Repairing

修理不应在 LED 焊接后进行。当修理是不可避免的是，应该使用双头烙铁 (如下图所示)。应该是事先确认 LED 的特性是否会或不会损坏通过修理。

Repair should not be done after the LEDs have been soldered. When repairing is unavoidable, a double-head soldering iron should be used (as below figure). It should be confirmed beforehand whether the characteristics of the LEDs will or will not be damaged by repairing.

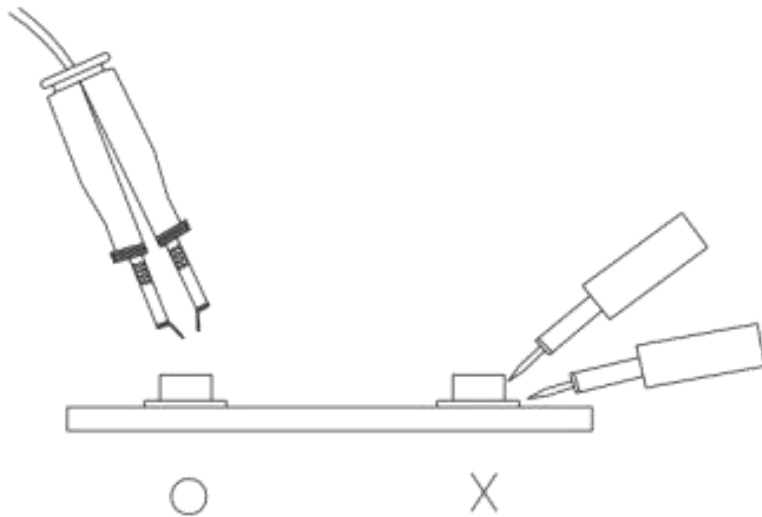

使用注意事项

Precautions

2016由红外发射二极管和 NPN 硅光晶体管组成，它们并排封装在黑色热塑性外壳中的汇聚光轴上。光电晶体管只接收来自IR的辐射。这是正常情况。但当物体在中间时，光电晶体管不能接收辐射。有关更多组件信息，请参阅IR和PT。

2016 It is composed of infrared emission diode and NPN silicon photo transistor, which are packaged side by side in black On the converging optical axis in the thermoplastic shell. Photo transistor only receives radiation from IR. This is normal Condition. But when the object is in the middle, the photo transistor cannot receive radiation. For more component information, please Refer to IR and PT.

* 注意: Note

*过流保护 Over-current-proof

1、客户必须应用电阻进行保护，否则会造成轻微电压偏移大电流变化（烧毁将发生）。

Customer must apply resistors for protection, otherwise slight voltage shift will cause big current change (Burn out will happen).

-储存 Storage

1、产品准备使用前不要打开防潮袋。

Do not open moisture proof bag before the products are ready to use.

2、在打开包装之前，二极管应保持在 10°C~30°C和 90%RH 或以下。

Before opening the package, the LED should be kept at 10°C~30°C and 90%RH or less.

3、二极管建议在一年内使用。

The LED suggested be used within one year.

4、打开包装后，设备必须存储在 10°C~30°C 和 60%RH，并在 168 小时内使用（地板寿命）。如果未使用的二极管仍然存在，它应储存在防潮包装中。

After opening the package, the devices must be stored at 10°C~30°C and 60%RH, and used within 168 hours (floor life). If unused LED remain, it should be stored in moisture proof packages.

5、如果吸湿材料（干燥剂材料）已褪色或未打开的袋子已超过保质期或设备（袋外）已超过地板寿命，烘焙处理。

If the moisture absorbent material (desiccant material) has faded or unopened bag has exceeded the shelf life or devices (out of bag) have exceeded the floor life, baking treatment is required.

6、如果需要烘焙，请参阅 IPC/JEDECJ-STD-033 进行烘焙程序或建议以下条件：在 60°C±5°C 和 5%RH<96 小时（筛/管/套单位）

If baking is required, refer to IPC/JEDEC J-STD-033 for bake procedure or recommend the following conditions: 96 hours at 60°C ± 5°C and < 5 % RH (reeled/tubed/loose units)