

## MCMB-0624 Series

### High Current Molded Power Inductors

#### FEATURES

- Powder iron core material
- Magnetically shielded, low EMI
- High current carrying capacity, Low core losses
- Frequency range up to 3MHz
- Operate temperature range ....  $-40^{\circ}\text{C} \sim +125^{\circ}\text{C}$  (Including self temp. rise)
- RoHS compliant

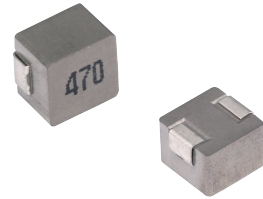

#### APPLICATIONS

- Voltage Regulator Module (VRM)
- Multi-phase regulators
- Point-of-load modules
- Smart phone POL modules
- SSD modules
- Notebook regulators
- Battery power systems
- Graphics cards
- Data networking and storage systems

#### Explanation of Part Number

MCMB -0624 -1R0 M T

1 2 3 4 5

- ◆ 1:Product Series:Metal Alloy Molding Power Inductor
- ◆ 2:Dimensions:
- ◆ 3: Initial inductance value: 1R0 = 1.0uH
- ◆ 4:Tolerance of Inductance:M: $\pm 20\%$
- ◆ 5.Packing:Tape Carrier Package

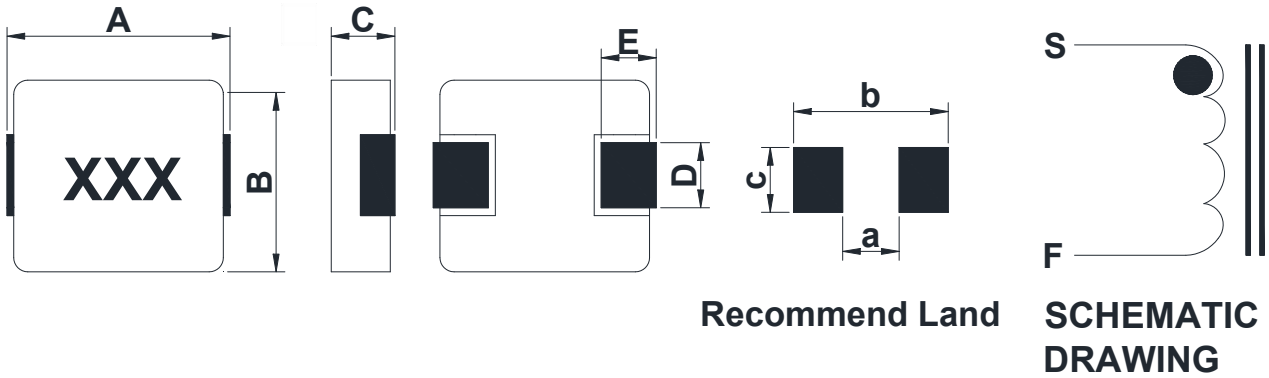
**Dimensions: [mm]**

**Recommend Land**
**SCHEMATIC  
DRAWING**

series	A	B	C	D	E	a (typ)	b (typ)	c (typ)
MCMB-0624	7.10±0.40	6.60±0.40	2.40MAX	3.00±0.50	1.60±0.50	3.70	8.40	3.50

**Electrical Properties:**

Part No.	Inductance	DC Resistance	Saturation Current	Heating Rating Current
	L0 (μH)±20 %	DCR (mΩ)	Isat (A)	Irms (A)
	100 kHz, 1V	MAX(TYP)	TYP.	TYP.
MCMB-0624-R10MT	0.10	1.35(1.20)	37.0	27.0
MCMB-0624-R15MT	0.15	2.30(1.63)	35.0	25.0
MCMB-0624-R22MT	0.22	3.00(2.60)	34.0	21.0
MCMB-0624-R33MT	0.33	4.10(3.50)	24.5	18.0
MCMB-0624-R47MT	0.47	5.10(4.80)	22.0	15.0
MCMB-0624-R56MT	0.56	6.50(5.50)	17.0	13.0
MCMB-0624-R68MT	0.68	7.00(5.80)	16.0	12.0
MCMB-0624-1R0MT	1.00	13.5(12.6)	16.0	9.00
MCMB-0624-1R5MT	1.50	20.0(17.0)	13.5	9.00
MCMB-0624-2R2MT	2.20	28.0(22.5)	11.0	7.00
MCMB-0624-3R3MT	3.30	39.0(35.0)	8.50	5.50
MCMB-0624-4R7MT	4.70	50.0(42.5)	7.50	5.00
MCMB-0624-6R8MT	6.80	70.0(62.0)	5.50	4.00
MCMB-0624-100MT	10.0	101(90.5)	4.00	3.10
MCMB-0624-150MT	15.0	160(135)	3.30	2.50
MCMB-0624-220MT	22.0	230(200)	2.50	2.00

**Notes**

1. All test data is referenced to 25 °C ambient
2.  $I_{rms}(A)$ :DC current (A) that will cause an approximate  $\Delta T$  of 40 °C(reference ambient temperature is 25°C)
3.  $I_{sat}(A)$ :DC current (A) that will cause L0 to drop approximately 30 %
4. The part temperature (ambient + temp rise) should not exceed 125 °C under worst case operating conditions. Circuit design, component placement, PWB trace size and thickness, airflow and other cooling provisions all affect the part temperature. Part temperature should be verified in the end application.
5. Absolute maximum voltage 30V

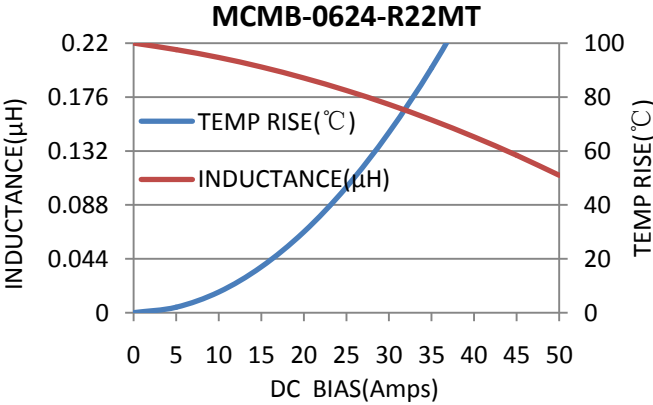
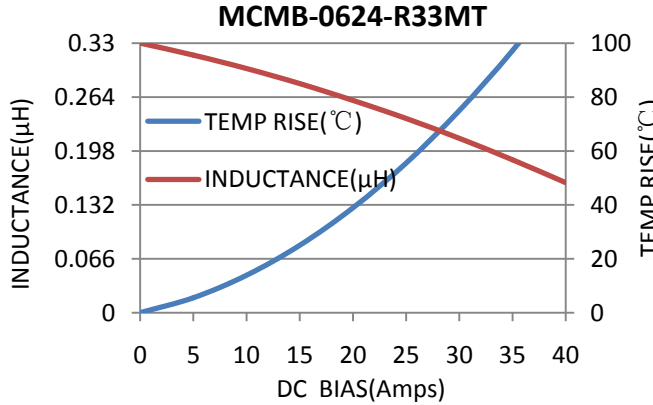
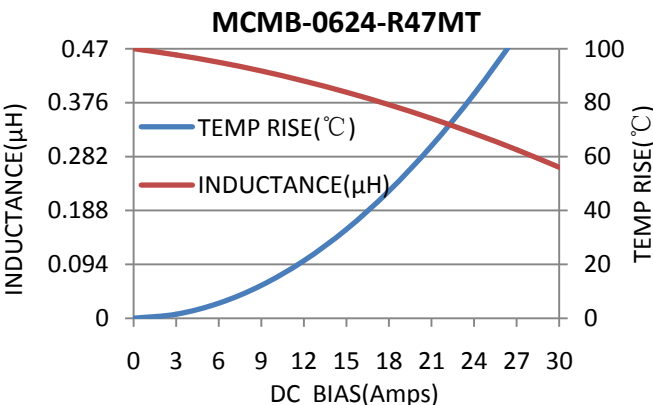
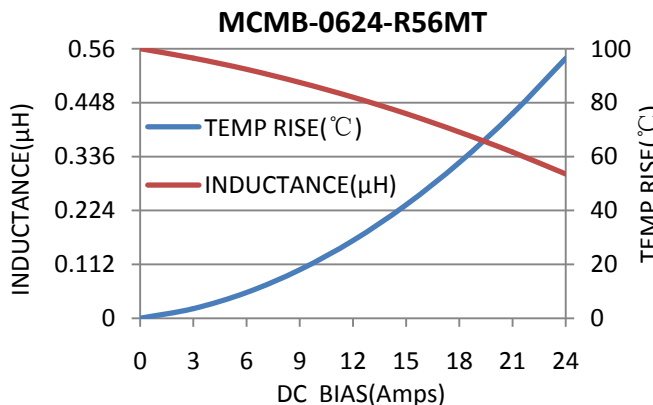
Performance Graphs	
Test Instruments	Test Condition
Wayne kerr 3260B/G LCR Meter Wayne kerr 3265B Bias Current Source	Temperature: 26 ± 3°C Humidity: < 70% RH Frequency: 100 KHz, 1.0V
<p style="text-align: center;"><b>MCMB-0624-R22MT</b></p> 	<p style="text-align: center;"><b>MCMB-0624-R33MT</b></p> 
<p style="text-align: center;"><b>MCMB-0624-R47MT</b></p> 	<p style="text-align: center;"><b>MCMB-0624-R56MT</b></p> 

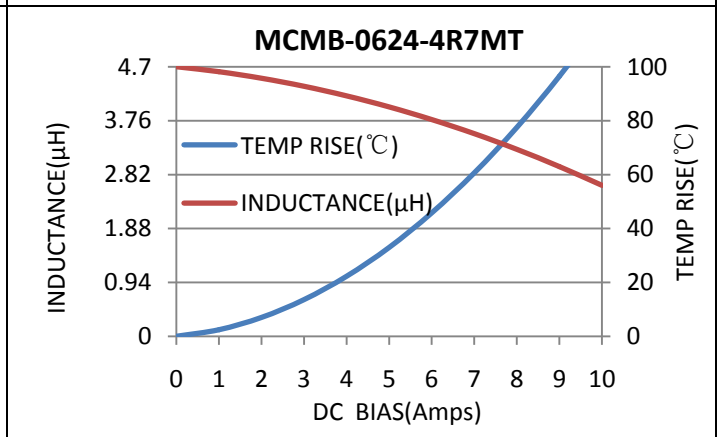
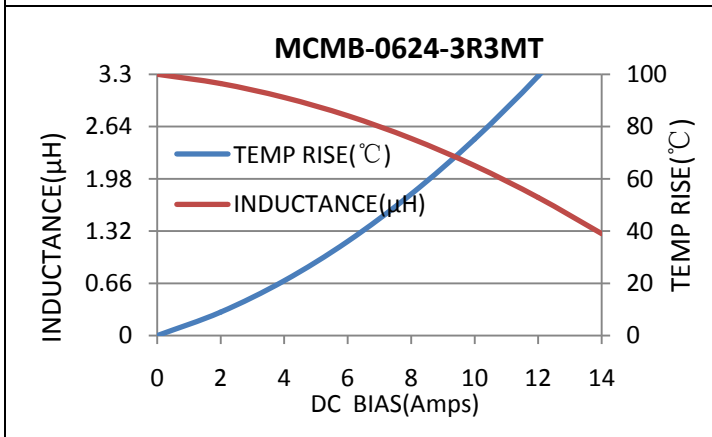
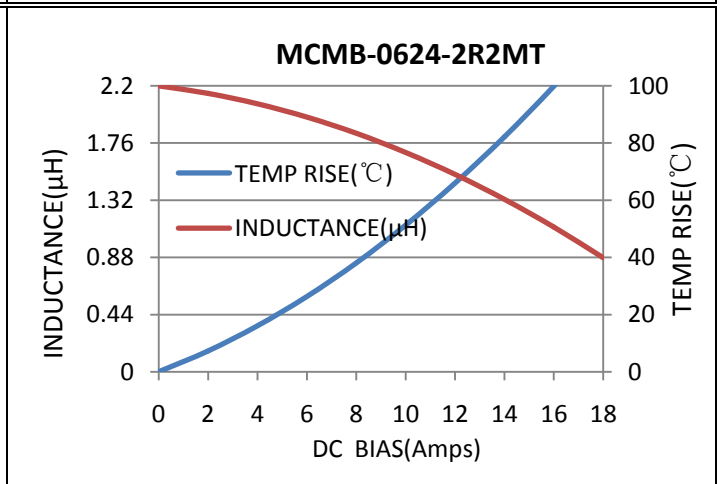
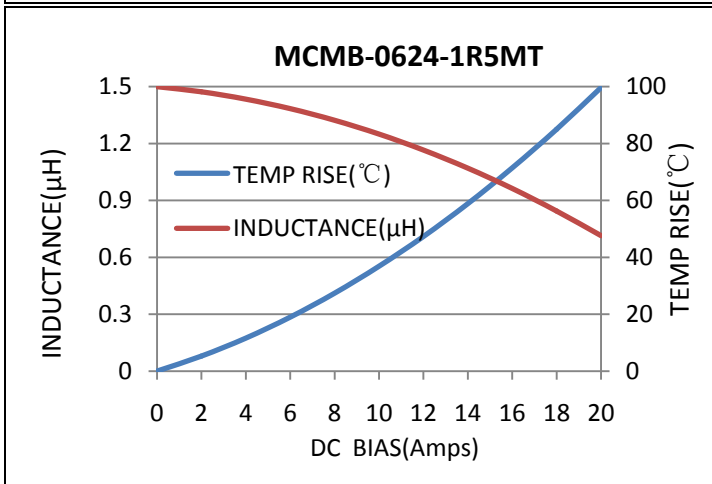
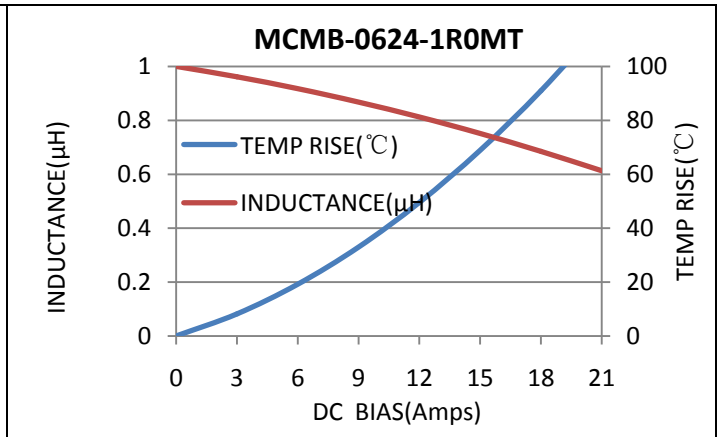
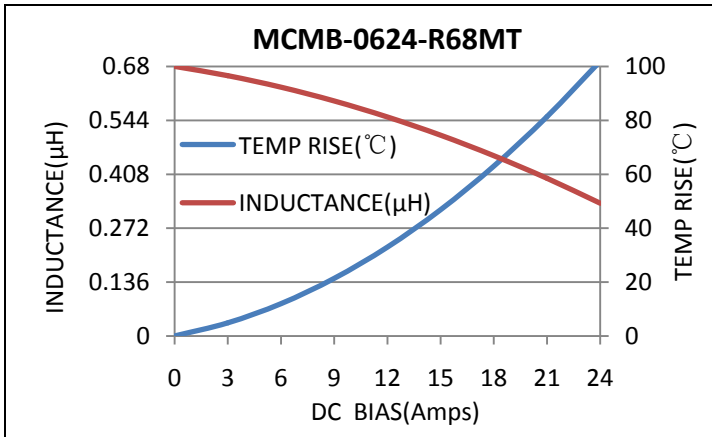

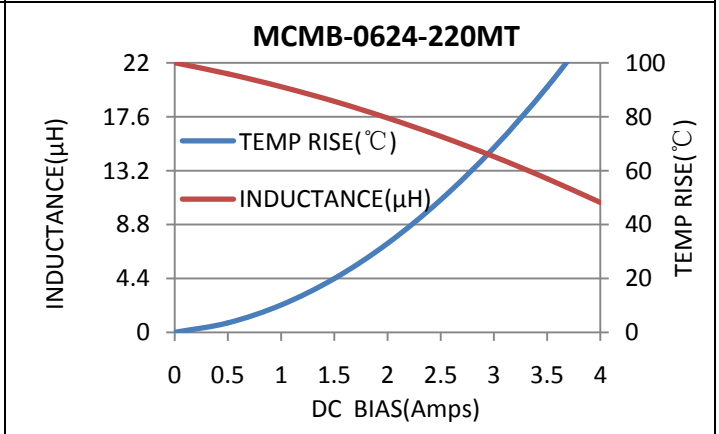
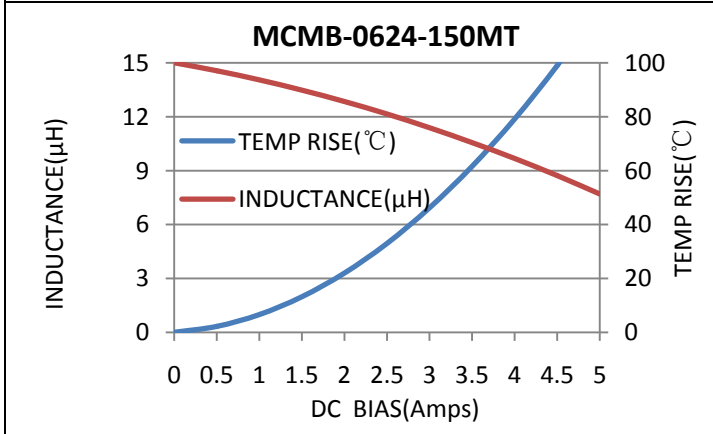
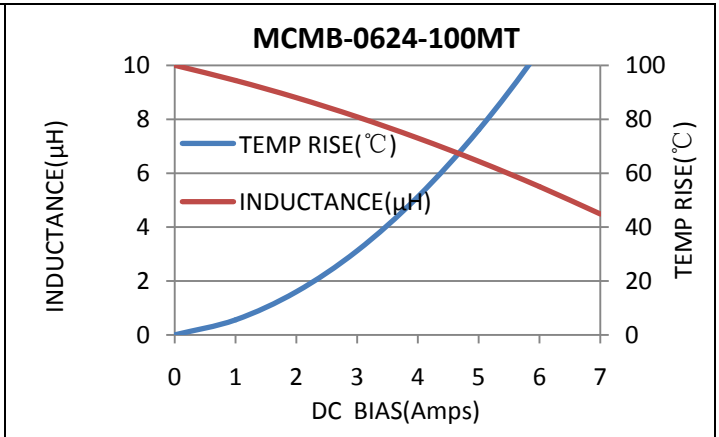
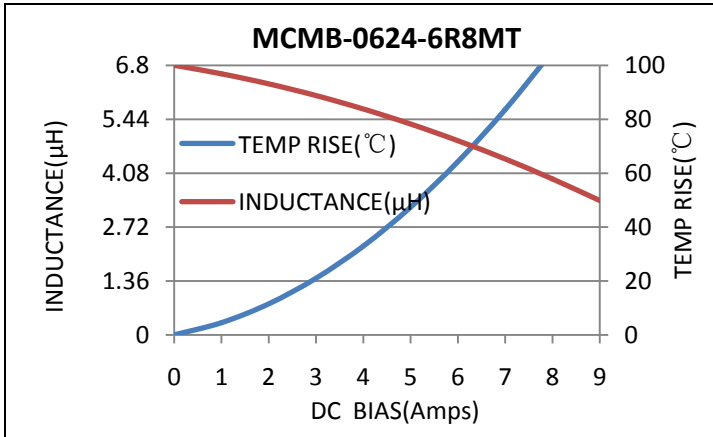

## Reliability and Test Condition

Mechanical Reliability		
Item	Specification and Requirement	Test Method
Solderability	The surface of terminal immersed shall be minimum of 95% covered with a new coating of solder	Solder heat proof: 1. Preheating: $160 \pm 10$ °C 2. Retention time: $245 \pm 5$ °C for $2 \pm 0.5$ seconds
Vibration	Inductance change: Within $\pm 10\%$ Without mechanical damage such as break	1. Vibration frequency: (10 Hz to 55 Hz to 10Hz) in 60 seconds as a period 2. Vibration time: Period cycled for 2 hours in each of 3 mutual perpendicular directions. 3. Amplitude: 1.5 mm max.
Shock	Inductance change: Within $\pm 10\%$ Without mechanical damage such as break	1. Peak value: 100 G 2. Duration of pulse: 11ms 3. 3 times in each positive and negative direction of 3 mutual perpendicular directions
Endurance Reliability		
Item	Specification and Requirement	Test Method
Thermal Shock	Inductance change: Within $\pm 10\%$ Without distinct damage in appearance	1. Repeat 100 cycles as follow: ( $-55 \pm 2$ °C; $30 \pm 3$ min) →(Room temp., 5 min) → ( $+125 \pm 2$ °C, $30 \pm 3$ min) → (Room temp., 5 min) 2. Recovery: $48 + 4 / -0$ hours of recovery under the standard condition after the test.
High Temperature Resistance	Inductance change: Within $\pm 10\%$ Without distinct damage in appearance	1. Environment condition: $85 \pm 2$ °C Applied Current: Rated current 2. Duration: $1000 + 4 / -0$ hours
Humidity Resistance	Inductance change: Within $\pm 10\%$ Without distinct damage in appearance	1. Environment condition: $60 \pm 2$ °C Humidity: 90–95% Applied Current: Rated current 2. Duration: $1000 + 4 / -0$ hours
Low Temperature Store	Inductance change: Within $\pm 10\%$ Without distinct damage in appearance	Store temperature: $-55 \pm 2$ °C, $1000 + 4 / -0$ hours
High Temperature Store	Inductance change: Within $\pm 10\%$ Without distinct damage in appearance	Store temperature: $+125 \pm 2$ °C, $1000 + 4 / -0$ hours

## Tape Packaging Dimensions

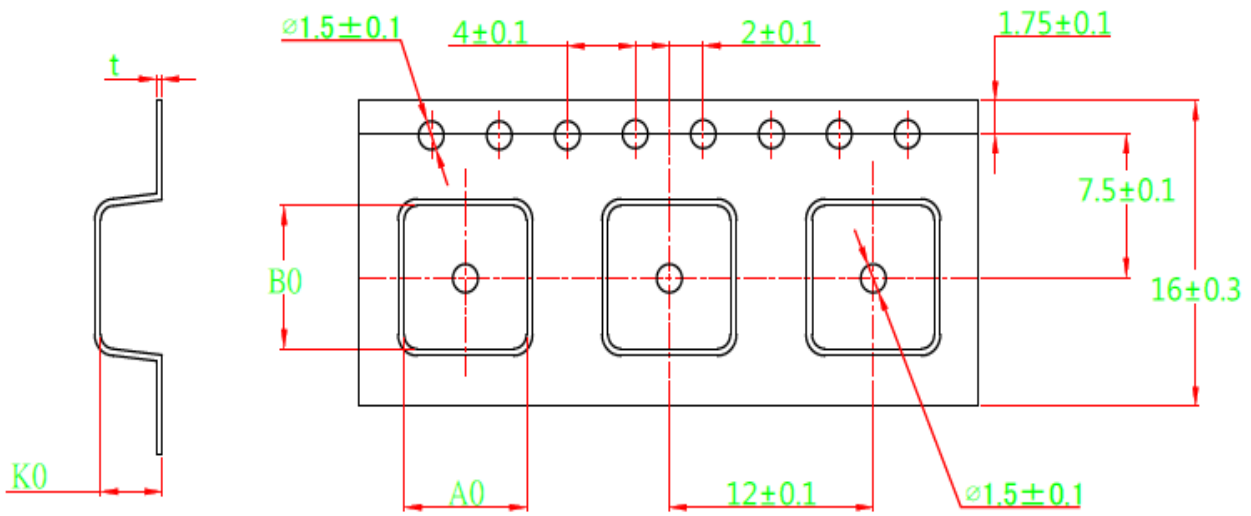

A0	B0	K0	t
7.2 $\pm$ 0.10	7.5 $\pm$ 0.10	3.6 $\pm$ 0.15	0.31 $\pm$ 0.05

## Reel Dimensions

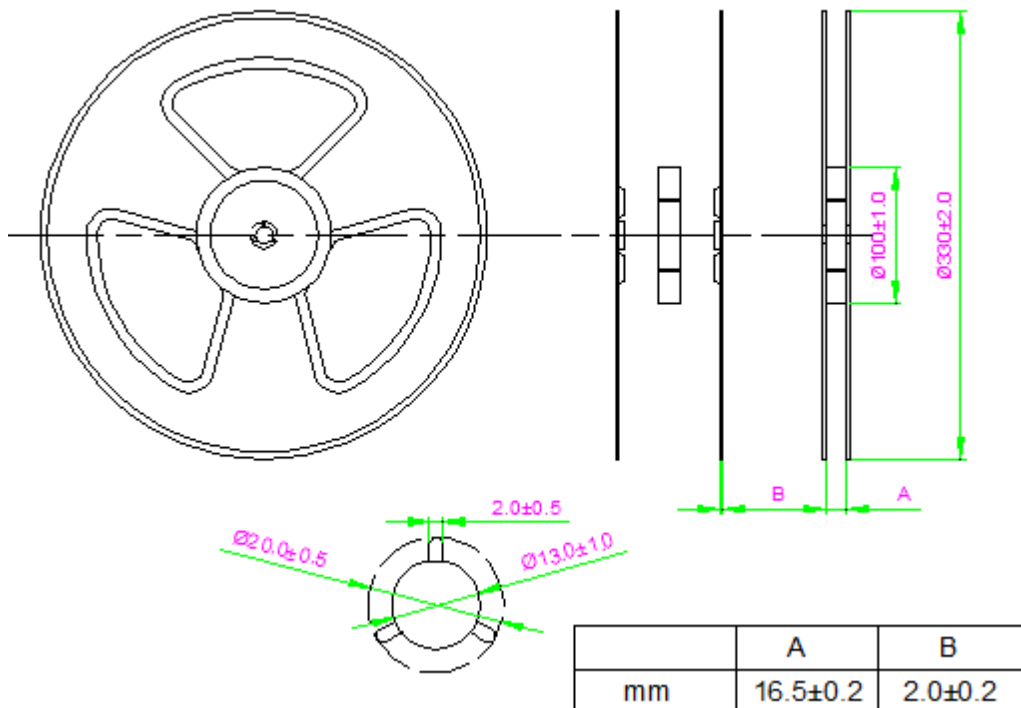

	A	B
mm	16.5 $\pm$ 0.2	2.0 $\pm$ 0.2

Packing Quantity: 1000pcs/Reel

## Recommendable reflow soldering

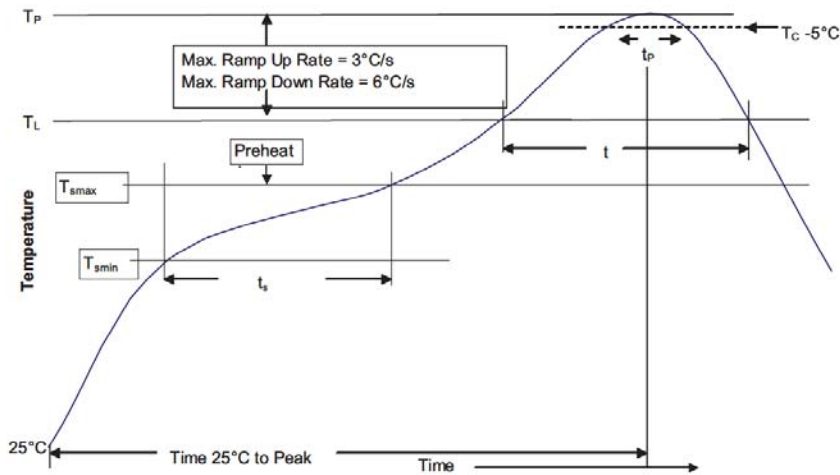

**Table 1 - Standard SnPb Solder ( $T_C$ )**

Package Thickness	Volume $\text{mm}^3$ <350	Volume $\text{mm}^3$ $\geq$ 350
<2.5mm	235°C	220°C
$\geq$ 2.5mm	220°C	220°C

**Table 2 - Lead (Pb) Free Solder ( $T_C$ )**

Package Thickness	Volume $\text{mm}^3$ <350	Volume $\text{mm}^3$ 350 - 2000	Volume $\text{mm}^3$ >2000
<1.6mm	260°C	260°C	260°C
1.6 - 2.5mm	260°C	250°C	245°C
>2.5mm	250°C	245°C	245°C

### Reference JDEC J-STD-020

Profile Feature	Standard SnPb Solder	Lead (Pb) Free Solder
Preheat and Soak		
• Temperature min. ( $T_{smin}$ )	100°C	150°C
• Temperature max. ( $T_{smax}$ )	150°C	200°C
• Time ( $T_{smin}$ to $T_{smax}$ ) ( $t_s$ )	60-120 Seconds	60-120 Seconds
Average ramp up rate $T_{smax}$ to $T_p$	3°C/ Second Max.	3°C/ Second Max.
Liquidous temperature ( $T_L$ )	183°C	217°C
Time at liquidous ( $t_L$ )	60-150 Seconds	60-150 Seconds
Peak package body temperature ( $T_p$ )*	Table 1	Table 2
Time ( $t_p$ )** within 5 °C of the specified classification temperature ( $T_C$ )	20 Seconds**	30 Seconds**
Average ramp-down rate ( $T_p$ to $T_{smax}$ )	6°C/ Second Max.	6°C/ Second Max.
Time 25°C to Peak Temperature	6 Minutes Max.	8 Minutes Max.

\* Tolerance for peak profile temperature ( $T_p$ ) is defined as a supplier minimum and a user maximum.

\*\* Tolerance for time at peak profile temperature ( $t_p$ ) is defined as a supplier minimum and a user maximum.