

产品规格书

SAP料号 SAP part No. : 10201T6812F350XXA0
产品型号 Product P/N : SK6812MINIRGBW-XX-P6-A-000
样品号 SAP part No. : /
客户料号 Client P/N : NA
版本号 Version No. : A/1
时 间 Sending Date : 2025-07-22

Customer approval			Opsco approval		
CHECK	APPROVE	CONFIRM	DRAW	CHECK	APPROVE
			张维友	周凯	朱更生
Stamp			Stamp		



*使用我司产品前, 请检索我司官网核对规格书版本, 产品规格书版本更新, 恕不能及时相告, 请以官网最新资料为准。

*Before using our products, please search our official website to verify the version of the specification sheet. The product specification sheet version is updated, and we apologize for any inconvenience caused. Please refer to the latest information on the official website for accuracy.

*该版权及产品最终解释权归东莞市欧思科光电科技有限公司所有, 如有特殊规格要求, 请联系我司工程人员。

*The copyright and final interpretation rights of the product belong to Dongguan OPSCO Optoelectronic Technology Co., Ltd. If there are special specification requirements, please contact our engineering personnel.

目 录 Catalogue

1、产品概述 Overview	3
2、主要应用 Main applications	3
3、产品命名一般说明 General instructions for product naming	4
3.1.产品代码说明 Product code description.....	4
4、机械尺寸 Mechanical dimensions	5
5、引脚功能说明 Pin Function Description	5
6、PCB建议焊盘尺寸 PCB recommended pad size	6
7、IC极限参数 IC limit parameter	6
8、RGBW LED光电参数 RGBW LED Optoelectronic parameters	7
9、IC电气参数 IC electrical parameters	7
10、控制器建议数据传输时间 Suggested data transmission tme.....	8
11、数据传输方式 Data transmission method	8
12、时序波形图 Time series waveform diagram	9
13、32bit数据结构 32bit data structure	9
14、典型应用电路 Typical application circuit	10
15、白光色温等级及CIE颜色等级划分White light color temperature level and CIE color level classification.....	11~15
16、光电特性 Photoelectric characteristic	16
17、包装标准 Packaging standards	17
18、可靠性测试 Reliability testing	18

1.产品概述 Product overview:

- 工作电压：5V@8mA(OUT GRB) ， 5V@16.5mA(OUT W) ；
Forward voltage: 5V@8mA(OUT GRB) ， 5V@16.5mA(OUT W) ；

- 发光角度：120° ；

Typical view angle 50%:120 ° ；

- 胶体颜色：RGB半透明+W黄色荧光胶；

RGB Lens color: translucent + W Yellow fluorescent adhesive ；

- 内置复位电路，上电不亮灯；

Built-in reset circuit, power does not light ；

- 灰度调节：256级；

Grayscale adjustment : 256 levels ；

- 单线归零码传输协议，可无限级联；

Single-line zero code transmission protocol, can be infinite cascade ；

- 数据传输频率可达800Kbps，当刷新速30帧/秒时，级联数小于1024点；

The data transmission frequency can reach 800Kbps, and when the refresh speed is 30 frames per second, the cascade number is less than 1024 points. ；

- 湿敏等级：5a ；

MSL : 5a ；

- 静电ESD：2KV ；

ESD level: 2KV ；

- 符合RoHS REACH ；

RoHS and REACH-compliant.

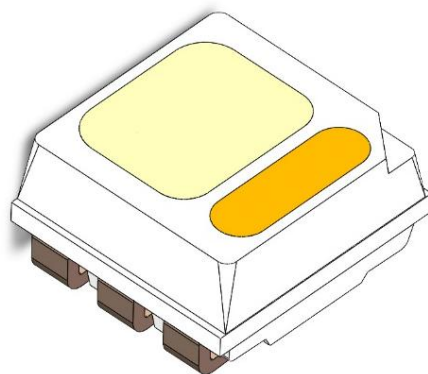

2.主要应用 Main applications:

- 消费电子产品

Consumer electronics

- 电竞产品

Esports products

3. 产品命名一般说明 General instructions for product naming :

SK 6812 MINI RGBW-XX-P6-A-000

① ② ③ ④ ⑤ ⑥ ⑦

①	②	③	④	⑤
系列 Series	Ic系列与电流代码 IC series and current codes	封装外形 Package outline dimensions	颜色代码 Colour codes	色温代码 TC code
默认为RGB晶片与IC集成在一起 Default to RGB chip integrated with IC	6812 : 指68系列IC,RGB:8mA电流 ; W:16.5mA电流版本 Refers to the 68 series IC; OUT R/G/B:8mA,OUT W:16.5mA current version	MINI:指封装尺寸为3.7*3.5*1.9mm The package size is 3.7*3.5*1.9mm	RGBW: R:615-625nm G:525-535nm B:465-475nm W:White	XX: AB:1700-1900K BW:5500-10000K NW:3800-4200K WS:2800-3200K GW:2380-2700K

⑥	⑦
引脚数量 Number of pins	内部编码 Internal code
P6:6PINS	A-000:内部编码 Internal code

3.1.产品代码说明 Product code description:

序号 No	产品型号 Model	样品号 Sample No	SAP 代码 SAP code	色温 Colour temperature
1	SK6812MINIRGBW-AB-P6-A-000	OP00309C-000	10201T6812F35000A0	1700-1900K
2	SK6812MINIRGBW-BW-P6-A-000	OP000309-000	10201T6812F35002A0	5500-10000K
3	SK6812MINIRGBW-NW-P6-A-000	OP00309A-000	10201T6812F35006A0	3800-4200K
4	SK6812MINIRGBW-WS-P6-A-000	OP00309B-000	10201T6812F35008A0	2800-3200K
5	SK6812MINIRGBW-GW-P6-A-000	OP00309A-001	10201T6812F35009A0	2380-2700K

注 : 色温误差±100K , Ra>80 ±2

Note: Color temperature : ±100K, Ra>80 ±2

4.机械尺寸 Mechanical dimensions:

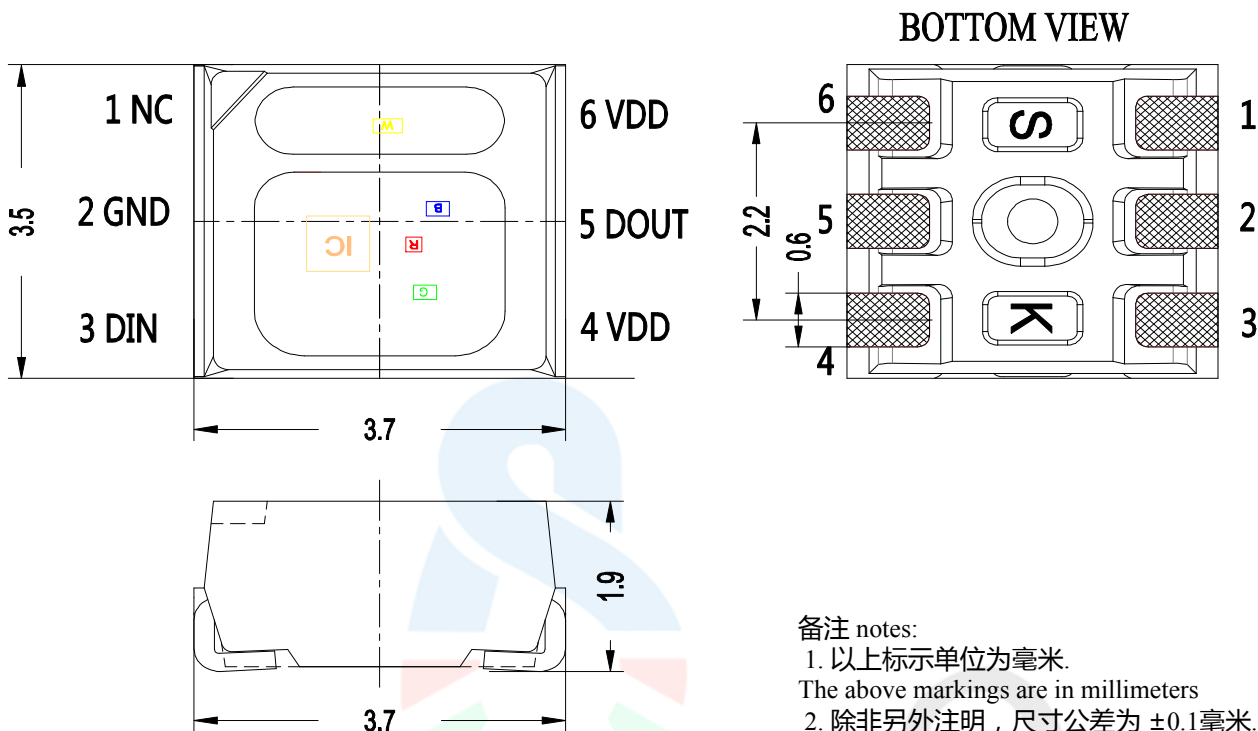

备注 notes:

1. 以上标示单位为毫米。
The above markings are in millimeters
2. 除非另外注明，尺寸公差为 ±0.1毫米。
Unless otherwise specified, the dimensional tolerance is ± 0.1 millimeters

5. 引脚功能说明 Pin Function Description :

序号 Serial number	符号 Symbol	管脚名 Pin name	功能描述 Function description
1	NC	空脚 Empty feet	此脚不能做任何电路设计 This empty foot cannot be used for any circuit design
2	GND	地 Grounds	电源接地 Power grounding
3	DIN	数据输入 Data input	控制数据信号输入 Control data signal input
4	VDD	电源 Power supply	供电管脚 Power supply pins
5	DOUT	数据输出 Data output	控制数据信号输出 Control data signal output
6	VDD	电源 Power supply	供电管脚 Power supply pins

6.PCB建议焊盘尺寸 PCB recommended pad size :

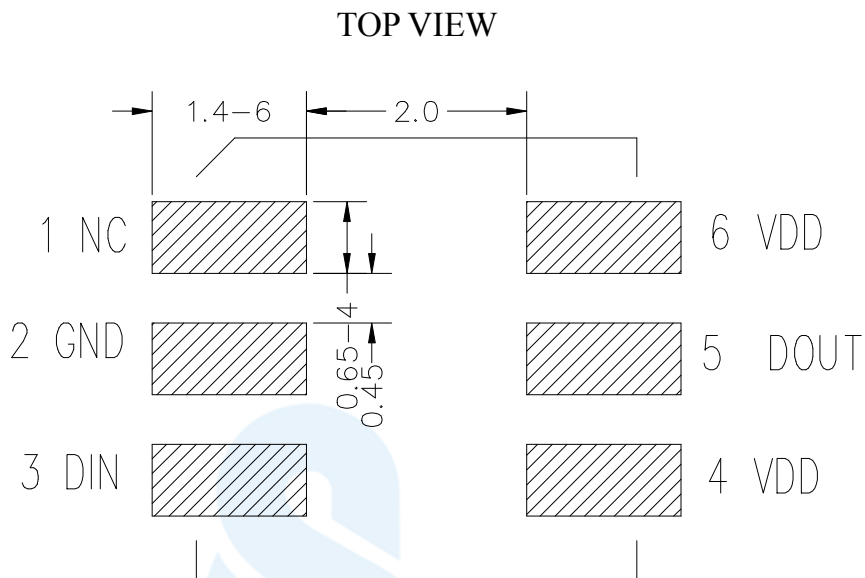

7.IC极限参数 IC limit parameter : (Ta=25°C)

参数 Parameter	符号 Symbol	范围 Range	单位 Unit
逻辑电源电压 Working voltage	V _{DD}	+3.7 ~ +5.5	V
工作温度 Operation temperature	T _{opt}	-40~+80	°C
储存温度 Storage temperature	T _{stg}	-40~+80	°C
ESD耐压 (人体模式) ESD withstand voltage (human mode)	V _{ESD}	2K	V

8. RGB LED 光电参数 Optoelectronic parameters :

颜色 Colour	SK6812MINIRGBW-XX-P6-A-000 R/G/B:8mA W:16.5mA		
	波长 Wavelength (nm)	色温 Colour temperature (K)	亮度 Brightness (mcd)
红色 (RED)	615-625	/	200-385
绿色 (GREEN)	525-535	/	580-1050
蓝色 (BLUE)	465-475	/	140-280
AB(Amber)	/	1700-1900K	1500-2100
BW(Blue White)	/	5500-10000	1800-2525
NW(Natural White)	/	3800-4200K	1800-2525
WS(Warm White)	/	2800-3200K	1800-2525
GW(Gold White)	/	2380-2700K	1800-2525

注：亮度误差±10%，波长误差±1.0nm，色温误差±100K；

Note : Luminous Intensity: ±10%Iv, Dominant Wavelength: ±1.0nm , Color temperature : ±100K ;

9. IC电气参数 IC electrical parameters : (TA=25°C)

参数 Parameter	符号 Symbol	最小 Minimum	典型 Typical	最大 Maximum	单位 Unit	测试条件 Test conditions
工作电压 Chip input voltage	V _{DD}	3.7	---	5.5	V	---
信号输入翻转阈值 Signal input flip threshold	V _{IH}	0.65*VDD	---	---	V	+VDD=5.0V
	V _{IL}	---	---	0.35*VDD	V	
B/G/R输出驱动电流 B/G/R output drive current	I _{DOUT}	---	8	---	mA	VDD=5V VDS=1.0V
W输出驱动电流 W output drive current		---	16.5	---		
PWM频率 PWM frequency	F _{PWM}	---	4.0	---	KHz	IOUTR/G/B=8mA , IOUTW=16.5mA , OUT 端口串接 200Ω 电阻至 VDD OUT port connects 200Ω resistor to VDD in series
静态功耗 Static power consumption	I _{DD}	---	0.29	---	mA	VDD =5V IOUT "OFF"
数据传输速率 Transfer rate	F _{DIN}	---	800	---	Kbps	---

10. 控制器建议数据传输时间 Suggested data transmission time :

时序表名称 Timeline name	Min.	实际值 Actual value	Max.	单位 Unit
T 码元周期 Symbol period	1.20	--	--	μs
T0H 0码, 高电平时间 0 code, high-level time	0.25	0.30	0.40	μs
T0L 0码, 低电平时间 0 code, low-level time	0.80	--	--	μs
T1H 1码, 高电平时间 1 code, high-level time	0.65	0.75	1.00	μs
T1L 1码, 低电平时间 1 code, low-level time	0.20	--	--	μs
Reset Reset码, 低电平时间 Reset code, low-level time	>200	--	--	μs

1. 协议采用单极性归零码，每个码元必须有低电平，本协议的每个码元起始为高电平，高电平时间宽度决定“0”码或“1”码。

The protocol adopts unipolar zeroing code, and each symbol must have a low level. Each symbol in this protocol starts with a high level, and the duration of the high level determines the "0" or "1" code.

2. 书写程序时，码元周期最低要求为1.2μs。

When writing a program, the minimum required code period is 1.2 μ s.

3. “0”码、“1”码的高电平时间需按照上表的规定范围，“0”码、“1”码的低电平时间要求小于20μs。

The high-level time of "0" and "1" codes should be within the specified range in the table above, and the low-level time of "0" and "1" codes should be less than 20 μ s.

11. 数据传输方式 Data transmission method : (Ta=25°C)

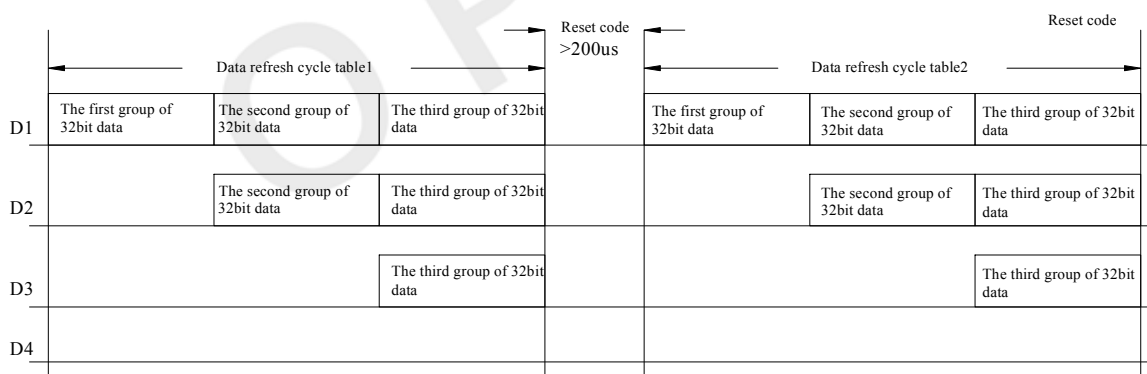

注Note：其中D1为MCU端发送的数据，D2、D3、D4为级联电路自动整形转发的数据。

Among them, D1 is the data sent by the MCU end, and D2, D3, and D4 are the data automatically shaped and forwarded by the cascaded circuit.

12.时序波形图 Time series waveform diagram : (Ta=25°C)

输入码型 Input code type :

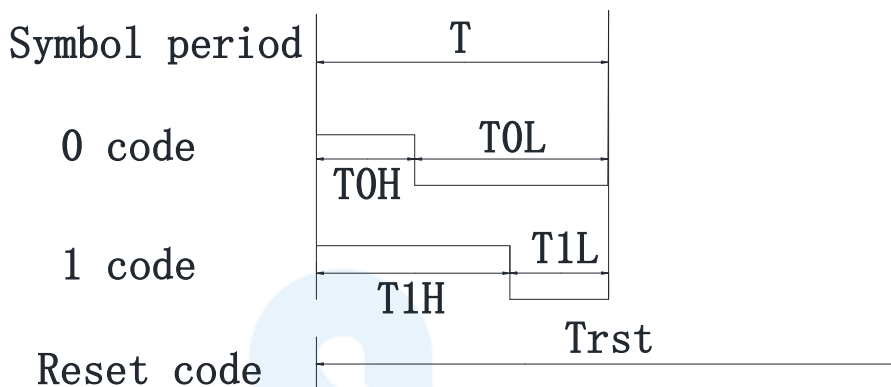

连接方式 Connection method :

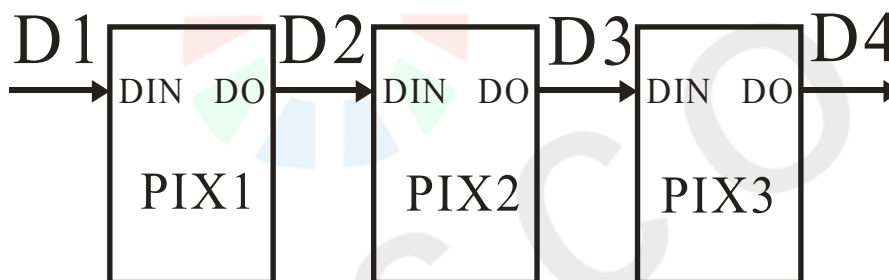

13.32bit数据结构 32 bit data structure : (Ta=25°C)

G7	G6	G5	G4	G3	G2	G1	G0	R7	R6	R5	R4
R3	R2	R1	R0	B7	B6	B5	B4	B3	B2	B1	B0
W7	W6	W5	W4	W3	W2	W1	W0				

注Note : 高位先发 , 按照GRBW的顺序发送数据(G7 → G6 →.....W0)

High bit first send, send data in GRBW order (G7 → G6 →.... W0)

14.应用电路原理图 Principles of Applied Circuits :

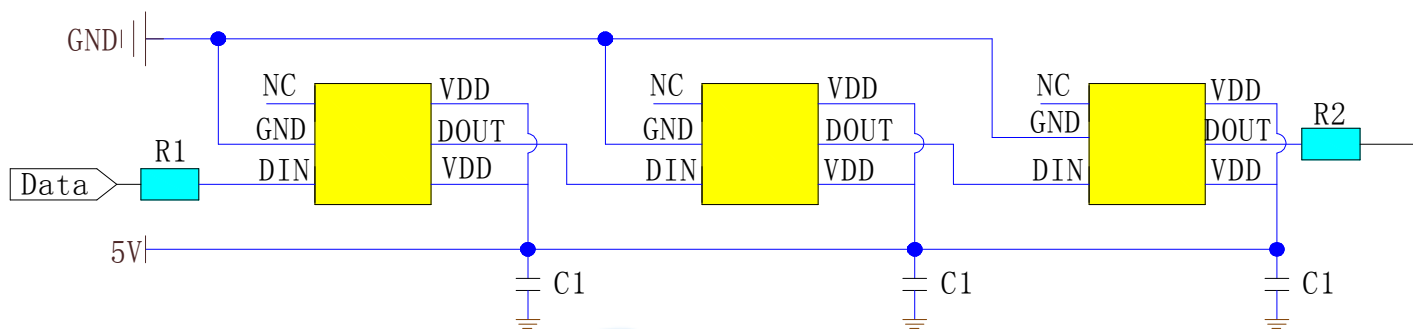

在实际应用电路中，为防止产品在测试时带电插拔产生的瞬间高压损伤IC内部信号输入输出引脚，应在信号输入及输出端串接保护电阻。此外，为了使各IC芯片间更稳定工作，各灯珠间的退偶电容则必不可少；

In practical application circuits, to prevent instantaneous high voltage damage to the internal signal input and output pins of the IC caused by live plugging and unplugging during testing, protective resistors should be connected in series at the signal input and output terminals. In addition, in order to ensure more stable operation between IC chips, the decoupling capacitance between each LED is essential;

应用一：用于软灯条或硬灯条的，灯珠间传输距离短的，建议在信号输入输出端各串接保护电阻，即R1、R2约500欧，以实际测试信号数据为准；

Application 1: For soft light strips or hard light strips, the transmission distance between the lamp beads is short. It is recommended to connect the protective resistors in series at the signal input and output ends, that is, about 500 ohms for R1 and R2, subject to the actual test signal data;

应用二：用于模组或一般异形产品，灯珠间传输距离长，因线材及传输距离不同，在信号两端串接的保护电阻会略有不同；以实际使用情况定。

Application 2: Used for modules or general shaped products. The transmission distance between lamp beads is long. Due to different wire materials and transmission distances, the protective resistance of the signal line connected in series at both ends will be slightly different; Based on actual usage.

15. 白光色温等级及CIE颜色等级划分 (指1931 CIE色度图) White light color temperature level and CIE color level classification (referring to the 1931 CIE chromaticity chart)

CIE 色品坐标系 (BW) CIE chromaticity coordinate system (BW)

Name	X1	Y1	X2	Y2	X3	Y3	X4	Y4	TC
AB	0.5626	0.4270	0.5449	0.4314	0.5528	0.4175	0.5704	0.4132	1700-1900K

AB 白光分级形式 AB light grading form



CIE 色品坐标系(BW) CIE chromaticity coordinate system (BW)

Name	X1	Y1	X2	Y2	X3	Y3	X4	Y4	TC
BW-A	0.2928	0.2822	0.2802	0.2895	0.2885	0.3007	0.3011	0.2934	8300-10000K
BW-B	0.3011	0.2934	0.2885	0.3007	0.302	0.3189	0.3147	0.3116	7000-8300K
BW-C	0.3147	0.3116	0.302	0.3189	0.3186	0.3412	0.3313	0.3339	6000-7000K
BW-D	0.3313	0.3339	0.3186	0.3412	0.3326	0.36	0.3449	0.3522	5500-6000K

BW 白光分级形式 BW White light grading form

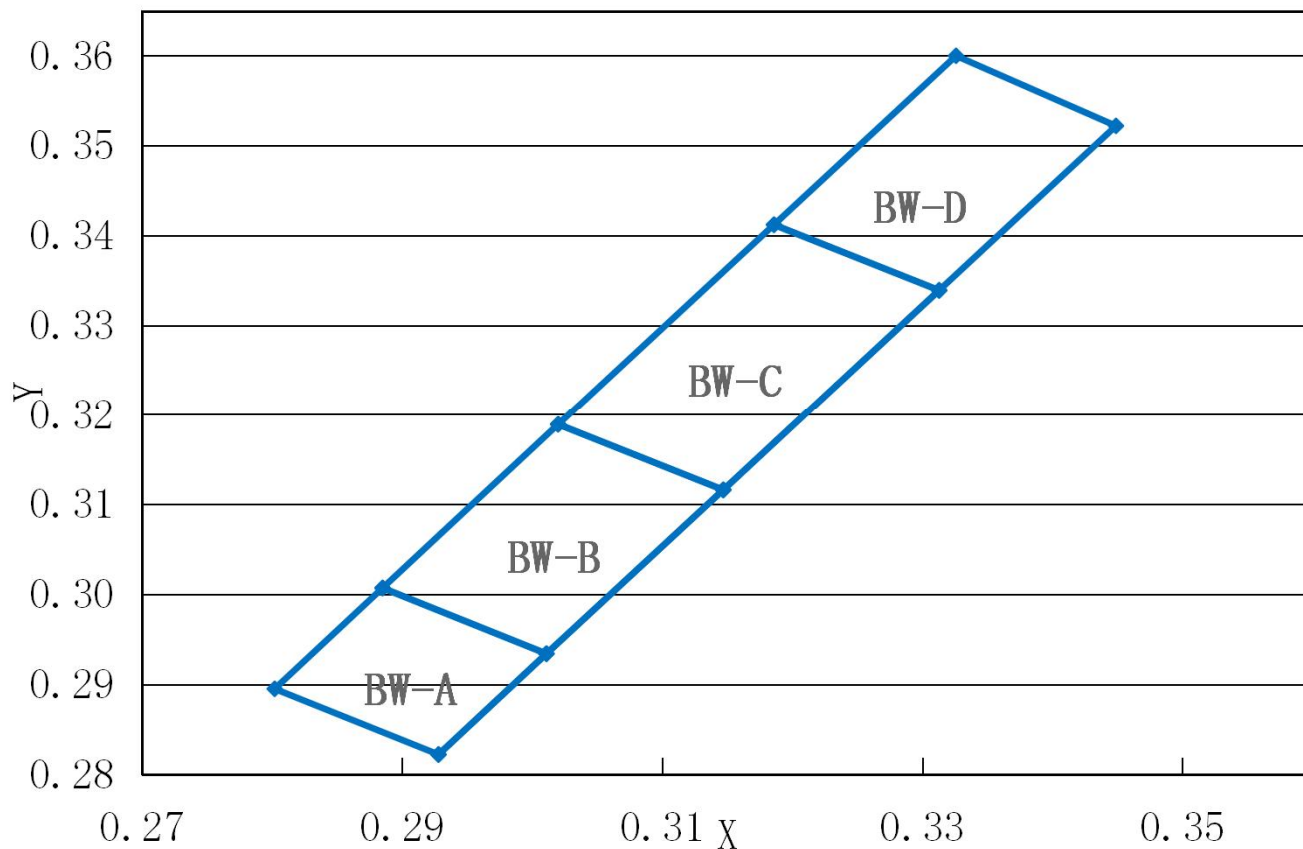

CIE 色品坐标系(NW) CIE chromaticity coordinate system (NW)

Name	X1	Y1	X2	Y2	X3	Y3	X4	Y4	TC
NA-A	0.3630	0.3460	0.3510	0.3550	0.3590	0.3640	0.3700	0.3560	4200-4500K
NB-A	0.3700	0.3560	0.3590	0.3640	0.3660	0.3720	0.3770	0.3640	4100-4400K
NC-A	0.3770	0.3640	0.3660	0.3720	0.3800	0.3872	0.3910	0.3805	4050-4250K
ND-A	0.3910	0.3805	0.3800	0.3872	0.3870	0.3950	0.3980	0.3890	4000-4200K
NE-A	0.3980	0.3890	0.3870	0.3950	0.3950	0.4040	0.4050	0.3980	3900-4150K

NW 白光分级形式 NW White light grading form

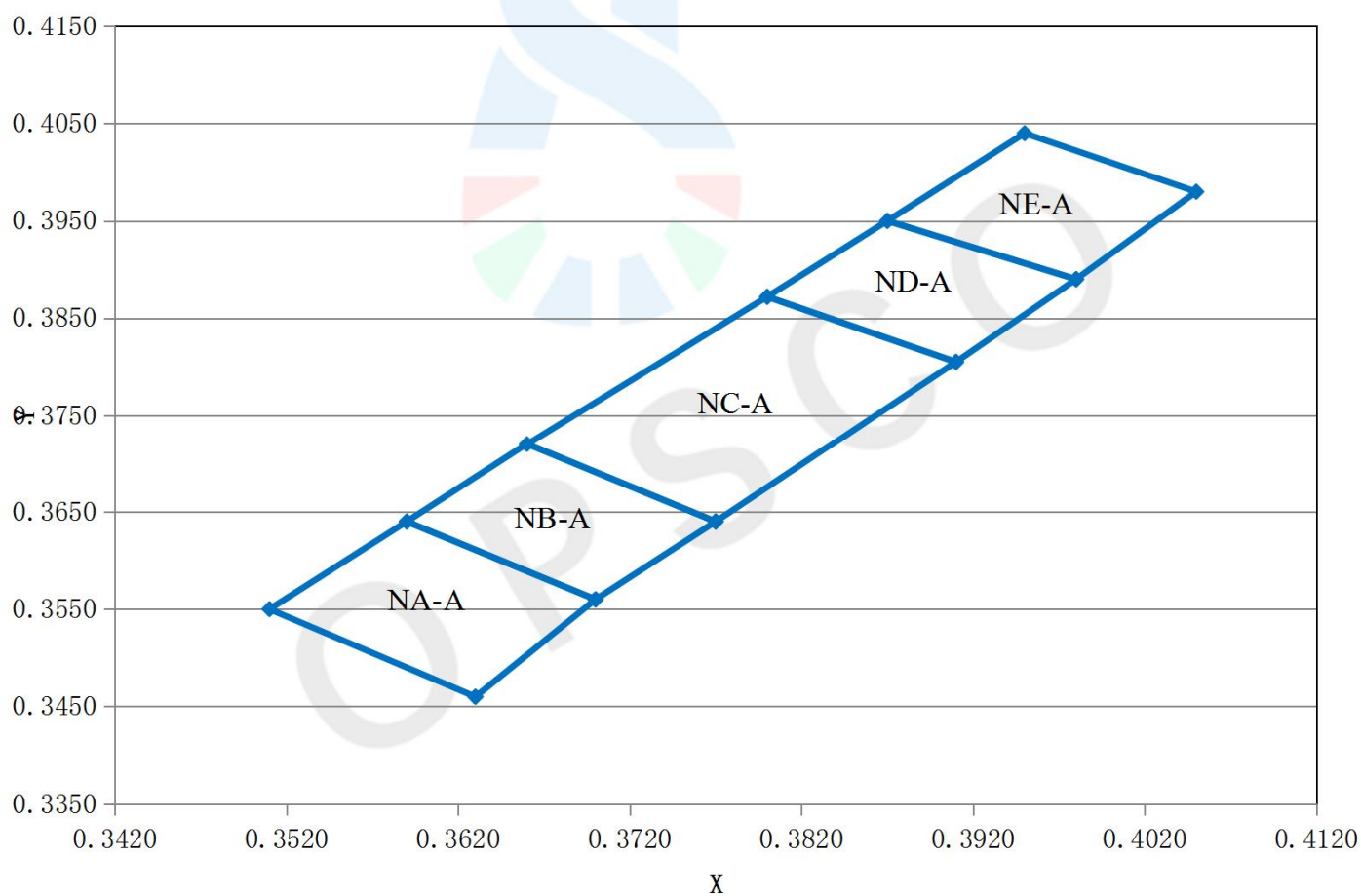

CIE 色品坐标系(WS) CIE chromaticity coordinate system (WS)

Name	X1	Y1	X2	Y2	X3	Y3	X4	Y4	TC
K1-A	0.4344	0.4032	0.4221	0.3984	0.4147	0.3814	0.4260	0.3853	3000-3200K
K2-A	0.4430	0.4212	0.4299	0.4165	0.4221	0.3984	0.4344	0.4032	3000-3200K
K3-A	0.4562	0.4260	0.4430	0.4212	0.4344	0.4032	0.4465	0.4071	2850-3000K
K4-A	0.4465	0.4071	0.4344	0.4032	0.4260	0.3853	0.4373	0.3893	2850-3000K
L1-A	0.4586	0.4103	0.4465	0.4071	0.4373	0.3893	0.4483	0.3918	2700-2850K
L2-A	0.4687	0.4289	0.4562	0.4260	0.4465	0.4071	0.4586	0.4103	2700-2850K

WS 白光分级形式 WS White light grading form

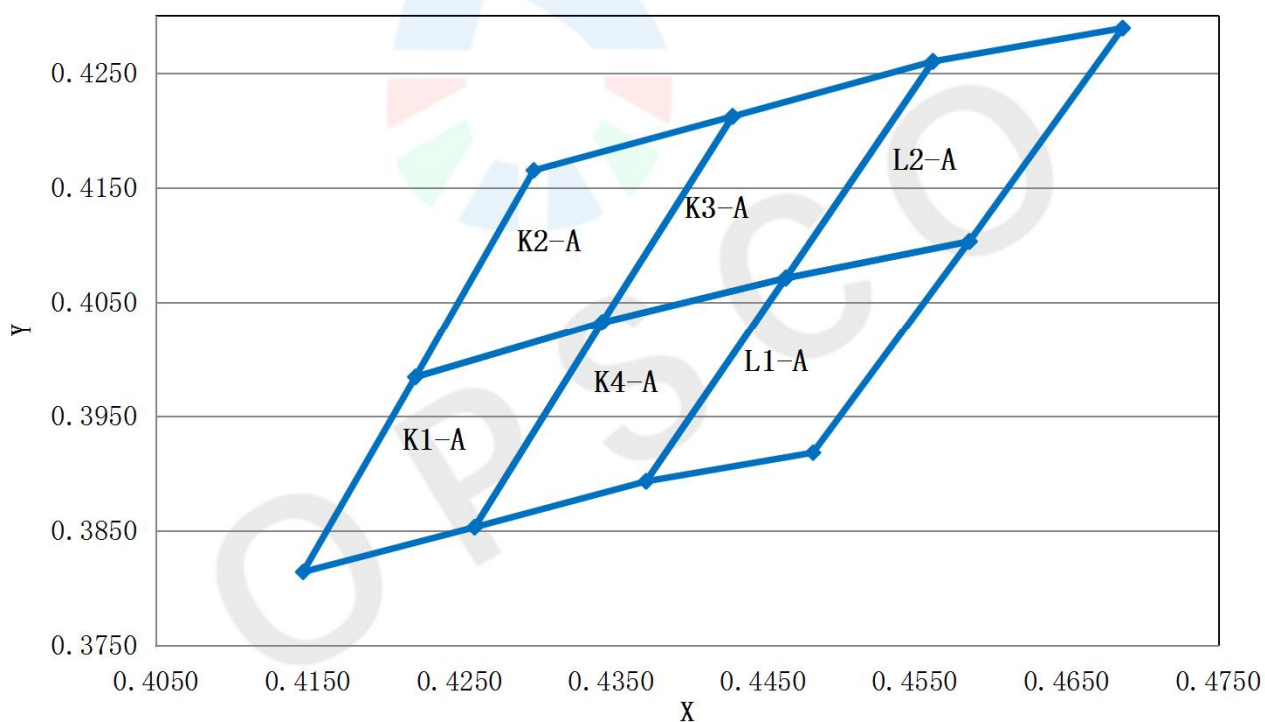

CIE 色品坐标系(WS) CIE chromaticity coordinate system (WS)

Name	X1	Y1	X2	Y2	X3	Y3	X4	Y4	TC
GA	0.4633	0.3937	0.4553	0.4039	0.4619	0.4088	0.4699	0.3987	2600-2700K
GB	0.4699	0.3987	0.4619	0.4088	0.4686	0.4137	0.4765	0.4036	2500-2650K
GC	0.4765	0.4036	0.4686	0.4137	0.4752	0.4185	0.4830	0.4085	2450-2600K
GD	0.4830	0.4085	0.4752	0.4185	0.4818	0.4234	0.4896	0.4135	2400-2550K
GE	0.4896	0.4135	0.4818	0.4234	0.4885	0.4282	0.4962	0.4184	2380-2500K

GW 白光分级形式 WS White light grading form

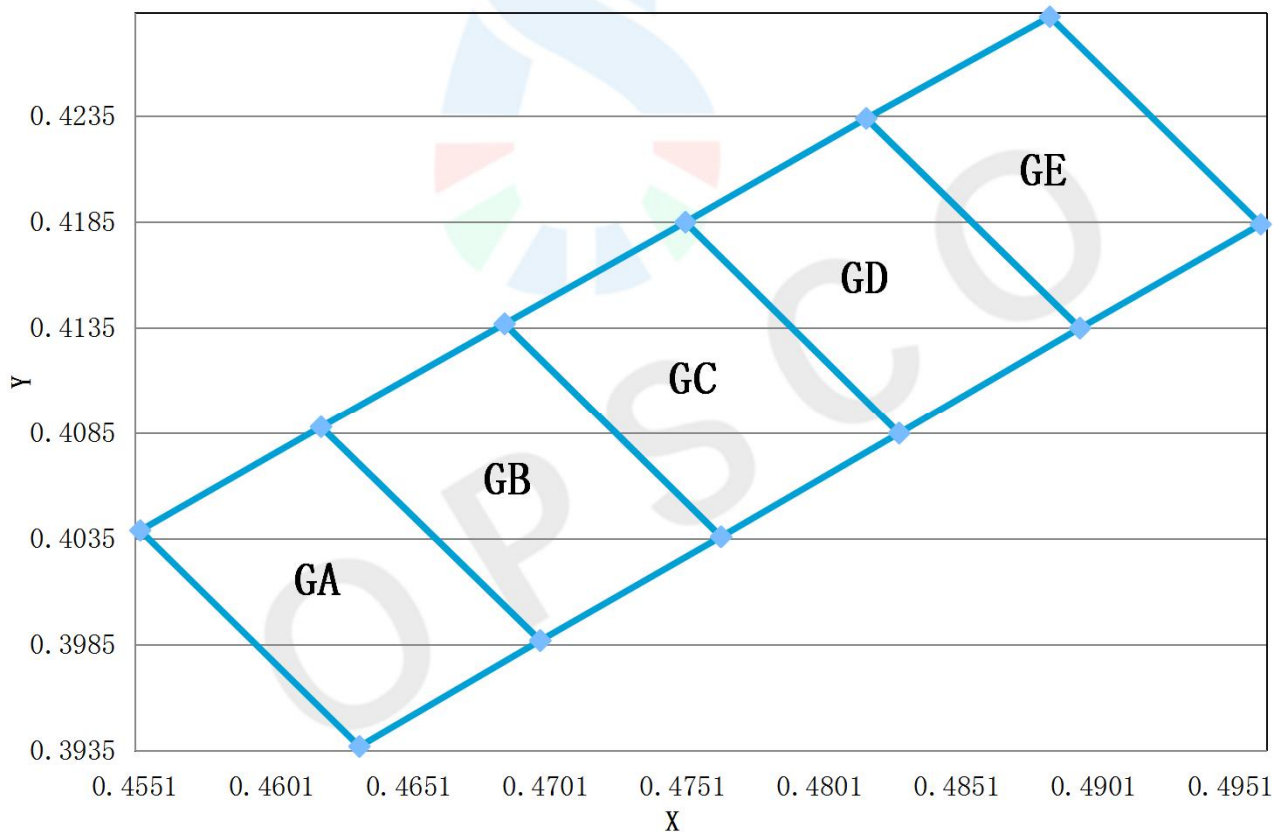

16. 光电特性 Photoelectric characteristic :

相对光通量与正向电流的关系
 The relationship between relative luminous flux and forward current

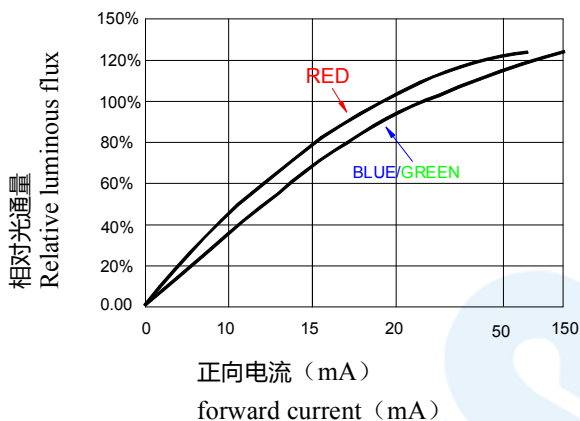

正向电压与正向电流的关系
 The relationship between forward voltage and forward current

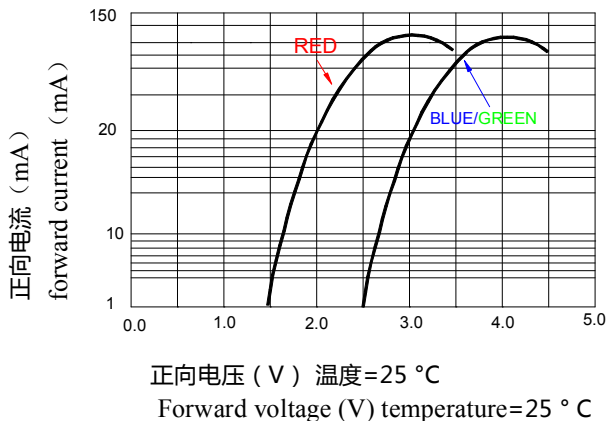

焊盘温度与光通量输出的相对关系
 The relative relationship between pad temperature and luminous flux output

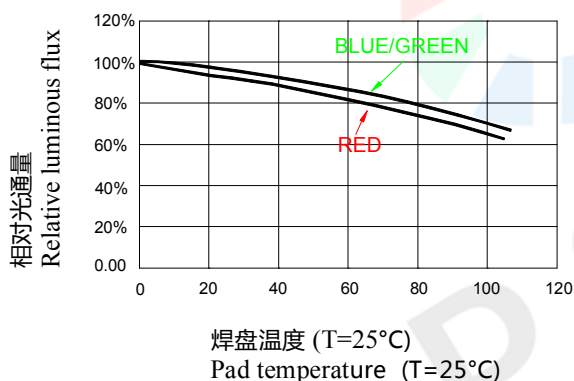

波长特性
 Wavelength characteristics

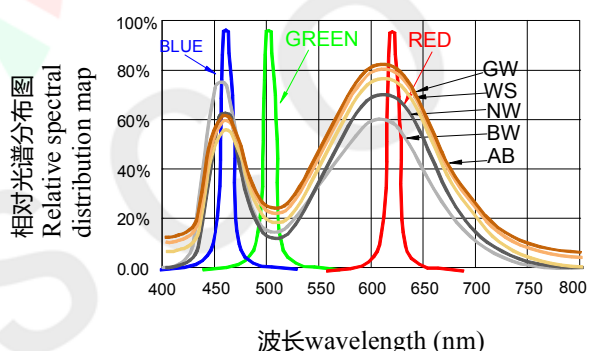

焊盘温度与正向电流的相对关系
 The relative relationship between pad temperature and forward current

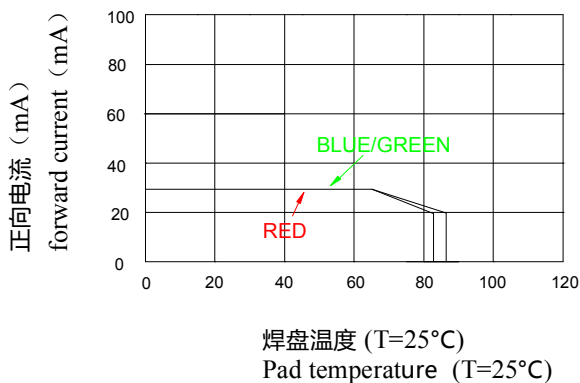

典型的辐射方向图 120°
 Typical radiation pattern 120°

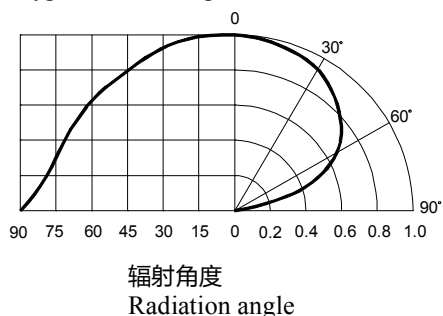

17. 包装标准 Packaging standards :

SK6812MINIRGBW-XX-P6-A-000

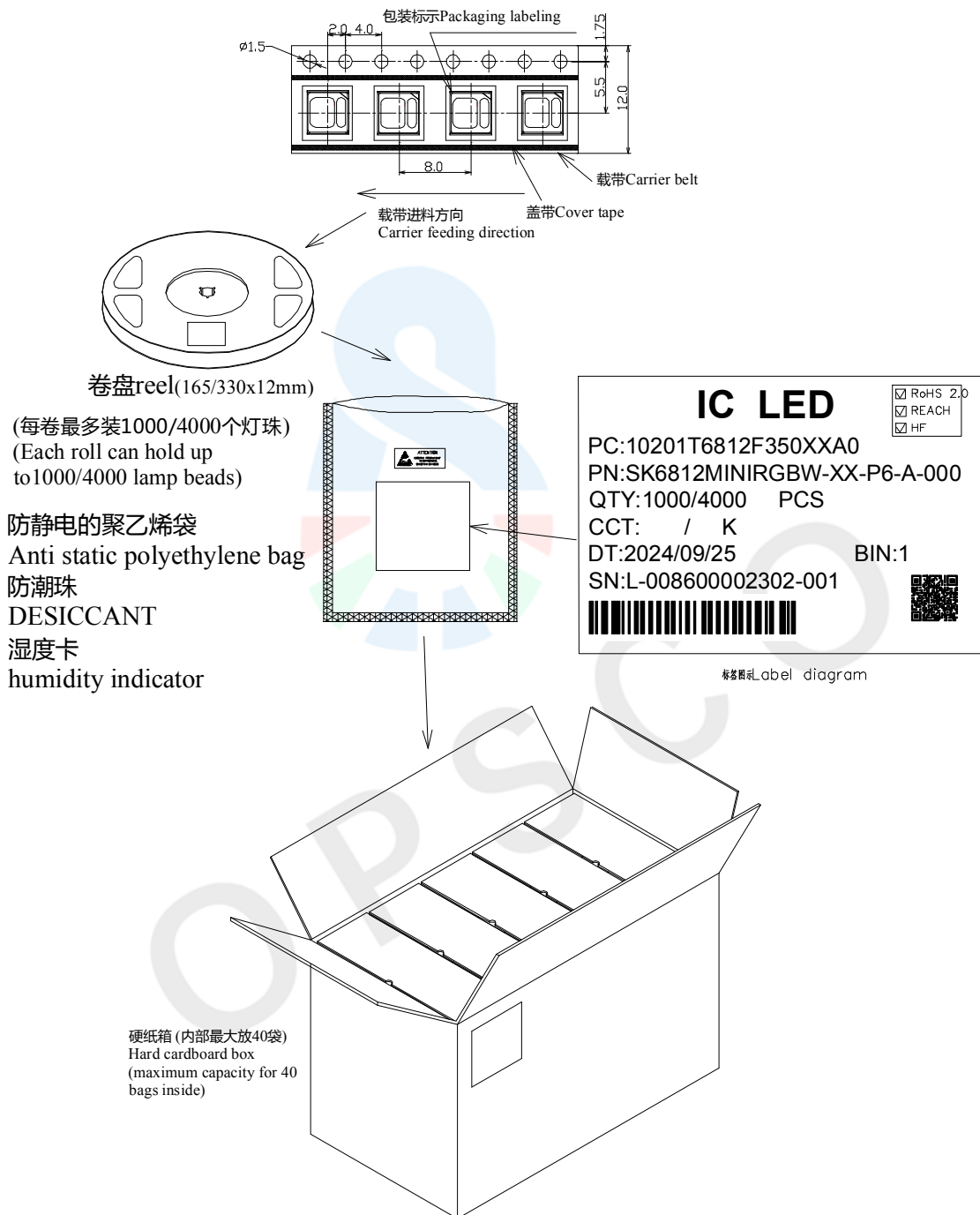

表面贴装LED采用卷盘包装，LED在用普通或防静电袋包装后再装在纸箱中。纸箱用于保护运输途中LED不受机械冲击，纸箱不防水，因此请注意防潮防水。

Surface mounted LEDs are packaged in rolls, and the LEDs are packaged in regular or anti-static bags before being packed in cardboard boxes. The cardboard box is used to protect the LED from mechanical impact during transportation. The cardboard box is not waterproof, so please pay attention to moisture-proof and waterproof.

18. 可靠性测试 Reliability testing:

序号 Serial number	实验项目 Pilot projects	实验条件 Experimental condition	参考标准 Reference standards	判断 Determine
1	冷热冲击 Thermal Shock	100 ± 5°C ~ -40°C ± 5°C 15min~15min 100cycles	MIL-STD-202G	0/22
2	高温储藏 High temperature storage	Ta= +100°C 1000hrs	JEITA ED-4701 200 201	0/22
3	低温储藏 Low temperature storage	Ta= -40°C 1000hrs	JEITA ED-4701 200 202	0/22
4	高温高湿储藏 High temperature and high humidity storage	Ta=60°C RH=90% 1000hrs	JEITA ED-4701 100 103	0/22
5	温度循环 Temperature cycling	-40°C~25°C~100°C~25°C 30min~5min~30min~5min 100 cycles	JEITA ED-4701 100 105	0/22
6	耐焊接热 Resistance to Soldering Heat	Tsld = 260°C, 10sec. 2 times	JEITA ED-4701 300 301	0/22
7	常温寿命测试 Normal temperature life test	25°C, IF: Typical current , 1000hrs	JESD22-A 108D	0/22

失效判定标准 Failure criteria:

项目 Project	符号 Symbol	测试条件 Test conditions	判断标准Judgment criteria	
			最小值 Minimum value	最大值 Maximum value
发光强度 Intensity	IV	DC=5V,规格典型电流 DC=5V, Typical current specification	初始数据X0.7 Initial data X0.7	---
耐焊接热 Resistance to Soldering Heat	---	DC=5V,规格典型电流 DC=5V, Typical current specification	无死灯或明显损坏 No dead lights or obvious damage	

