

客户图

NO.	ECN NO.	DESCRIPTION	DATE

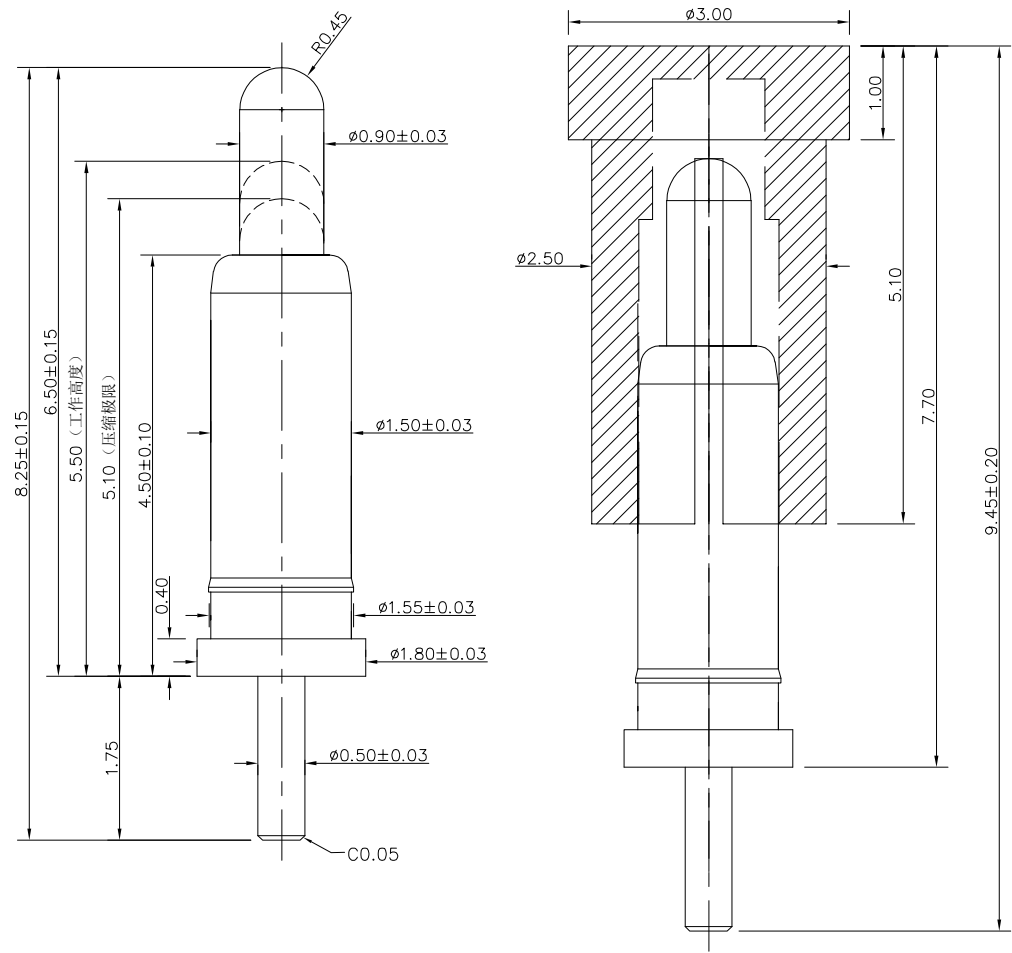

- Note:
- Material (材料):
 Barrel: Brass C3604 (针管: 黄铜 C3604)
 Plunger: Brass C3604 (针头: 黄铜 C3604)
 Spring: SUS304 (弹簧: SUS304)
 - Plating (电镀):
 Barrel: 5u' Au over 50~80u' Ni (针管: 镀金5u', 镍底50~80u'.)
 Plunger: 5u' Au over 50~80u' Ni (针头: 镀金5u', 镍底50~80u'.)
 Spring: Gold plated (弹簧: 镀金)
 - Electrical (电气特性):
 Rated Current & Voltage: DC 12V, 3A (额定电压&电流: 直流12V, 3A)
 Contact Resistance: 50 mohm Max. at working height.
 接触电阻: 最大50毫欧 (在工作高度状态下)
 - Mechanical (机械性能):
 Force: 20g ± 5g at working height. (20g ± 5g 在工作高度)
 Durability: 10,000 cycles (min) (寿命: 10000次)
 - Work Temperature (工作环境):
 Withstanding High Temperature: 280°C
 Operational Temperature: -40°C ~ +85°C

深圳市鑫探技术有限公司
 HTTP://WWW.XYZPOGOPIN.COM
 TEL: 0755-28773277 FAX: 0755-28891353



SCALE:	N/A	UNIT	mm
SHEET:	1 of 1	PROJECTION	
DATE:	2025.06.10	VER.	D.0

THE UNMARKED TOLERANCE ARE AS BELOW :			
LENGTH		ANGLE	
X.XX	±0.05mm	X.XX	±0.50°
X.X	±0.10mm	X.X	±1.00°
X.	±0.20mm	X.	±2.00°

DESIGNED BY:		DWG. NO.	YZ191515082P-02
CHECKED BY:		TITLE:	Pogo pin连接器
APPROVED BY:			