

客户图

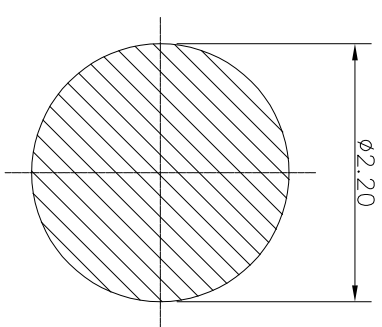
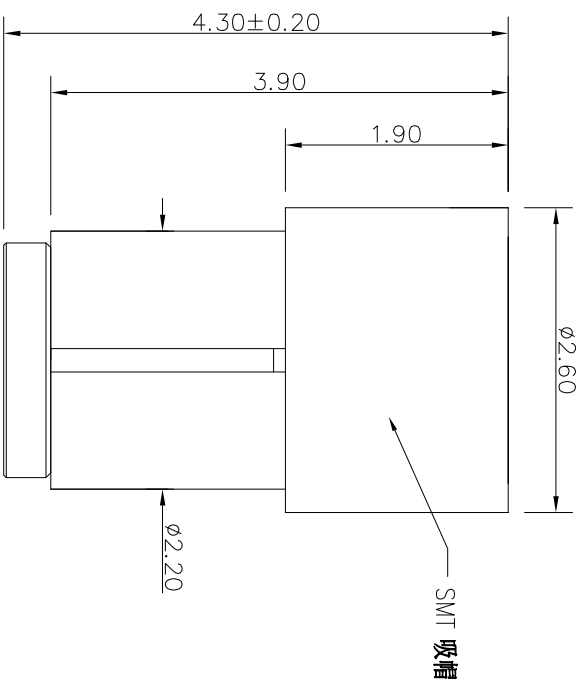
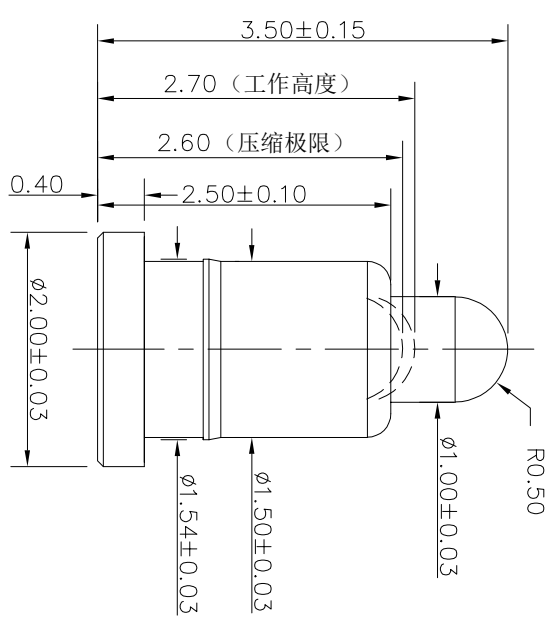

RECOMMENDED PCB LAYOUT

Note:

- 1: Material(材料) :
 Cap: PA46+30%GF (胶盖: PA46)
 Barrel: Brass C3604 (针管: 黄铜 C3604)
 Plunger: Brass C3604 (针头: 黄铜 C3604)
 Spring: SUS304 (弹簧: SUS304)
 Plating(电镀) :
 Barrel: 3u' Au over 50~80u' Ni(针管: 镀金3u', 镍底50~80u'.)
 Plunger: 3u' Au over 50~80u' Ni (针头: 镀金3u', 镍底50~80u'.)
 Spring: Gold flash (弹簧: 镀金)
 Rated Current & Voltage: DC 12V;1A (额定电压&电流: 直流12V,1A)
 Contact Resistance: 50 mohm Max. at working height.
 接触电阻: 最大50毫欧 (在工作高度状态下)
- 4: Mechanical(机械性能) :
 Force: 120g±20% at working height. (120g±20% 在工作高度)
 Durability: 10,000 cycles(min) (寿命: 10000次)
- 5: WorkTemperature(工作环境):
 Withstanding Higt Temperature: 280°C
 Operational Temperature: -20°C~ +70°C

NO.	ECN NO.	DESCRIPTION	DATE

深圳市鑫探技术有限公司

HTTP://WWW.XYZPOGOPIN.COM
TEL:0755-28773277 FAX:0755-28891353

SCALE:	N/A	UNIT	mm
SHEET:	1 of 1	PROJECTION	A.0
DATE:	2026.04.11	VER.	A.0

THE UNMARKED TOLERANCE ARE AS BELOW :

LENGTH	ANGLE
XXX ±0.05mm	XXX ±0.50°
XX ±0.10mm	XX ±1.00°
X ±0.20mm	X ±2.00°

DESIGNED BY:	DWG. NO.
CHECKED BY:	YZ00315035R-05
APPROVED BY:	成品图

TITLE:	成品图
--------	-----