

客户图

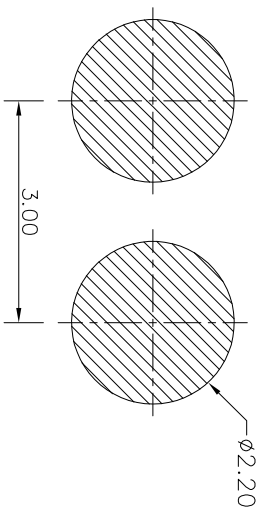
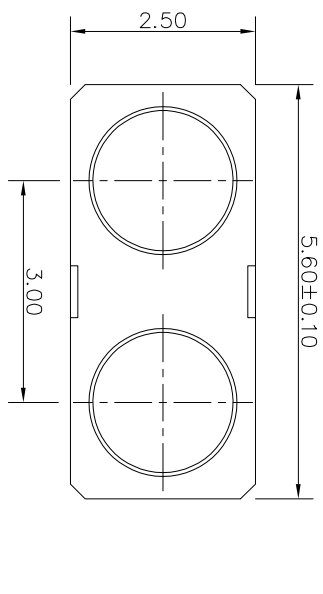
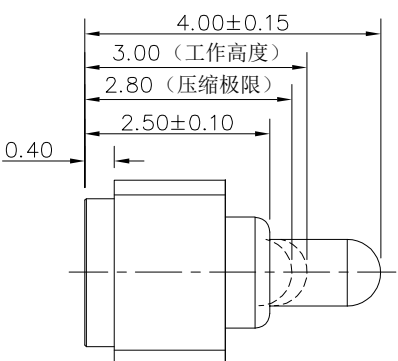
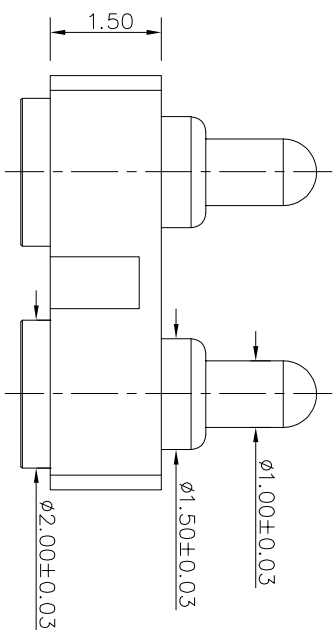

RECOMMENDED PCB LAYOUT

NO.	ECN NO.	DESCRIPTION	DATE

Note:

- 1: Material (材料) :
Housing: PA46+30%GF (胶芯: PA46)
Barrel: Brass C3604 (针管: 黄铜 C3604)
Plunger: Brass C3604 (针头: 黄铜 C3604)
Spring: SUS304 (弹簧: SUS304)
- 2: Plating (电镀) :
Barrel: 3u' Au over 50~80u' Ni (针管: 镀金3u', 镍底50~80u'.)
Plunger: 3u' Au over 50~80u' Ni (针头: 镀金3u', 镍底50~80u'.)
Spring: Gold plated (弹簧: 镀金)
- 3: Electrical (电气特性) :
Rated Current & Voltage: DC 12V, 1A (额定电压&电流: 直流12V, 1A)
Contact Resistance: 50 mohm Max. at working height.
接触电阻: 最大50毫欧 (在工作高度状态下)
Insulation Resistance: 1,000MΩ minimum. (绝缘电阻: 1,000MΩ 以上)
Dielectric Withstand Voltage: 500VAC/minute. (抗击电压: 500VAC/minute)
- 4: Mechanical (机械性能) :
Force: 150g±20% at working height. (150g±20% 在工作高度)。
Durability: 10,000 cycles(min) (寿命: 10000次)
- 5: WorkTemperature(工作环境) :
Withstanding Higt Temperature: 280°C
Operational Temperature: -20°C~ +70°C

深圳市鑫探技术有限公司

HTTP://WWW.XYZPOGOPIN.COM
TEL: 0755-28773277 FAX: 0755-28891353

SCALE:	N/A	UNIT:	mm
SHEET:	1 of 1	PROJECTION:	1st Angle
DATE:	2026.04.11	VER.	A.0

THE UNMARKED TOLERANCE ARE AS BELOW :

LENGTH	ANGLE
XXX ±0.05mm	X.XX ±0.50°
XX ±0.10mm	XX ±1.00°
X ±0.20mm	X ±2.00°

DESIGNED BY:	DWG. NO. YZ13215040R-02030-01
CHECKED BY:	
APPROVED BY:	

TITLE: Pogo pin 连接器