

客户图

NO.	ECN NO.	DESCRIPTION	DATE
-----	---------	-------------	------

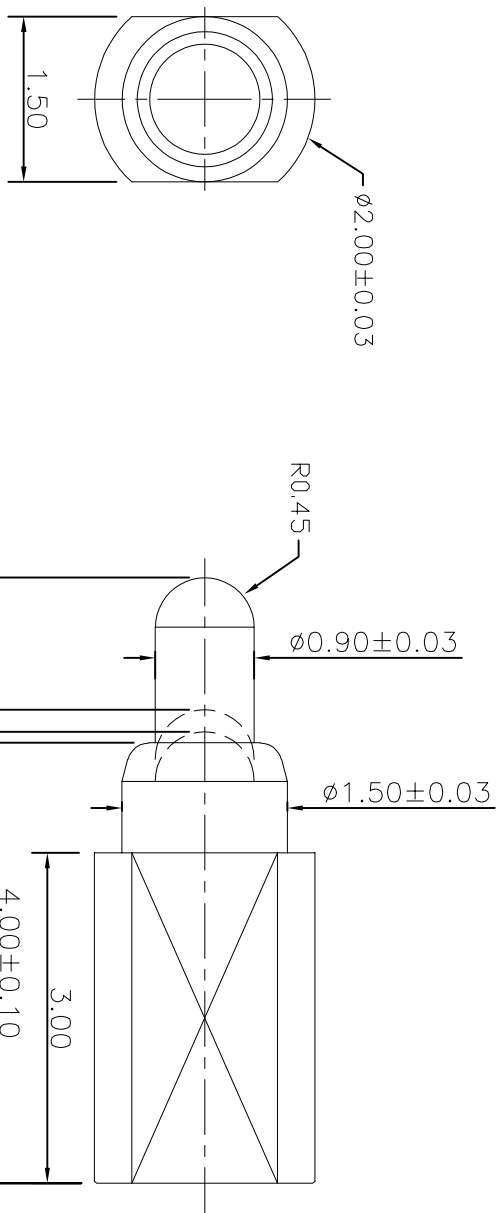

Note:

- 1: Material(材料) :
 Barrel: Brass C3604 (针管: 黄铜 C3604)
 Plunger: Brass C3604 (针头: 黄铜 C3604)
 Spring: SUS304 (弹簧: SUS304)
- 2: Plating(电镀) :
 Barrel: 3u' Au over 50~80u' Ni(针管: 镀金3u', 镍底50~80u'.)
 Plunger: 3u' Au over 50~80u' Ni (针头: 镀金3u', 镍底50~80u'.)
 Spring: No plated (弹簧: 不电镀)
- 3: Electrical(电气特性) :
 Rated Current & Voltage: DC 12V,2A (额定电压&电流: 直流12V,2A)
 Contact Resistance: 50 mohm Max. at working height.
 接触电阻: 最大50毫欧 (在工作高度状态下)
- 4: Mechanical(机械性能) :
 Force: 120g±20% at working height. (120g±20% 在工作高度)。
 Durability: 10,000 cycles(min) (寿命: 10000次)
- 5: WorkTemperature(工作环境):
 Withstanding Higt Temperature: 280°
 Operational Temperature: -20°~ +70°

深圳市鑫探技术有限公司

HTTP://WWW.XYZP0G0PIN.COM
 TEL:0755-28773277 FAX:0755-28891353



SCALE:	N/A	UNIT	mm	THE UNMARKED TOLERANCE ARE AS BELOW :	DESIGNED BY:	DWG. NO.	YZ102915055F-01
SHEET:	1 of 1	PROJECTION	1st Angle	LENGTH	CHECKED BY:	TITLE:	Pogo pin连接器
DATE:	2026.04.11	VER.	D.0	ANGLE	APPROVED BY:		
				±0.05mm			
				±0.10mm			
				±0.20mm			
				±0.50°			
				±1.00°			
				±2.00°			