

客户图

NO.	ECN NO.	DESCRIPTION	DATE
-----	---------	-------------	------

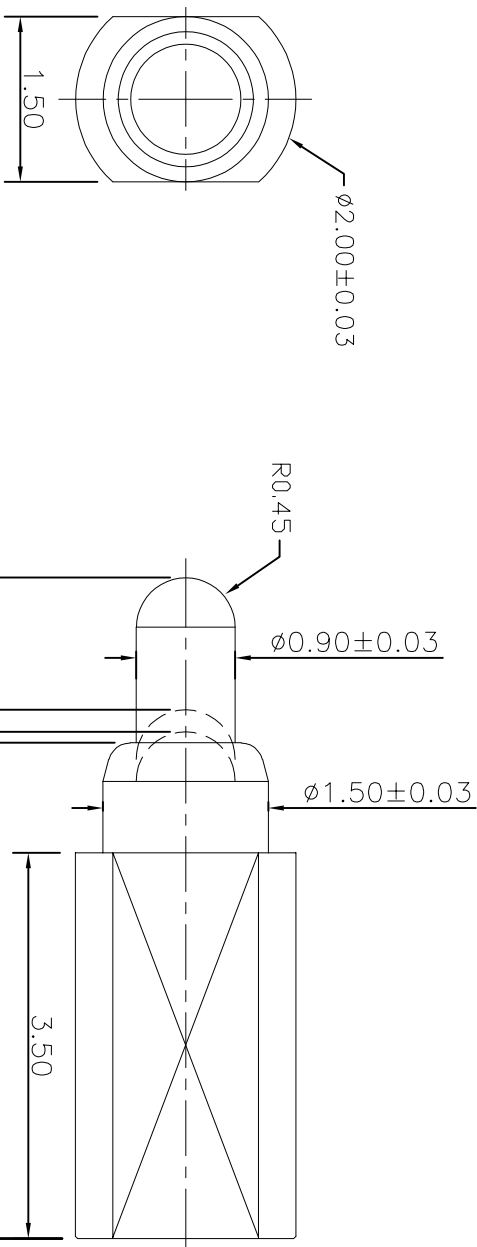

Note:

- 1: Material(材料) :
Barrel: Brass C3604 (针管: 黄铜 C3604)
Plunger: Brass C3604 (针头: 黄铜 C3604)
Spring: SUS304 (弹簧: SUS304)
- 2: Plating(电镀) :
Barrel: 3u' Au over 50~80u' Ni(针管: 镀金3u', 镍底50~80u'.)
Plunger: 3u' Au over 50~80u' Ni (针头: 镀金3u', 镍底50~80u'.)
Spring: No plated (弹簧: 不电镀)
- 3: Electrical(电气特性) :
Rated Current & Voltage: DC 12V;2A (额定电压&电流: 直流12V,2A)
Contact Resistance: 50 mohm Max. at working height.
接触电阻: 最大50毫欧 (在工作高度状态下)
- 4: Mechanical(机械性能) :
Force: 30g \pm 20% at working height. (30g \pm 20% 在工作高度)。
Durability: 10,000 cycles(min) (寿命: 10000次)
- 5: WorkTemperature(工作环境):
Withstanding Higt Temperature: 280 $^{\circ}$
Operational Temperature: -20 $^{\circ}$ ~ +70 $^{\circ}$

深圳市鑫探技术有限公司

HTTP://WWW.XYZP90GPPIN.COM
TEL:0755-28773277 FAX:0755-28891353



SCALE:	N/A	UNIT	mm
SHEET:	1 of 1	PROJECTION	
DATE:	2026.04.11	VER.	A.0

THE UNMARKED TOLERANCE ARE AS BELOW :

LENGTH	ANGLE
XXX X.X	X.XX X.X
± 0.05 mm ± 0.10 mm ± 0.20 mm	$\pm 0.50^{\circ}$ $\pm 1.00^{\circ}$ $\pm 2.00^{\circ}$

DESIGNED BY:	DWG. NO.	YZ00715060F-03
CHECKED BY:	TITLE:	Pogo pin连接器
APPROVED BY:		