

## PRODUCT SPECIFICATION

P/N: MEASJ105CB5226MF1A01

Type: Multilayer Ceramic Capacitors  
(High dielectric type)

Soldering: Reflow only

Issue date: March 7, 2023

Applicable products to RoHS restriction

**Part number list**

New part number	Former part number
MEASJ105CB5226MF1A01	JDK105CBJ226MV-F

Document No. MLRME220E01720T	Specifications Multilayer Ceramic Capacitor [High dielectric type]
---------------------------------	--

Please check and comply with the usage conditions and precautions described in this specification.  
Before use, please be sure to verify and validate our products under intended operating environmental conditions with the products being installed in actual devices.

1. Scope

This specification shall apply to multilayer chip type ceramic capacitors for reflow soldering (Pb-Free) used for Mobile devices electronic equipment.

For the details of such equipment, please refer to basic information and others in Section 6 in this specification.

2. Part Numbering System

Part number is indicated as follows:

(Ex.)   M     E     A     S     J     10     5     C     B5     226     M     F     1A01    
           ①    ②    ③    ④    ⑤    ⑥    ⑦    ⑧    ⑨    ⑩    ⑪    ⑫    ⑬

① Group

Code	
M	Multilayer Ceramic Capacitor

② Category

Code	Recommended equipment
E	Mobile Devices

③ Type

Code	
A	2 terminals

④ Features, Characteristics

Code	
S	Standard/General (reflow)

⑤ Rated Voltage

Code	[VDC]
J	6.3

⑥ Dimension

Code	JIS(mm)	EIA(inch)	L×W [mm]
10	1005	0402	1.0×0.5

⑦ Thickness

Code	[mm]
5	0.5

⑧ Dimension Tolerance

Code	
C	See Table 1.

⑨ Temperature Characteristics

Code	Applicable standard		Capacitance change rate [%]	Temperature range [°C]	Reference temperature [°C]
B5	EIA	X5R	±15	-55 to +85	25

⑩ Nominal Capacitance

Code	
226	See Table 2.

⑪ Capacitance Tolerance

Code	
M	±20%

⑫ Packaging

Code	
F	Taping

⑬ Internal Code

### 3. Shape, Structure, and Dimension

Figure 1: Shape and structure

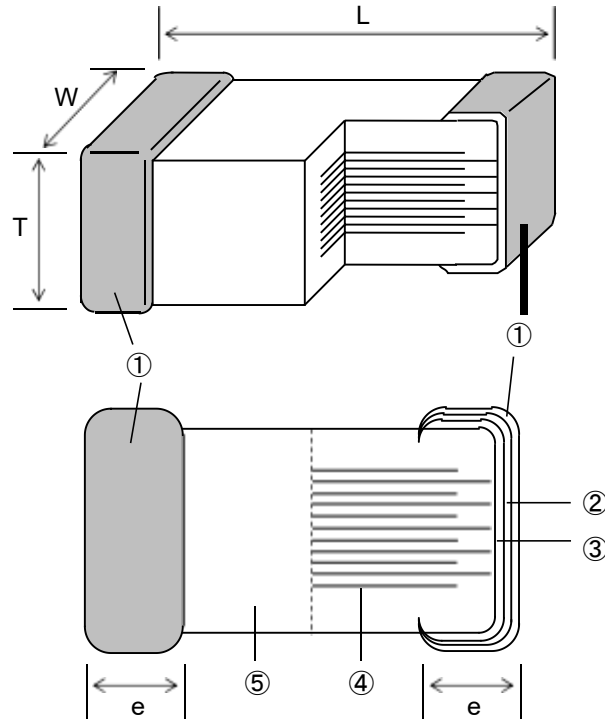

No.	Name	Material
①	Terminal Electrodes (Surface)	Sn Plating
②	Terminal Electrodes	Ni Plating
		Cu Plating
③	External Electrodes	Ni
④	Internal Electrodes	Ni
⑤	Dielectric	Barium titanate

Table 1: Dimensions

Code		Dimension [mm]			
Dimension	Tolerance	L	W	T	e
10	C	1.0+0.20/-0	0.5+0.20/-0	See Table 2.	0.25±0.10

4. Rated Value/Part Number List

Table 2: Part Number List

Operating temperature range: -55 to +85°C

Part number	Rated voltage (VDC)	Temp. char.	Capacitance (μF)	IR (MΩ . μF min.)	DF (% max.)	Measuring conditions Upper : Cap., DF Lower : T/C	Thickness (mm)
MEASJ105CB5226MF1A01	6.3	X5R	22.0	20	20.0	120Hz-0.5Vrms 120Hz-0.2Vrms	0.5+0.20/-0

## 5. Functions and Test Methods

### Test Conditions:

Standard test conditions shall be temperature of 5 to 35°C, relative humidity of 45 to 85%, and air pressure of 86 to 106 kPa. Tests shall be conducted at temperature of 25 ± 3°C, relative humidity of 60 to 70% and air pressure of 86 to 106 kPa if test results are suspicious. Unless otherwise specified, all tests shall be conducted under the standard test conditions.

No.	Item	Specified Value	Remarks				
1	Operating Temperature Range	Capable of continuous operation within the range.	-55 to +85°C				
2	Shape and Dimensions	See Fig 1 and Table 1.					
3	Heat Treatment		Initial value shall be measured after test sample is heat-treated at 150 +0/- 10°C for an hour and kept at room temperature for 24 ± 2 hours.				
4	Voltage Treatment		Initial value shall be measured after test sample is voltage-treated for an hour at temperature and voltage which are specified as test conditions, and kept at room temperature for 24 ± 2 hours.				
5	Dielectric Withstanding Voltage (between terminals)	No dielectric breakdown or damage	Conforming to EIA RS-198 (1991). 160% of DC rated voltage shall be applied for 1 to 5 seconds. Charging and discharging current shall be 50 mA or less.				
6	Insulation Resistance (IR)	See Table 2.	Conforming to EIA RS-198 (1991). Rated voltage shall be applied to test sample for 1 minute ± 5 seconds. Charging and discharging current shall be 50 mA or less.				
7	Capacitance (Cap.)	See Table 2.	Conforming to EIA RS-198 (1991). Heat treatment specified in this specification shall be conducted prior to measurement. Measuring frequency and voltage shall conform to the table below. <table border="1" data-bbox="820 1532 1410 1599"> <thead> <tr> <th>Measuring frequency</th> <th>Measuring voltage</th> </tr> </thead> <tbody> <tr> <td>120Hz±10Hz</td> <td>0.5±0.1Vrms</td> </tr> </tbody> </table>	Measuring frequency	Measuring voltage	120Hz±10Hz	0.5±0.1Vrms
Measuring frequency	Measuring voltage						
120Hz±10Hz	0.5±0.1Vrms						
8	Dissipation Factor (DF)	See Table 2.	Conforming to EIA RS-198 (1991). Heat treatment specified in this specification shall be conducted prior to measurement. Measuring frequency and voltage shall conform to the table below. <table border="1" data-bbox="820 1823 1410 1890"> <thead> <tr> <th>Measuring frequency</th> <th>Measuring voltage</th> </tr> </thead> <tbody> <tr> <td>120Hz±10Hz</td> <td>0.5±0.1Vrms</td> </tr> </tbody> </table>	Measuring frequency	Measuring voltage	120Hz±10Hz	0.5±0.1Vrms
Measuring frequency	Measuring voltage						
120Hz±10Hz	0.5±0.1Vrms						

No.	Item	Specified Value	Remarks				
9	Temperature Characteristic (T/C)	See P. 1 for ⑨.	<p>Heat treatment specified in this specification shall be conducted prior to measurement.</p> <p>Maximum capacitance deviation in both (+) and (-) sides in the range from lowest temperature to highest temperature for capacitor shall be indicated in ratio of variation in reference to capacitance value at reference temperature.</p> <p>Measuring frequency and voltage shall conform to the table below.</p> <table border="1" data-bbox="820 566 1393 633"> <thead> <tr> <th data-bbox="820 566 1106 600">Measuring frequency</th> <th data-bbox="1106 566 1393 600">Measuring voltage</th> </tr> </thead> <tbody> <tr> <td data-bbox="820 600 1106 633">120Hz±10Hz</td> <td data-bbox="1106 600 1393 633">0.2±0.05Vrms</td> </tr> </tbody> </table>	Measuring frequency	Measuring voltage	120Hz±10Hz	0.2±0.05Vrms
Measuring frequency	Measuring voltage						
120Hz±10Hz	0.2±0.05Vrms						
10	Adhesive Force of Terminal Electrodes	Terminal electrodes shall be no exfoliation or a sign of exfoliation.	Test sample shall be soldered to test board shown in Fig. 2, and a force of 5N (0.51 kgf) shall be applied for 30 ± 5 seconds.				
11	Vibration	Initial performance shall be satisfied.	<p>Conforming to EIA RS-198 (1991).</p> <p>Test sample shall be soldered to board shown in Fig. 2. Heat treatment specified in this specification shall be conducted prior to test.</p> <p>Test conditions:  Frequency range: 10-55 Hz  Overall amplitude: 1.5 mm  Sweeping method: 10-55-10 Hz for 1 minute  Two hours each in X, Y, Z directions: 6 hours in total</p>				

No.	Item	Specified Value	Remarks																
12	Solderability	More than 95% of terminal electrodes shall be covered with fresh solder.	<p><b>【Eutectic】</b> Solder used shall be [JIS Z 3282 H60A or H63A]. Test sample shall be completely submerged in molten solder at <math>230 \pm 5^{\circ}\text{C}</math> for <math>4 \pm 1</math> seconds.</p>																
			<p><b>【Pb free】</b> Solder used shall be [Sn/3.0Ag/0.5Cu]. Test sample shall be completely submerged in molten solder at <math>245 \pm 3^{\circ}\text{C}</math> for <math>4 \pm 1</math> seconds.</p>																
13	Resistance to Soldering Heat	Appearance	No abnormality	<p>Conforming to EIA RS-198 (1991). Heat treatment specified in this specification shall be conducted prior to test. Test sample shall be completely submerged in molten solder of <math>270 \pm 5^{\circ}\text{C}</math> for <math>3 \pm 0.5</math> seconds. Preheating as shown in the table below shall be continuously conducted before submersion, and test sample shall be kept at room temperature after test.</p>															
		Cap. Change	See Table 3.																
		DF	See Table 3.																
		IR	Initial value shall be satisfied.																
		Dielectric Withstanding Voltage (between terminals)	No dielectric breakdown or damage	<table border="1"> <thead> <tr> <th>Sequence</th> <th>Temperature (<math>^{\circ}\text{C}</math>)</th> <th>Time (min.)</th> </tr> </thead> <tbody> <tr> <td>1</td> <td>80 to 100</td> <td>2 to 5</td> </tr> <tr> <td>2</td> <td>150 to 200</td> <td>2 to 5</td> </tr> </tbody> </table>	Sequence	Temperature ( $^{\circ}\text{C}$ )	Time (min.)	1	80 to 100	2 to 5	2	150 to 200	2 to 5						
		Sequence	Temperature ( $^{\circ}\text{C}$ )	Time (min.)															
1	80 to 100	2 to 5																	
2	150 to 200	2 to 5																	
			Measurement shall be conducted after test sample is kept at room temperature for $24 \pm 2$ hours.																
14	Thermal Shock	Appearance	No abnormality	<p>Conforming to EIA RS-198 (1991). Test sample shall be soldered to board shown in Fig. 2. Heat treatment specified in this specification shall be conducted prior to test. Test sample shall be exposed to each of temperature conditions in the following steps 1 to 4 in sequence for the specified time.</p>															
		Cap. Change	See Table 3.																
		DF	See Table 3.																
		IR	Initial value shall be satisfied.																
		Dielectric Withstanding Voltage (between terminals)	No dielectric breakdown or damage	<table border="1"> <thead> <tr> <th>Step</th> <th>Temperature (<math>^{\circ}\text{C}</math>)</th> <th>Time (min.)</th> </tr> </thead> <tbody> <tr> <td>1</td> <td>Lowest operating temperature</td> <td><math>30 \pm 3</math></td> </tr> <tr> <td>2</td> <td>Ambient temperature</td> <td>2 to 3</td> </tr> <tr> <td>3</td> <td>Highest operating temperature</td> <td><math>30 \pm 3</math></td> </tr> <tr> <td>4</td> <td>Ambient temperature</td> <td>2 to 3</td> </tr> </tbody> </table>	Step	Temperature ( $^{\circ}\text{C}$ )	Time (min.)	1	Lowest operating temperature	$30 \pm 3$	2	Ambient temperature	2 to 3	3	Highest operating temperature	$30 \pm 3$	4	Ambient temperature	2 to 3
		Step	Temperature ( $^{\circ}\text{C}$ )	Time (min.)															
1	Lowest operating temperature	$30 \pm 3$																	
2	Ambient temperature	2 to 3																	
3	Highest operating temperature	$30 \pm 3$																	
4	Ambient temperature	2 to 3																	
			Temperature cycle shall be repeated five (5) times by this method, and measurement shall be conducted after test sample is kept at room temperature for $24 \pm 2$ hours.																

No.	Item	Specified Value	Remarks	
15	Humidity (Steady State)	Appearance	No abnormality	<p>Conforming to EIA RS-198 (1991). Heat treatment specified in this specification shall be conducted prior to test. Test sample shall be put into constant temperature/humidity bath at <math>40 \pm 2^{\circ}\text{C}</math> and 90 to 95%RH for 500 +24/-0 hours. Measurement shall be conducted after test sample is kept at room temperature for <math>24 \pm 2</math> hours.</p>
		Cap. Change	See Table 3.	
		DF	See Table 3.	
		IR	See Table 3.	
16	High Temperature Loading	Appearance	No abnormality	<p>Conforming to EIA RS-198 (1991). Voltage treatment specified in this specification shall be conducted prior to test. Test sample shall be put in thermostatic oven at maximum operating temperature, and specified DC voltage shall be continuously applied for 1000 +48/-0 hours. (Applied DC voltage is described in Table 3.) Charging and discharging current shall be 50 mA or less. Measurement shall be conducted after test sample is kept at room temperature for <math>24 \pm 2</math> hours.</p>
		Cap. Change	See Table 3.	
		DF	See Table 3.	
		IR	See Table 3.	
17	Humidity Loading	Appearance	No abnormality	<p>Conforming to EIA RS-198 (1991). Voltage treatment specified in this specification shall be conducted prior to test. Test sample shall be put into constant temperature/humidity bath at <math>40 \pm 2^{\circ}\text{C}</math> and 90 to 95%RH, and DC rated voltage shall be continuously applied for 500 +24/-0 hours. Charging and discharging current shall be 50mA or less. Measurement shall be conducted after test sample is kept at room temperature for <math>24 \pm 2</math> hours.</p>
		Cap. Change	See Table 3.	
		DF	See Table 3.	
		IR	See Table 3.	
18	Bending Strength	Appearance	No abnormality	<p>Test sample shall be soldered to test board as shown in Fig. 3. Sample shall be carefully soldered to avoid abnormality such as heat shock. The board is bent 1.0 mm for 10 seconds as shown in Fig. 4. Measurement shall be conducted as the board is bent 1.0 mm.</p>
		Cap. Change	$\pm 12.5\%$	

Table 3: Cap., DF, and IR Changes after Test

Part Number	Resistance to Soldering Heat		Thermal Shock		Humidity (Steady state)			High Temperature Loading				Humidity Loading		
	Cap. chg. rate (%)	DF (% max.)	Cap. chg. rate (%)	DF (% max.)	Cap. chg. rate (%)	DF (% max.)	※1	Cap. chg. rate (%)	DF (% max.)	Applied voltage (%)	※1	Cap. chg. rate (%)	DF (% max.)	※1
MEASJ105CB5226MF1A01	±25.0	20.0	±40.0	20.0	±25.0	20.0	2	±25.0	20.0	100	2	±60.0	20.0	1

【Notes】 ※1: IR after test ( $M\Omega \cdot \mu F$  min.)

Fig. 2: Board of Adhesive Force of Terminal Electrodes, Vibration, and Thermal Shock Tests

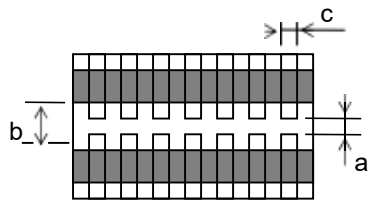

Size (L x W)	a	b	c
1.0×0.5	0.4	1.5	0.5

[Unit: mm]

Material: Glass epoxy board [JIS C 6484]

□ Copper foil (Thickness: 0.035mm)

■ Solder resist

Remarks: Uniform soldering shall be conducted by using soldering iron or soldering oven.  
Soldering shall be conducted with care to avoid abnormality such as heat shock.

Fig. 3: Board for Bending Strength Test

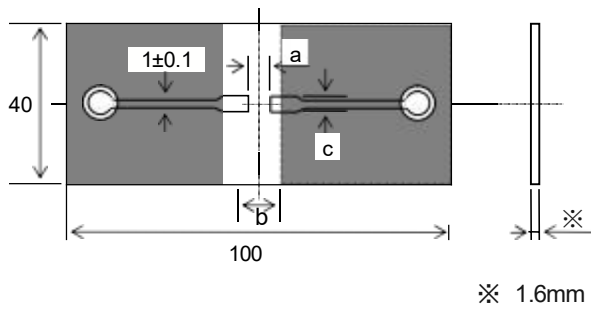

Material: Glass epoxy board [JIS C 6484]

□ Copper foil (Thickness: 0.035 mm)

■ Solder resist

Size (L x W)	a	b	c
1.0×0.5	0.4	1.5	0.5

[Unit: mm]

Fig. 4: Bending Strength Test Method

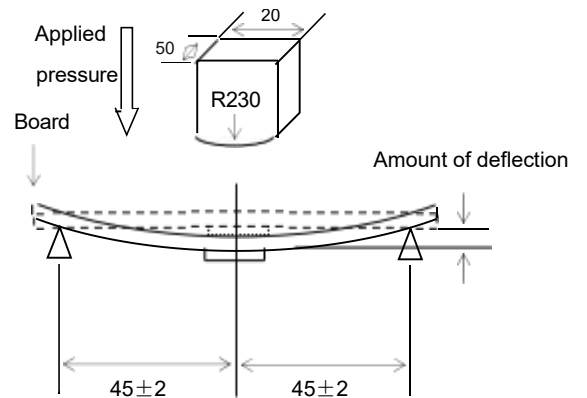

[Unit: mm]

Apply pressure at the rate of 0.5 mm/sec.  
until amount of deflection reaches 1.0 mm.

## 6. Basic Information and Others

### 6-1. Limited Application

#### 6-1-1. Equipment Intended for Use

The products listed in this specification are intended for general-purpose and standard use in general electronic equipment for consumer (e.g., AV equipment, OA equipment, home electric appliances, office equipment, information and communication equipment including, without limitation, mobile phone, and PC) and other equipment specified in the catalog or the product specification, or the equipment approved separately by TAIYO YUDEN.

TAIYO YUDEN has the product series intended for use in the following equipment. Therefore, when using our products for these equipment, please check available applications specified in the catalog or the product specification and use the corresponding products.

Application	Product Series		Quality Grade <sup>*3</sup>
	Equipment <sup>*1</sup>	Category (Part Number Code <sup>*2</sup> )	
Automotive	Automotive Electronic Equipment (POWERTRAIN, SAFETY)	A	1
	Automotive Electronic Equipment (BODY & CHASSIS, INFOTAINMENT)	C	2
Industrial	Telecommunications Infrastructure and Industrial Equipment	B	2
Medical	Medical Devices classified as GHTF Class C (Japan Class III)	M	2
	Medical Devices classified as GHTF Classes A or B (Japan Classes I or II)	L	3
Consumer	General Electronic Equipment	S	3
Mobile	Mobile Devices	E	4

- \*Notes:
1. Based on the general specifications required for electronic components for such equipment, which are recognized by TAIYO YUDEN, the use of each product series for the equipment is recommended. Please be sure to contact TAIYO YUDEN before using our products for equipment other than those covered by the product series.
  2. On each of our part number, the 2nd code from the left is a code indicating the "Category" as shown in the above table. For details, please check the explanatory materials regarding the part numbering system of each of our products.
  3. Each product series is assigned a "Quality Grade" from 1 to 4 in order of higher quality. Please do not incorporate a product into any equipment with a higher Quality Grade than the Quality Grade of such product without the prior written consent of TAIYO YUDEN.

#### 6-1-2. Equipment Requiring Inquiry

Please be sure to contact TAIYO YUDEN for further information before using the products listed in this specification for the following equipment (excluding intended equipment as specified in the catalog or the product specification) which may cause loss of human life, bodily injury, serious property damage and/or serious public impact due to a failure or defect of the products and/or malfunction attributed thereto.

- (1) Transportation equipment (automotive powertrain control system, train control system, and ship control system, etc.)
- (2) Traffic signal equipment
- (3) Disaster prevention equipment, crime prevention equipment
- (4) Medical devices classified as GHTF Class C (Japan Class III)
- (5) Highly public information network equipment, data-processing equipment (telephone exchange, and base station, etc.)
- (6) Any other equipment requiring high levels of quality and/or reliability equal to the equipment listed above

#### 6-1-3. Equipment Prohibited for Use

Please do not incorporate our products into the following equipment requiring extremely high levels of safety and/or reliability.

- (1) Aerospace equipment (artificial satellite, rocket, etc.)
- (2) Aviation equipment \*1
- (3) Medical devices classified as GHTF Class D (Japan Class IV), implantable medical devices \*2
- (4) Power generation control equipment (nuclear power, hydroelectric power, thermal power plant control system, etc.)
- (5) Undersea equipment (submarine repeating equipment, etc.)
- (6) Military equipment
- (7) Any other equipment requiring extremely high levels of safety and/or reliability equal to the equipment listed above

\*Notes: 1. There is a possibility that our products can be used only for aviation equipment that does not directly affect the safe operation of aircraft (e.g., in-flight entertainment, cabin light, electric seat, cooking equipment) if such use meets requirements specified separately by TAIYO YUDEN. Please be sure to contact TAIYO YUDEN for further information before using our products for such aviation equipment.

2. Implantable medical devices contain not only internal unit which is implanted in a body, but also external unit which is connected to the internal unit.

#### 6-1-4. Limitation of Liability

Please note that unless you obtain prior written consent of TAIYO YUDEN, TAIYO YUDEN shall not be in any way responsible for any damages incurred by you or third parties arising from use of the products listed in this specification for any equipment that is not intended for use by TAIYO YUDEN, or any equipment requiring inquiry to TAIYO YUDEN or prohibited for use by TAIYO YUDEN as described above.

#### 6-1-5. Safety Design

When using our products for high safety and/or reliability-required equipment or circuits, please fully perform safety and/or reliability evaluation. In addition, please install (i) systems equipped with a protection circuit and a protection device and/or (ii) systems equipped with a redundant circuit or other system to prevent an unsafe status in the event of a single fault for a failsafe design to ensure safety.

#### 6-1-6. Pre-Evaluation in the Actual Equipment and Conditions

Please conduct validation and verification of our products in actual conditions of mounting and operating environment before using our products.

#### 6-1-7. Intellectual Property Rights

Information contained in this specification is intended to convey examples of typical performances and/or applications of our products and is not intended to make any warranty with respect to the intellectual property rights or any other related rights of TAIYO YUDEN or any third parties nor grant any license under such rights.

#### 6-1-8. Limited Warranty

Please note that the scope of warranty for our products is limited to the delivered our products themselves conforming to the product specifications specified in the product specification, and TAIYO YUDEN shall not be in any way responsible for any damages resulting from a failure or defect in our products. Notwithstanding the foregoing, if there is a written agreement (e.g., supply and purchase agreement, quality assurance agreement) signed by TAIYO YUDEN and your company, TAIYO YUDEN will warrant our products in accordance with such agreement, provided, however, that our products shall be used for general-purpose and standard use in the equipment specified in this specification.

#### 6-1-9. TAIYO YUDEN's Official Sales Channel

The contents of this specification are applicable to our products which are purchased from our sales offices or authorized distributors (hereinafter "TAIYO YUDEN's official sales channel"). Please note that the contents of this specification are not applicable to our products purchased from any seller other than TAIYO YUDEN's official sales channel.

#### 6-1-10. Caution for Export

Some of our products listed in this specification may require specific procedures for export according to "U.S. Export Administration Regulations", "Foreign Exchange and Foreign Trade Control Law" of Japan, and other applicable regulations. Should you have any questions on this matter, please contact our sales staff.

#### 6-2. Manufacturing site

TAIYO YUDEN CO., LTD. (JAPAN)

TAIYO YUDEN (GUANG DONG) CO., LTD. (CHINA)

TAIYO YUDEN (SARAWAK) SDN. BHD (MALAYSIA)

#### 6-3. Precautions in Usage

- This specification does not cover the products when Sn-Zn lead free solder is used.
- When the products are used in places where dew condensation develops and/or where corrosive gas such as hydrogen sulfide, sulfurous acid, or chlorine exists in the air, insulation (dielectric) deterioration may occur.

Please do not use capacitors under such environmental conditions.

#### 6-4. Storage Conditions

- Temperature and humidity in storage area shall be controlled carefully to maintain the solderability of terminal electrodes and to keep the packaging material in good condition. Humidity should especially be kept as low as possible.

- Recommended conditions

Ambient temperature: 30°C or below

Humidity: 20 to 70% RH

The ambient temperature must be kept from 5 to 40°C. Even under ideal storage conditions, capacitor electrode solderability decreases with time. Therefore, ceramic chip capacitors should be used within six (6) months from the time of delivery. If the period is exceeded, please check solderability before using the capacitors.

- The packaging material should be kept where no chlorine or sulfur exists in the air.

#### 6-5. RoHS Compliance

- The products conform to RoHS.
- “RoHS compliance” means that the products do not contain lead, cadmium, mercury, hexavalent chromium, PBB, PBDE, DBP, DEHP, BBP, or DIBP referring to Directive (EU)2015/863, except other non-restricted substances or impurities which cannot be technically removed at refining process.
- The products are halogen-free products.

#### 6-6. Resin Coating:

- Coating/molding capacitors with resin may have negative effects on the functions of the products.
- When the products are coated/molded with resin, please check effects on the products by analyzing them in actual applications/devices before use.

## 7. Packaging

[Tape Packaging: 1005 Type (thickness code : 5)]

© Tape packaging type: Paper tape

Dimensions [Unit: mm] ※1

Type	A	B
1005	$0.65 \pm 0.1$	$1.15 \pm 0.1$
	$0.7 \pm 0.1$ ※2	$1.2 \pm 0.1$ ※2
	$0.74 \pm 0.08$ ※3	$1.34 \pm 0.08$ ※3
	$0.8 \pm 0.1$ ※4	$1.4 \pm 0.1$ ※4
	$0.88 \pm 0.08$ ※5	$1.5 \pm 0.08$ ※5

Dimensions [Unit: mm]

Type	C	D	E	F	G	H	J	t ※1
1005	$8.0 \pm 0.3$	$3.5 \pm 0.05$	$1.75 \pm 0.1$	$2.0 \pm 0.05$	$2.0 \pm 0.05$	$4.0 \pm 0.1$	$\phi 1.5$ $+0.1/-0$	0.8 max.
								0.85 max. ※4
								0.95 max. ※5

※ 1. A, B, t: Sufficient clearances are secured.

※ 2. MEAS\*105A\*\*\*\*\*

※ 3. MEAS\*105B\*\*\*\*\*

※ 4. MEAS\*105C\*\*\*\*\*

※ 5. MEAS\*105E\*\*\*\*\*

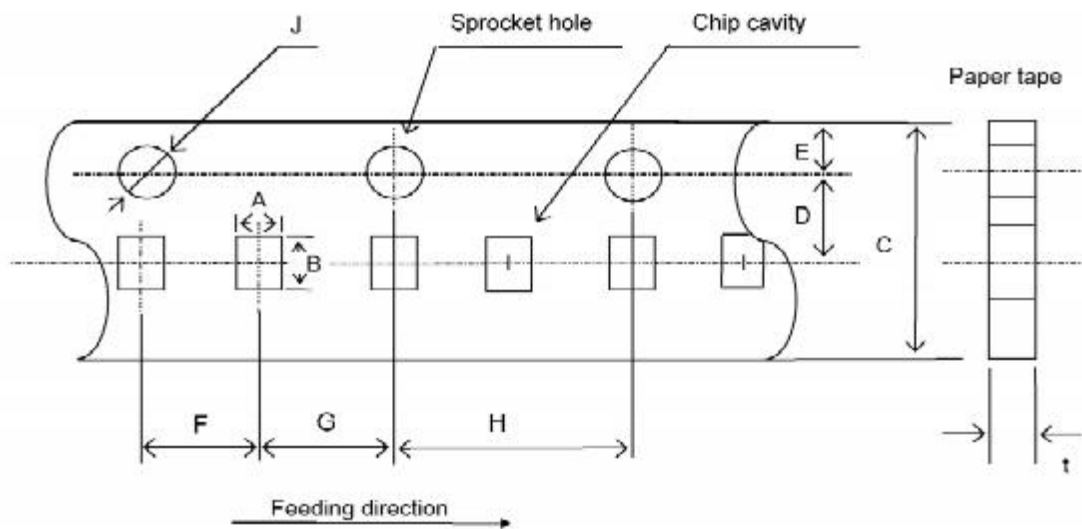

[Tape Packaging: 1005 Type]

Dimensions of Reel [Unit: mm]

Type	A	B	C	D	E	W	t	R
1005	$\phi 178 \pm 2.0$	$\phi 50 \text{ min.}$	$\phi 13.0 \pm 0.2$	$\phi 21.0 \pm 0.8$	$2.0 \pm 0.5$	$10.0 \pm 1.5$	$2.5 \text{ max.}$	1.0

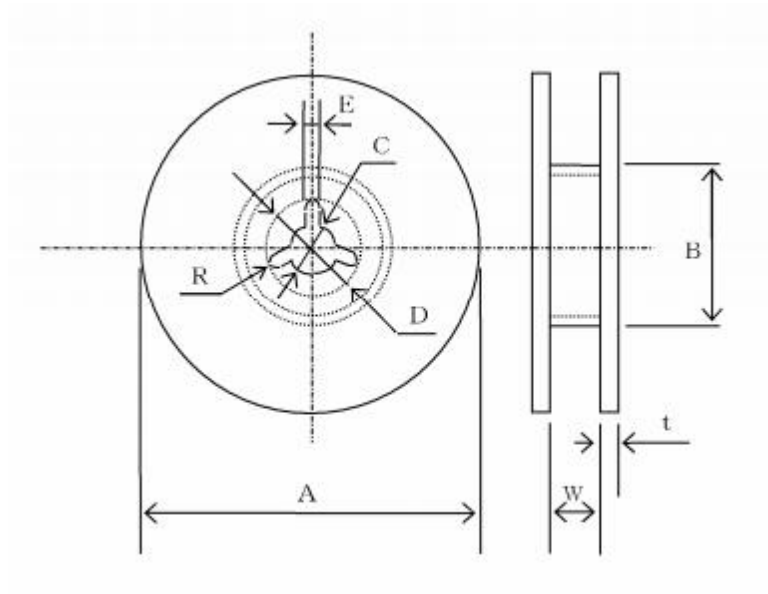

[Tape Packaging: 1005 Type (thickness code : 5)]

- 1) Taping shall be right-sided wound. Sprocket hole shall be on the right side against the pull-out direction.
- 2) Either the width side (W) or the thickness side (T) of the products below faces up at random when the products are inserted in the chip cavities.( thickness code 5)
- 3) There shall be blank spaces in each reel tape as shown in the following figure.
  - Leader part 400mm min.
  - Leader part (Blank part) 100mm min.
  - Trailer (Blank part) 160mm min.

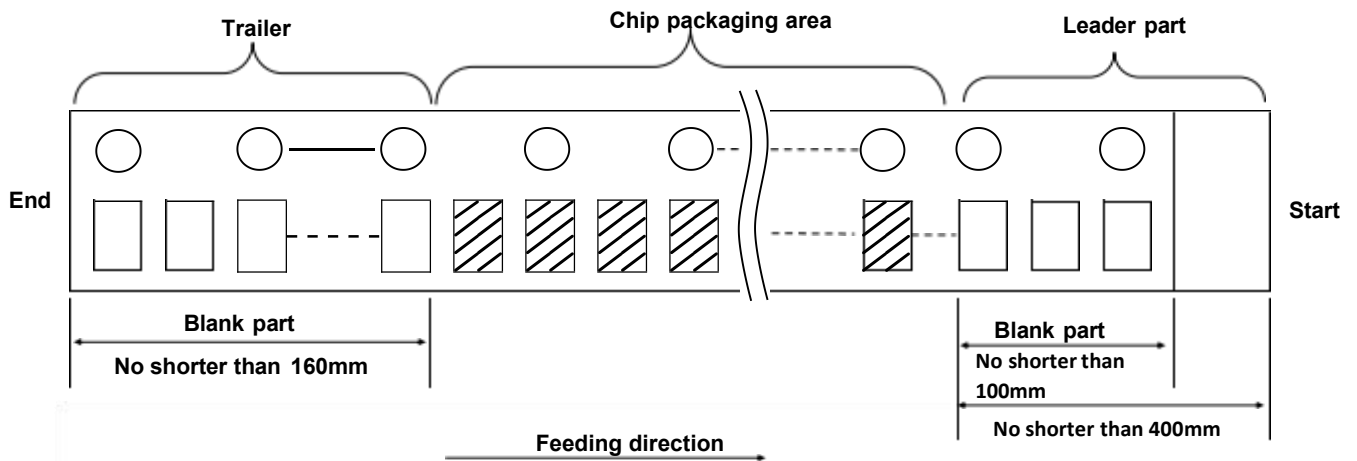

- 4) Top tape and bottom tape (only thickness rank 5) of paper taping shall not be crossed over sprocket holes.
- 5) Paper tape shall not be seamed.
- 6) Tensile strength of the tape is 5N (0.51kgf) or over.
- 7) The number of the chip missing from tape reel shall be one ( 1 ) piece at a maximum per reel.
- 8) The number of packaged chips per reel is shown in the table below.
- 9) Label indicating part No., quantity and control No. shall be attached to the outside of reel.
- 10) Peeling strength of top tape shall be 0.1 to 0.7N ( 10.2 to 71.4gf) when top tape is peeled from carrier tape at an angle of 0 to 20 degrees.



Quantity of taping package

Type	Thickness [Unit: mm] (Thickness code)	Quantity (pcs/reel)	Carrier tape
1005	0.5 (5)	10,000	Paper

[Packaging Mode]

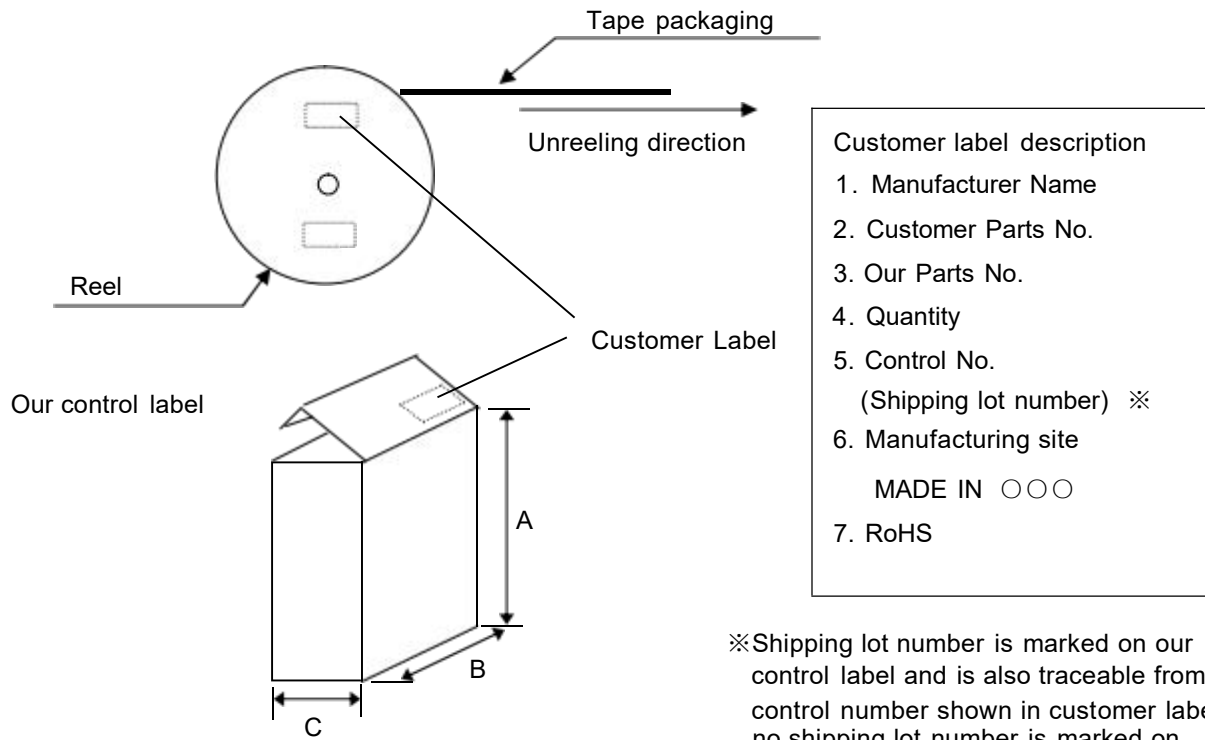

※Shipping lot number is marked on our control label and is also traceable from control number shown in customer label; no shipping lot number is marked on customer label.

【1005 size】

Code	A	B	C	No. of reels
Size	190	185	70	5 reels max.
			140	10 reels max.

Material: Paper [Unit: mm]

(The size is only for reference.)

Note:

Labels are attached on reels/boxes only after components passed all inspections.

Labeled products: Acceptance components

[Composition of shipping lot number]

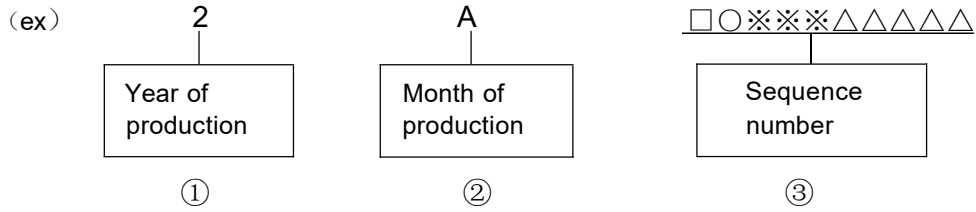

- ① Year of production (The last numeral of the Christian era. Year 2022→2)
- ② Month of production (See the table below.)
- ③ Sequence number is alphanumeric including space.

Month	1	2	3	4	5	6	7	8	9	10	11	12
Code	A	B	C	D	E	F	G	H	J	K	L	M

## Recommended Soldering Profiles for Lead-free Solder Paste

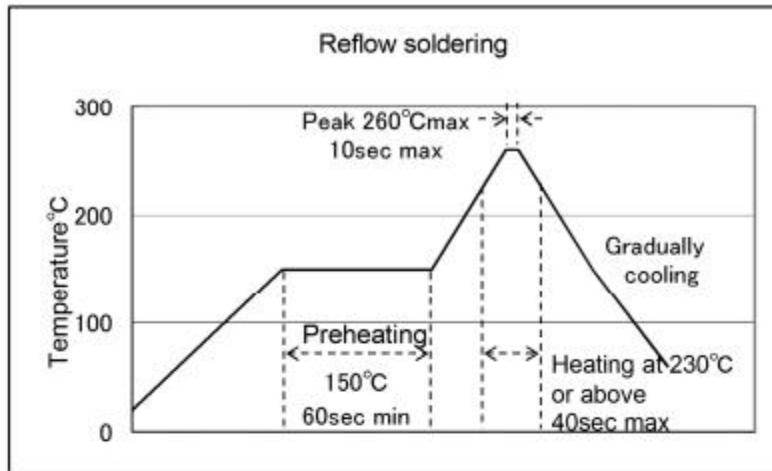

\*Ceramic chip component should be preheated sufficiently to maintain the temperature difference between the component surface and solder at 130°C or below.

\*Allowable number of reflow soldering: **2 times max.**

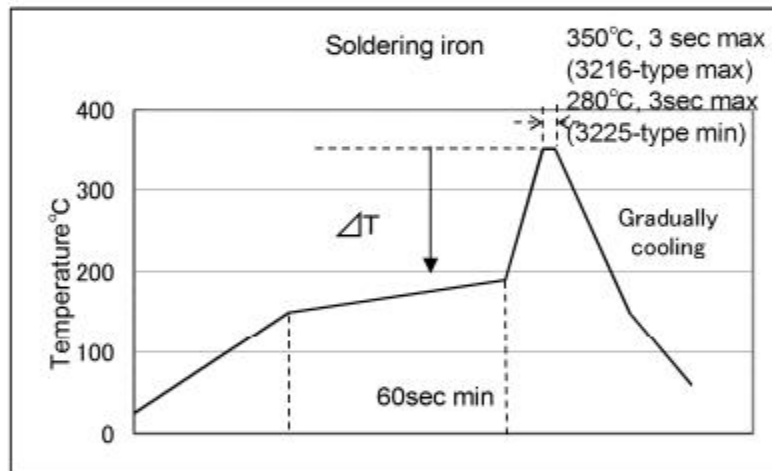

\*  $\Delta T \leq 150^\circ\text{C}$  (3216-type max),  $\Delta T \leq 130^\circ\text{C}$  (3225-type min)

\*Preheating control: Boards and components should be preheated sufficiently at 150°C or over, and soldering should be conducted with soldering iron as boards and components are maintained at sufficient temperatures.

\*The soldering iron should not directly touch the components.

\*Allowable number of hand soldering: **1 time max.**

\*Recommendation: Use 20W-soldering iron with the 1φ-tip or less.

Temperature in usage of Pb-free solder (Sn-3Ag-0.5Cu)

Case size	Soldering iron tip temp	Preheating temp.
3216-type max.	$\leq 350^\circ\text{C}$	$\geq 150^\circ\text{C}$
3225-type min.	$\leq 280^\circ\text{C}$	$\geq 150^\circ\text{C}$

\*\*Note: The above profiles are the maximum allowable soldering condition; therefore, these profiles are not always recommended.

# PRECAUTIONS

1. Circuit Design	
Precautions	<p>◆Verification of operating environment, electrical rating and performance</p> <p>1. A malfunction of equipment in fields such as medical, aerospace, nuclear control, etc. may cause serious harm to human life or have severe social ramifications. Therefore, any capacitors to be used in such equipment may require higher safety and reliability, and shall be clearly differentiated from them used in general purpose applications.</p> <p>◆Operating Voltage (Verification of Rated voltage)</p> <p>1. The operating voltage for capacitors must always be their rated voltage or less. If an AC voltage is loaded on a DC voltage, the sum of the two peak voltages shall be the rated voltage or less. For a circuit where an AC or a pulse voltage may be used, the sum of their peak voltages shall also be the rated voltage or less.</p> <p>2. Even if an applied voltage is the rated voltage or less reliability of capacitors may be deteriorated in case that either a high frequency AC voltage or a pulse voltage having rapid rise time is used in a circuit.</p>

2. PCB Design	
Precautions	<p>◆Pattern configurations (Design of Land-patterns)</p> <p>1. When capacitors are mounted on PCBs, the amount of solder used (size of fillet) can directly affect the capacitor performance. Therefore, the following items must be carefully considered in the design of land patterns:</p> <p>(1) Excessive solder applied can cause mechanical stresses which lead to chip breaking or cracking. Therefore, please consider appropriate land-patterns for proper amount of solder.</p> <p>(2) When more than one component are jointly soldered onto the same land, each component's soldering point shall be separated by solder-resist.</p> <p>◆Pattern configurations (Capacitor layout on PCBs)</p> <p>After capacitors are mounted on boards, they can be subjected to mechanical stresses in subsequent manufacturing processes (PCB cutting, board inspection, mounting of additional parts, assembly into the chassis, wave soldering of the boards, etc.). For this reason, land pattern configurations and positions of capacitors shall be carefully considered to minimize stresses.</p>

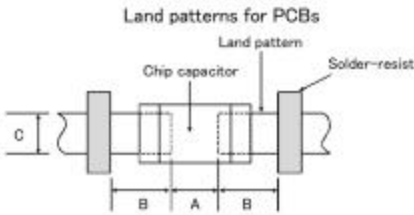
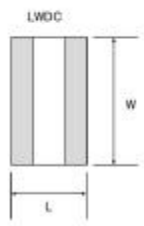
Technical considerations																																																																																																																
	<p>◆Pattern configurations (Design of Land-patterns)</p> <p>The following diagrams and tables show some examples of recommended land patterns to prevent excessive solder amounts.</p> <p>(1) Recommended land dimensions for typical chip capacitors</p> <p>●Multilayer Ceramic Capacitors : Recommended land dimensions (unit: mm)</p> <p>Wave-soldering</p> <table border="1"> <thead> <tr> <th>Type</th> <th>1608</th> <th>2012</th> <th>3216</th> <th>3225</th> </tr> </thead> <tbody> <tr> <td rowspan="2">Size</td> <td>L</td> <td>1.6</td> <td>2.0</td> <td>3.2</td> </tr> <tr> <td>W</td> <td>0.8</td> <td>1.25</td> <td>1.6</td> </tr> <tr> <td>A</td> <td>0.8 to 1.0</td> <td>1.0 to 1.4</td> <td>1.8 to 2.5</td> <td>1.8 to 2.5</td> </tr> <tr> <td>B</td> <td>0.5 to 0.8</td> <td>0.8 to 1.5</td> <td>0.8 to 1.7</td> <td>0.8 to 1.7</td> </tr> <tr> <td>C</td> <td>0.6 to 0.8</td> <td>0.9 to 1.2</td> <td>1.2 to 1.6</td> <td>1.8 to 2.5</td> </tr> </tbody> </table>  <p>Reflow-soldering</p> <table border="1"> <thead> <tr> <th>Type</th> <th>U2U1</th> <th>U4U2</th> <th>U6U3</th> <th>1005</th> <th>1608</th> <th>2012</th> <th>3216</th> <th>3225</th> <th>4532</th> </tr> </thead> <tbody> <tr> <td rowspan="2">Size</td> <td>L</td> <td>0.25</td> <td>0.4</td> <td>0.6</td> <td>1.0</td> <td>1.6</td> <td>2.0</td> <td>3.2</td> <td>4.5</td> </tr> <tr> <td>W</td> <td>0.125</td> <td>0.2</td> <td>0.3</td> <td>0.5</td> <td>0.8</td> <td>1.25</td> <td>1.6</td> <td>3.2</td> </tr> <tr> <td>A</td> <td>0.095~0.135</td> <td>0.15~0.25</td> <td>0.20~0.30</td> <td>0.45~0.55</td> <td>0.8~1.0</td> <td>0.8~1.2</td> <td>1.8~2.5</td> <td>1.8~2.5</td> <td>2.5~3.5</td> </tr> <tr> <td>B</td> <td>0.085~0.125</td> <td>0.15~0.20</td> <td>0.20~0.30</td> <td>0.40~0.50</td> <td>0.6~0.8</td> <td>0.8~1.2</td> <td>1.0~1.5</td> <td>1.0~1.5</td> <td>1.5~1.8</td> </tr> <tr> <td>C</td> <td>0.110~0.150</td> <td>0.15~0.30</td> <td>0.25~0.40</td> <td>0.45~0.55</td> <td>0.6~0.8</td> <td>0.9~1.6</td> <td>1.2~2.0</td> <td>1.8~3.2</td> <td>2.3~3.5</td> </tr> </tbody> </table> <p>Note: Recommended land size might be different according to the allowance of the size of the product.</p> <p>●LWDC: Recommended land dimensions for reflow-soldering (unit: mm)</p> <table border="1"> <thead> <tr> <th>Type</th> <th>0510</th> <th>0816</th> <th>1220</th> </tr> </thead> <tbody> <tr> <td rowspan="2">Size</td> <td>L</td> <td>0.52</td> <td>0.8</td> </tr> <tr> <td>W</td> <td>1.0</td> <td>1.6</td> </tr> <tr> <td>A</td> <td>0.18~0.22</td> <td>0.25~0.3</td> <td>0.5~0.7</td> </tr> <tr> <td>B</td> <td>0.2~0.25</td> <td>0.3~0.4</td> <td>0.4~0.5</td> </tr> <tr> <td>C</td> <td>0.9~1.1</td> <td>1.5~1.7</td> <td>1.9~2.1</td> </tr> </tbody> </table> 	Type	1608	2012	3216	3225	Size	L	1.6	2.0	3.2	W	0.8	1.25	1.6	A	0.8 to 1.0	1.0 to 1.4	1.8 to 2.5	1.8 to 2.5	B	0.5 to 0.8	0.8 to 1.5	0.8 to 1.7	0.8 to 1.7	C	0.6 to 0.8	0.9 to 1.2	1.2 to 1.6	1.8 to 2.5	Type	U2U1	U4U2	U6U3	1005	1608	2012	3216	3225	4532	Size	L	0.25	0.4	0.6	1.0	1.6	2.0	3.2	4.5	W	0.125	0.2	0.3	0.5	0.8	1.25	1.6	3.2	A	0.095~0.135	0.15~0.25	0.20~0.30	0.45~0.55	0.8~1.0	0.8~1.2	1.8~2.5	1.8~2.5	2.5~3.5	B	0.085~0.125	0.15~0.20	0.20~0.30	0.40~0.50	0.6~0.8	0.8~1.2	1.0~1.5	1.0~1.5	1.5~1.8	C	0.110~0.150	0.15~0.30	0.25~0.40	0.45~0.55	0.6~0.8	0.9~1.6	1.2~2.0	1.8~3.2	2.3~3.5	Type	0510	0816	1220	Size	L	0.52	0.8	W	1.0	1.6	A	0.18~0.22	0.25~0.3	0.5~0.7	B	0.2~0.25	0.3~0.4	0.4~0.5	C	0.9~1.1	1.5~1.7	1.9~2.1
Type	1608	2012	3216	3225																																																																																																												
Size	L	1.6	2.0	3.2																																																																																																												
	W	0.8	1.25	1.6																																																																																																												
A	0.8 to 1.0	1.0 to 1.4	1.8 to 2.5	1.8 to 2.5																																																																																																												
B	0.5 to 0.8	0.8 to 1.5	0.8 to 1.7	0.8 to 1.7																																																																																																												
C	0.6 to 0.8	0.9 to 1.2	1.2 to 1.6	1.8 to 2.5																																																																																																												
Type	U2U1	U4U2	U6U3	1005	1608	2012	3216	3225	4532																																																																																																							
Size	L	0.25	0.4	0.6	1.0	1.6	2.0	3.2	4.5																																																																																																							
	W	0.125	0.2	0.3	0.5	0.8	1.25	1.6	3.2																																																																																																							
A	0.095~0.135	0.15~0.25	0.20~0.30	0.45~0.55	0.8~1.0	0.8~1.2	1.8~2.5	1.8~2.5	2.5~3.5																																																																																																							
B	0.085~0.125	0.15~0.20	0.20~0.30	0.40~0.50	0.6~0.8	0.8~1.2	1.0~1.5	1.0~1.5	1.5~1.8																																																																																																							
C	0.110~0.150	0.15~0.30	0.25~0.40	0.45~0.55	0.6~0.8	0.9~1.6	1.2~2.0	1.8~3.2	2.3~3.5																																																																																																							
Type	0510	0816	1220																																																																																																													
Size	L	0.52	0.8																																																																																																													
	W	1.0	1.6																																																																																																													
A	0.18~0.22	0.25~0.3	0.5~0.7																																																																																																													
B	0.2~0.25	0.3~0.4	0.4~0.5																																																																																																													
C	0.9~1.1	1.5~1.7	1.9~2.1																																																																																																													

(2) Examples of good and bad solder application

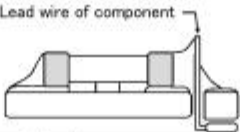
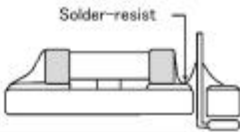
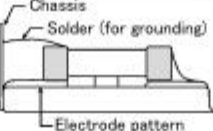
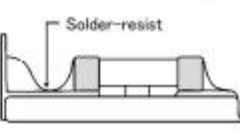
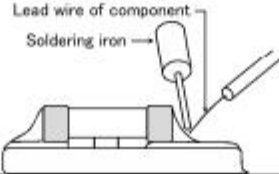
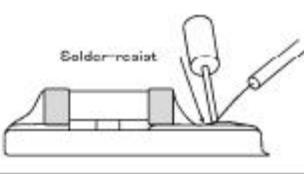
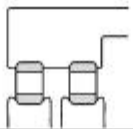
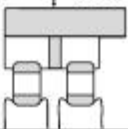
Item	Not recommended	Recommended
Mixed mounting of SMD and leaded components		
Component placement close to the chassis		
Hand-soldering of leaded components near mounted components		
Horizontal component placement		

◆ Pattern configurations (Capacitor layout on PCBs)

1-1. The following is examples of good and bad capacitor layouts ; capacitors shall be located to minimize any possible mechanical stresses from board warp or deflection.

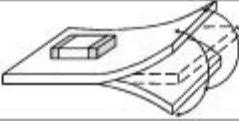
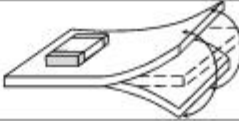
Items	Not recommended	Recommended
Deflection of board		

Place the product at a right angle to the direction of the anticipated mechanical stress.

1-2. The amount of mechanical stresses given will vary depending on capacitor layout. Please refer to diagram below.

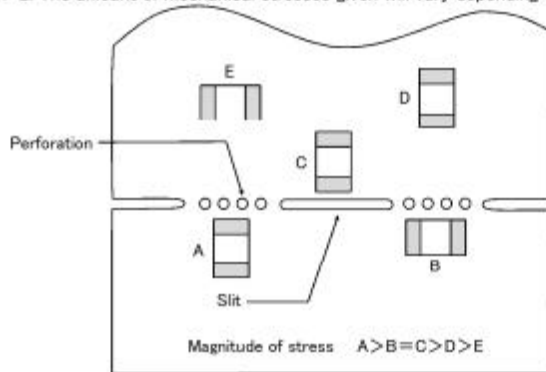

1-3. When PCB is split, the amount of mechanical stress on the capacitors can vary according to the method used. The following methods are listed in order from least stressful to most stressful: push-back, slit, V-grooving, and perforation. Thus, please consider the PCB, split methods as well as chip location.

### 3. Mounting

#### Precautions

- ◆ Adjustment of mounting machine
  1. When capacitors are mounted on PCB, excessive impact load shall not be imposed on them.
  2. Maintenance and inspection of mounting machines shall be conducted periodically.
- ◆ Selection of Adhesives
  1. When chips are attached on PCBs with adhesives prior to soldering, it may cause capacitor characteristics degradation unless the following factors are appropriately checked : size of land patterns, type of adhesive, amount applied, hardening temperature and hardening period. Therefore, please contact us for further information.

#### Technical considerations

- ◆ Adjustment of mounting machine
  1. When the bottom dead center of a pick-up nozzle is too low, excessive force is imposed on capacitors and causes damages. To avoid this, the following points shall be considerable.
    - (1) The bottom dead center of the pick-up nozzle shall be adjusted to the surface level of PCB without the board deflection.
    - (2) The pressure of nozzle shall be adjusted between 1 and 3 N static loads.
    - (3) To reduce the amount of deflection of the board caused by impact of the pick-up nozzle, supporting pins or back-up pins shall be used on the other side of the PCB. The following diagrams show some typical examples of good and bad pick-up nozzle placement:

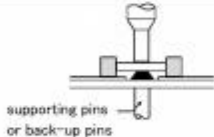
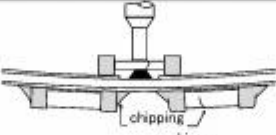
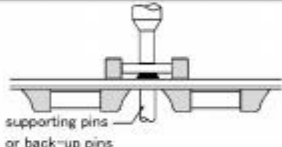
Item	Improper method	Proper method
Single-sided mounting		
Double-sided mounting		

2. As the alignment pin is worn out, adjustment of the nozzle height can cause chipping or cracking of capacitors because of mechanical impact on the capacitors. To avoid this, the monitoring of the width between the alignment pins in the stopped position, maintenance, check and replacement of the pin shall be conducted periodically.

- ◆ Selection of Adhesives
 

Some adhesives may cause IR deterioration. The different shrinkage percentage of between the adhesive and the capacitors may result in stresses on the capacitors and lead to cracking. Moreover, too little or too much adhesive applied to the board may adversely affect components. Therefore, the following precautions shall be noted in the application of adhesives.

- (1) Required adhesive characteristics
  - a. The adhesive shall be strong enough to hold parts on the board during the mounting & solder process.
  - b. The adhesive shall have sufficient strength at high temperatures.
  - c. The adhesive shall have good coating and thickness consistency.
  - d. The adhesive shall be used during its prescribed shelf life.
  - e. The adhesive shall harden rapidly.
  - f. The adhesive shall have corrosion resistance.
  - g. The adhesive shall have excellent insulation characteristics.
  - h. The adhesive shall have no emission of toxic gases and no effect on the human body.
- (2) The recommended amount of adhesives is as follows;

[Recommended condition]

Figure	2012/3216 case sizes as examples
a	0.3mm min
b	100 to 120 μm
c	Adhesives shall not contact land

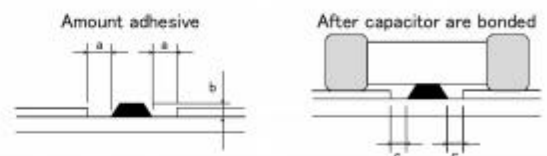

### 4. Soldering

#### Precautions

- ◆ Selection of Flux
 

Since flux may have a significant effect on the performance of capacitors, it is necessary to verify the following conditions prior to use:

  - (1) Flux used shall be less than or equal to 0.1 wt% ( in Cl equivalent ) of halogenated content. Flux having a strong acidity content shall not be applied.
  - (2) When shall capacitors are soldered on boards, the amount of flux applied shall be controlled at the optimum level.
  - (3) When water-soluble flux is used, special care shall be taken to properly clean the boards.
- ◆ Soldering
 

Temperature, time, amount of solder, etc. shall be set in accordance with their recommended conditions.  
 Sn-Zn solder paste can adversely affect MLCC reliability.  
 Please contact us prior to usage of Sn-Zn solder.

◆ Selection of Flux

- 1-1. When too much halogenated substance (Chlorine, etc.) content is used to activate flux, or highly acidic flux is used, it may lead to corrosion of terminal electrodes or degradation of insulation resistance on the surfaces of the capacitors.
- 1-2. Flux is used to increase solderability in wave soldering. However if too much flux is applied, a large amount of flux gas may be emitted and may adversely affect the solderability. To minimize the amount of flux applied, it is recommended to use a flux bubbling system.
- 1-3. Since the residue of water-soluble flux is easily dissolved in moisture in the air, the residues on the surfaces of capacitors in high humidity conditions may cause a degradation of insulation resistance and reliability of the capacitors. Therefore, the cleaning methods and the capability of the machines used shall also be considered carefully when water-soluble flux is used.

◆ Soldering

- Ceramic chip capacitors are susceptible to thermal shock when exposed to rapid or concentrated heating or rapid cooling.
- Therefore, the soldering must be conducted with great care so as to prevent malfunction of the components due to excessive thermal shock.
- Preheating : Capacitors shall be preheated sufficiently, and the temperature difference between the capacitors and solder shall be within 130°C.
- Cooling : The temperature difference between the capacitors and cleaning process shall not be greater than 100°C.

[Reflow soldering]

【Recommended conditions for eutectic soldering】

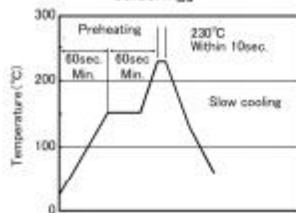

【Recommended condition for Pb-free soldering】

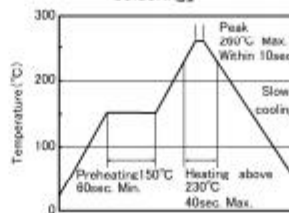

Caution

- ① The ideal condition is to have solder mass (fillet) controlled to 1/2 to 1/3 of the thickness of a capacitor.
- ② Because excessive dwell times can adversely affect solderability, soldering duration shall be kept as close to recommended times as possible. soldering for 2 times.

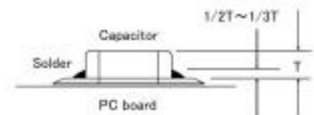

Technical considerations

[Wave soldering]

【Recommended conditions for eutectic soldering】

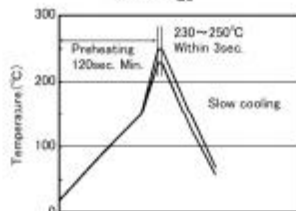

【Recommended condition for Pb-free soldering】

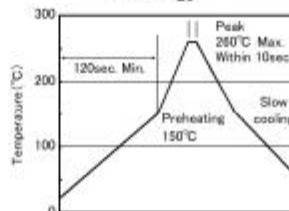

Caution

- ① Wave soldering must not be applied to capacitors designated as for reflow soldering only. soldering for 1 times.

[Hand soldering]

【Recommended conditions for eutectic soldering】

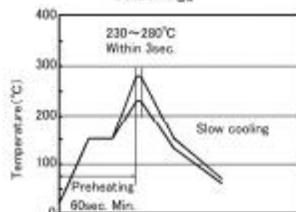

【Recommended condition for Pb-free soldering】

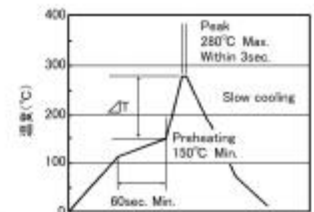
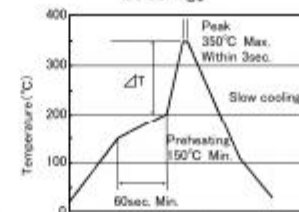

3216 type or less      ΔT ≤ 150°C

3225 type or more      ΔT ≤ 130°C

Caution

- ① Use a 20W soldering iron with a maximum tip diameter of 1.0 mm.
- ② The soldering iron shall not directly touch capacitors. soldering for 1 times.

5. Cleaning	
Precautions	<p>◆Cleaning conditions</p> <ol style="list-style-type: none"> <li>When PCBs are cleaned after capacitors mounting, please select the appropriate cleaning solution in accordance with the intended use of the cleaning. (e.g. to remove soldering flux or other materials from the production process.)</li> <li>Cleaning condition shall be determined after it is verified by using actual cleaning machine that the cleaning process does not affect capacitor's characteristics.</li> </ol>
Technical considerations	<ol style="list-style-type: none"> <li>The use of inappropriate cleaning solutions can cause foreign substances such as flux residue to adhere to capacitors or deteriorate their outer coating, resulting in a degradation of the capacitor's electrical properties (especially insulation resistance).</li> <li>Inappropriate cleaning conditions (insufficient or excessive cleaning) may adversely affect the performance of the capacitors. In the case of ultrasonic cleaning, too much power output can cause excessive vibration of PCBs which may lead to the cracking of capacitors or the soldered portion, or decrease the terminal electrodes' strength. Therefore, the following conditions shall be carefully checked:            Ultrasonic output : 20 W/ℓ or less      Ultrasonic frequency : 40 kHz or less            Ultrasonic washing period : 5 min. or less</li> </ol>

6. Resin coating and mold	
Precautions	<ol style="list-style-type: none"> <li>With some type of resins, decomposition gas or chemical reaction vapor may remain inside the resin during the hardening period or while left under normal storage conditions resulting in the deterioration of the capacitor's performance.</li> <li>When a resin's hardening temperature is higher than capacitor's operating temperature, the stresses generated by the excessive heat may lead to damage or destruction of capacitors. The use of such resins, molding materials etc. is not recommended.</li> </ol>

7. Handling	
Precautions	<p>◆Splitting of PCB</p> <ol style="list-style-type: none"> <li>When PCBs are split after components mounting, care shall be taken so as not to give any stresses of deflection or twisting to the board.</li> <li>Board separation shall not be done manually, but by using the appropriate devices.</li> </ol> <p>◆Mechanical considerations</p> <p>Be careful not to subject capacitors to excessive mechanical shocks.</p> <p>(1) If ceramic capacitors are dropped onto a floor or a hard surface, they shall not be used.</p> <p>(2) Please be careful that the mounted components do not come in contact with or bump against other boards or components.</p>

8. Storage conditions	
Precautions	<p>◆Storage</p> <ol style="list-style-type: none"> <li>To maintain the solderability of terminal electrodes and to keep packaging materials in good condition, care must be taken to control temperature and humidity in the storage area. Humidity should especially be kept as low as possible.           <ul style="list-style-type: none"> <li>Recommended conditions                Ambient temperature : Below 30°C      Humidity : 20 to 70% RH</li> </ul>           The ambient temperature must be kept from 5 to 40°C. Even under ideal storage conditions, solderability of capacitor is deteriorated as time passes, so capacitors shall be used within 6 months from the time of delivery.           <ul style="list-style-type: none"> <li>Ceramic chip capacitors shall be kept where no chlorine or sulfur exists in the air.</li> </ul> </li> <li>The capacitance values of high dielectric constant capacitors will gradually decrease with the passage of time, so care shall be taken to design circuits. Even if capacitance value decreases as time passes, it will get back to the initial value by a heat treatment at 150°C for 1hour.</li> </ol>
Technical considerations	<p>If capacitors are stored in a high temperature and humidity environment, it might rapidly cause poor solderability due to terminal oxidation and quality loss of taping/packaging materials. For this reason, capacitors shall be used within 6 months from the time of delivery. If exceeding the above period, please check solderability before using the capacitors.</p>

※RCR-2335□ (Safety Application Guide for fixed ceramic capacitors for use in electronic equipment) is published by JEITA.  
Please check the guide regarding precautions for deflection test, soldering by spot heat, and so on.