

客户图

NO.	ECN NO.	DESCRIPTION	DATE
1			

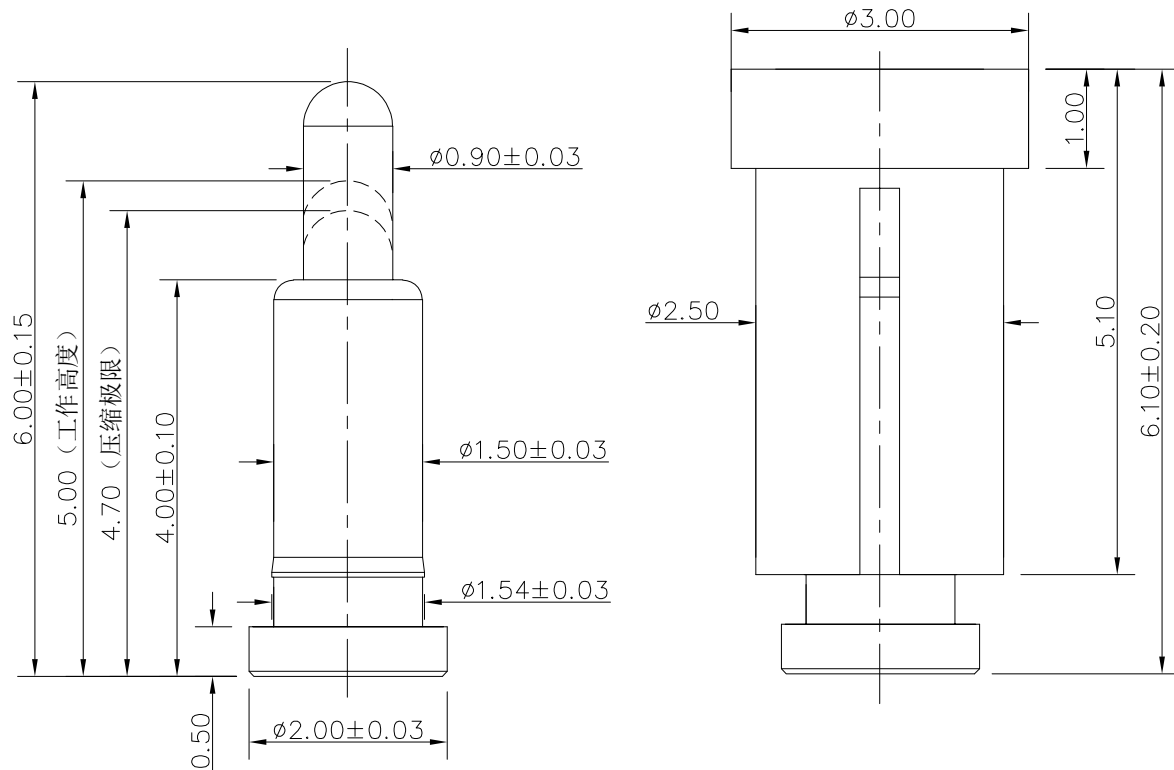

Note:

- Material(材料):**
 - Barrel: Brass C3604 (针管: 黄铜 C3604)
 - Plunger: Brass C3604 (针头: 黄铜 C3604)
 - Spring: SUS304 (弹簧: SUS304)
- Plating(电镀):**
 - Barrel: 3u' Au over 50~80u' Ni (针管: 镀金3u', 镍底50~80u'.)
 - Plunger: 3u' Au over 50~80u' Ni (针头: 镀金3u', 镍底50~80u'.)
 - Spring: Gold flash (弹簧: 镀金)
- Electrical(电气特性):**
 - Rated Current & Voltage: DC 12V;3A (额定电压&电流: 直流12V,3A)
 - Contact Resistance: 50 mohm Max. at working height. (接触电阻: 最大50毫欧 (在工作高度状态下))
- Mechanical(机械性能):**
 - Force: 130g \pm 20% at working height. (130g \pm 20% 在工作高度)。
 - Durability: 10.000 cycles(min) (寿命: 10000次)
- WorkTemperture(工作环境):**
 - Withstanding Higt Temperature: 280 \circ
 - Operational Temperature: -20 \circ ~ +70 \circ

深圳市鑫探技术有限公司



HTTP://WWW.XYZPOGOPIN.COM

TEL:0755-28773277 FAX:0755-28891353

SCALE:	N/A	UNIT	mm
SHEET:	1 of 1	PROJECTION	
DATE:	2024.12.23	VER.	A.0

THE UNMARKED TOLERANCE ARE AS BELOW :			
LENGTH		ANGLE	
X.XX	$\pm 0.05\text{mm}$	X.XX	$\pm 0.50^\circ$
X.X	$\pm 0.10\text{mm}$	X.X	$\pm 1.00^\circ$
X.	$\pm 0.20\text{mm}$	X.	$\pm 2.00^\circ$

DESIGNED BY:		DWG. NO.	YZ01215060R-06
CHECKED BY:		TITLE:	Pogo pin
APPROVED BY:			