

NOTE:

- MATERIAL SPECIFICATION:
 - HOUSING: HIGH TEMPERATURE RESISTANT PLASTIC, UL94 V-0.
 - TERMINAL: COPPER ALLOY (C18150)
 - MID PLATE: STAINLESS STEEL (SUS301)
 - FRONT SHELL: STAINLESS STEEL (SUS304)
- PLATING SPECIFICATION:
 - TERMINAL:
 - Ni 50u" MIN. UNDER PLATED OVER ALL.
 - Au 1u" PLATED ON THE FUNCTIONAL AREA OF CONTACT.
 - Au G/F PLATED ON THE SOLDER AREA.
 - FRONT SHELL:
 - Ni 30u" MIN. UNDER PLATED OVER ALL.
 - MID PLATE PLATE:
 - CLEAR ONLY
- MECHANICAL PERFORMANCE,
 - INSERTION FORCE: 0.5~2.0kgf.
 - REMOVAL FORCE: 0.8kgf~2.0kgf.
 - DURABILITY: 10000 CYCLES.
- ELECTRICAL PERFORMANCE,
 - VOLTAGE RATING: 5V.
CURRENT RATING: 5A.
 - LLCR:
 - VBUS & GND PINS AND OTHER PINS: 40mA/PIN MAX.
 - LLCR MAX. CHANGE OF ALL PINS: 10mA.
 - INSULATION RESISTANCE: 100MΩ MIN
 - DIELECTRIC WITHSTAND VOLTAGE, AC 100V FOR 1 MINUTE.
- ENVIRONMENTAL PERFORMANCE:
 - OPERATING TEMPERATURE: -40C~+85°C.
- IR REFLOW:
 - THE PEAK TEMPERATURE ON THE BOARD SHALL BE MAINTAINED FOR 10 SECONDS AT 260°C.

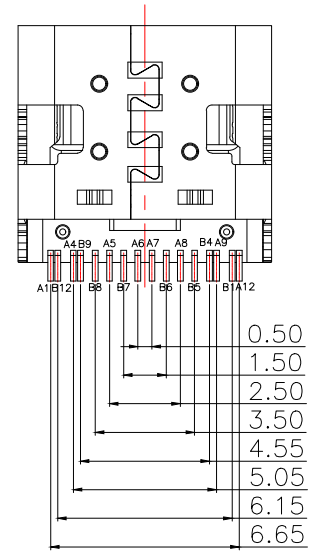

MANUFACTURE DWG		 东莞市讯普电子科技有限公司 DongGuan XunPu Electronics Co., Ltd	
UNLESS OTHERWISE SPECIFIED TOLERANCES			TITLE: USB CF 16PIN (L=8.35) WITH POST
			PAR TYPE-C-304DT-WSC1835
			DWN Lucas
			CHKD Ethan
DECIMALS:	ANGLES:		APVD Jacob
.X:±0.30	X.:±10°		SCALE 1:1 UNIT:MM
.XX:±0.20	X.X':±8°		SIZE:A4
.XXX:±0.10	X.XX':±5°		SHEET:1F3
		CUSTOMER COPY	REV:A

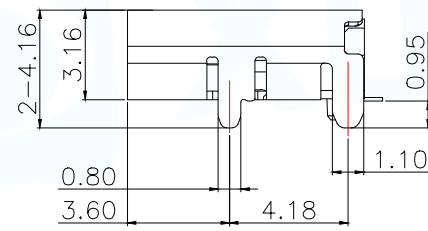
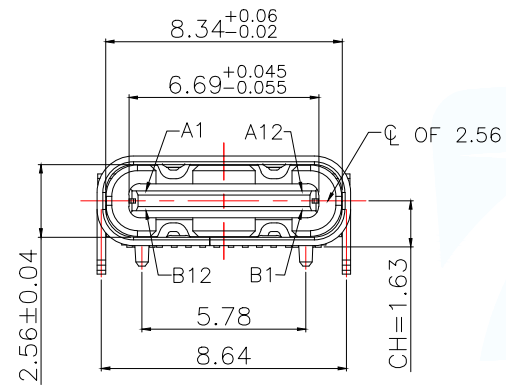
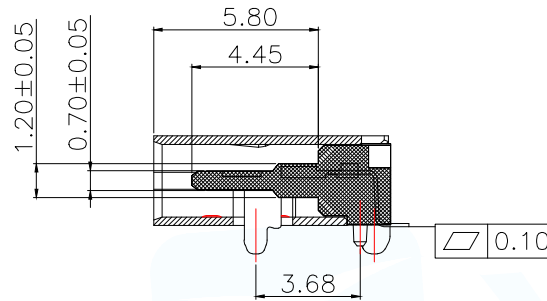

SECTION:A-A

USB TYPE-C PIN ASSIGNMENTS

PIN NUMBER	SIGNAL NAME	PIN NUMBER	SIGNAL NAME
A1	GND	B12	GND
A4	VBUS	B9	VBUS
A5	CC1	B8	SBU2
A6	Dp1	B7	Dn2
A7	Dn1	B6	Dp2
A8	SBU1	B5	CC2
A9	VBUS	B4	VBUS
A12	GND	B1	GND

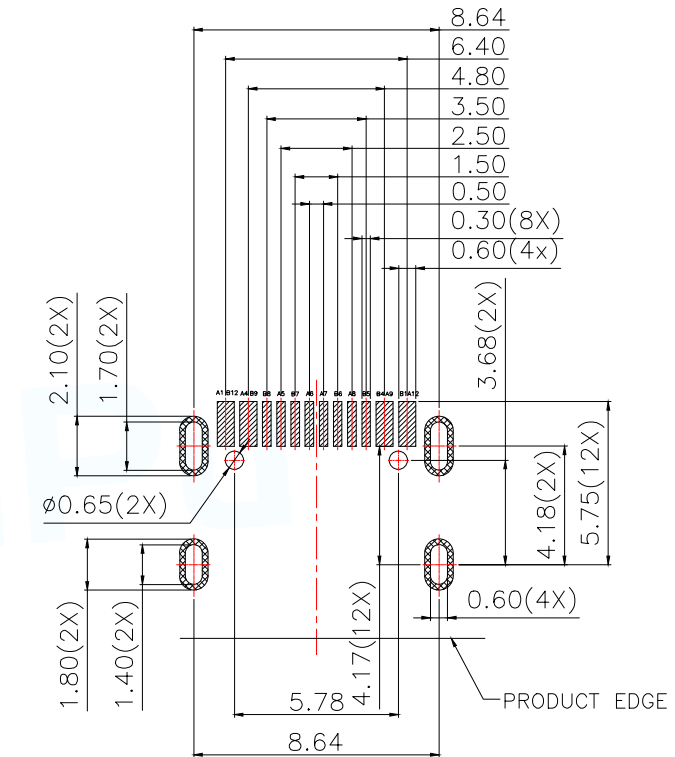

RECOMMENDED PCB LAYOUT(TOP VIEW)
THICKNESS 1.00MM;DEFAULT TOLERANCE:±0.05

MANUFACTURE DWG		 东莞市讯普电子科技有限公司 DongGuan XunPu Electronics Co.,Ltd	
UNLESS OTHERWISE SPECIFIED TOLERANCES		TITLE:USB CF 16PIN (L=8.35) WITH POST	
DECIMALS:	ANGLES:	PAR	TYPE-C-304DT-W_SCL835
.X:±0.30	X':±10°	DWN	Lucas
.XX:±0.20	X.X':±8°	CHKD	Ethan
.XXX:±0.10	X.XX':±5°	APVD	Jacob
CUSTOMER COPY		SCALE 1:1	UNIT:MM
		SIZE:A4	SHEET:2F3
			REV:A

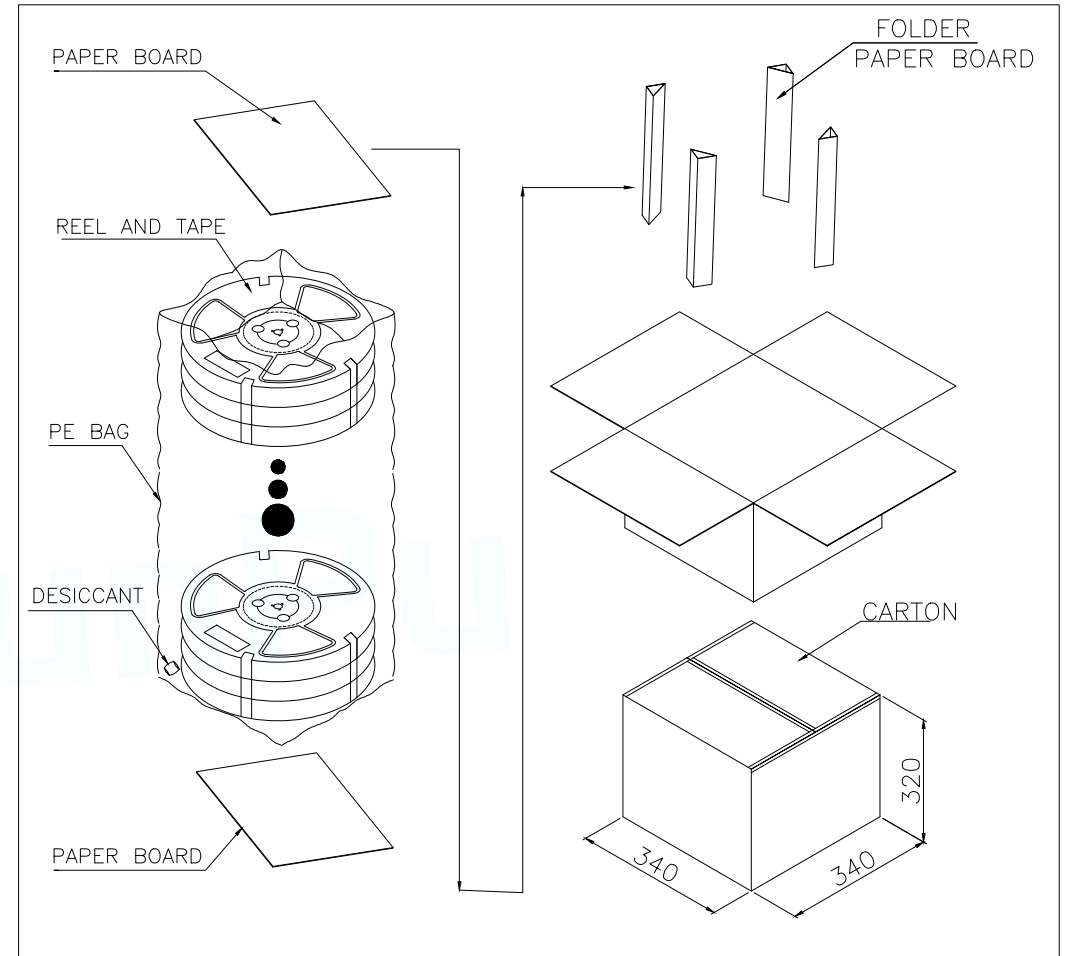
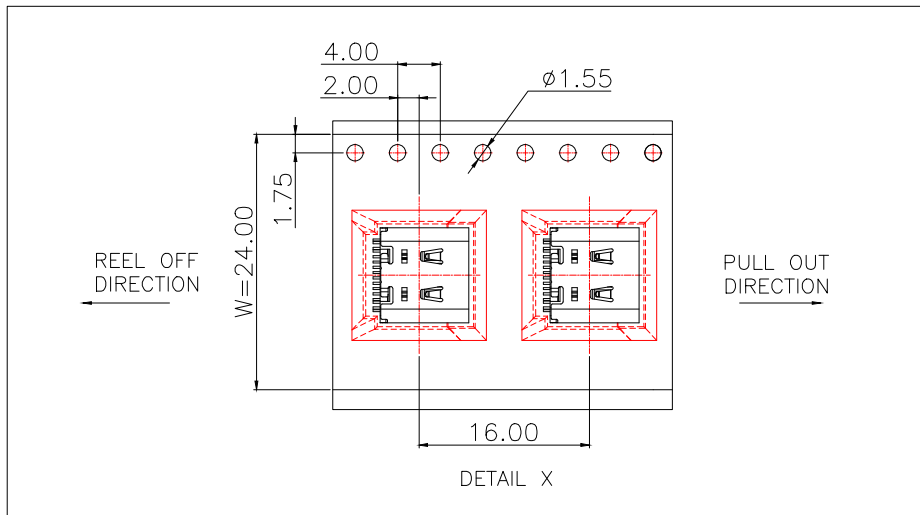
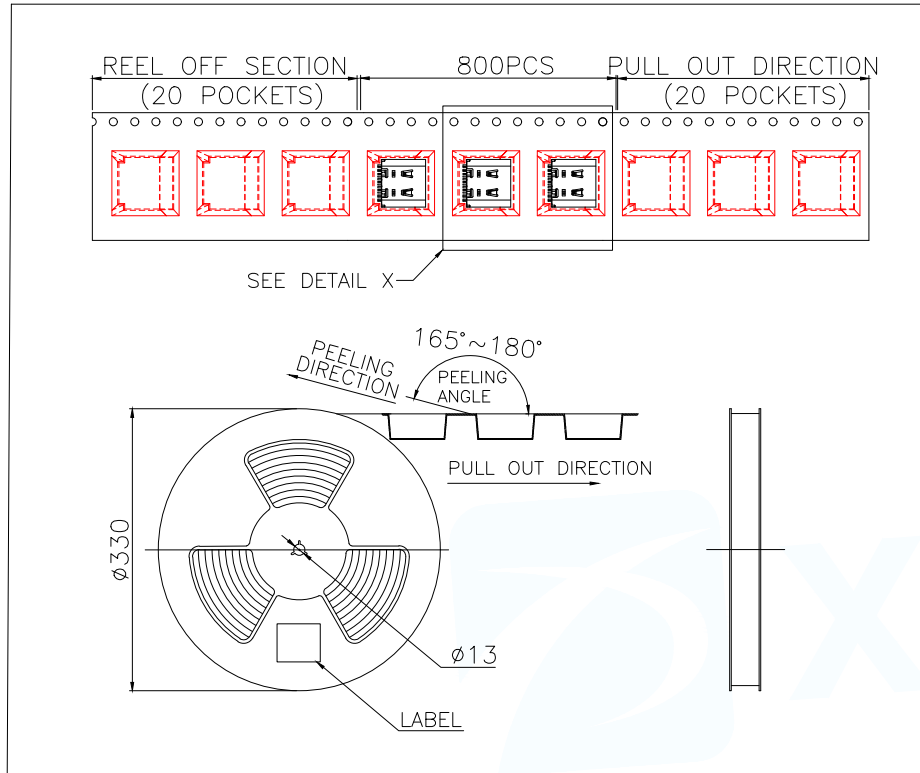

		REEL	CARTON
CONNECTOR (PCS)		800	8000
MANUFACTURE DWG	东莞市讯普电子科技有限公司 DongGuan XunPu Electronics Co.,Ltd		
UNLESS OTHERWISE SPECIFIED TOLERANCES		TITLE:USB CF 16PIN (L=8.35) WITH POST	
		PAR	TYPE-C-304DT-W5CL835
DECIMALS:	ANGLES:	DWN	Lucas
.X:±0.30	X.'':±10'	CHKD	Ethan
.XX:±0.20	X.X':±8'	APVD	Jacob
.XXX:±0.10	X.XX':±5'	SCALE 1:1	UNIT:MM
	CUSTOMER COPY	SIZE:A4	SHEET:3F3
			REV:A