

NO.	ECN NO.	DESCRIPTION	DATE

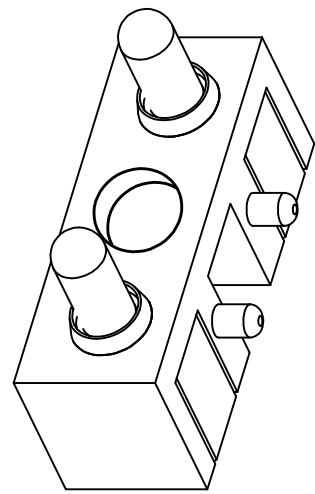

Note:

- Material (材料):  
 Barrel: Brass C3604 (针管: 黄铜 C3604)  
 Plunger: Brass C3604 (针头: 黄铜 C3604)  
 Spring: SUS304 (弹簧: SUS304)
- Plating (电镀):  
 Barrel: 3u' Au over 50~80u' Ni (针管: 镀金3u', 镍底50~80u'.)  
 Plunger: 3u' Au over 50~80u' Ni (针头: 镀金3u', 镍底50~80u'.)  
 Spring: No plated (弹簧: 不电镀)
- Electrical (电气特性):  
 Rated Current & Voltage: DC 12V;1A (额定电压&电流: 直流12V,1A)  
 Contact Resistance: 50 mohm Max. at working height.  
 接触电阻: 最大50毫欧 (在工作高度状态下)
- Mechanical (机械性能):  
 Force: 120g±20% at working height. (120g±20% 在工作高度).  
 Durability: 10.000 cycles(min) (寿命: 10000次)
- Work Temperature (工作环境):  
 Withstanding Higt Temperature: 280°C  
 Operational Temperature: -20°C ~ +70°C

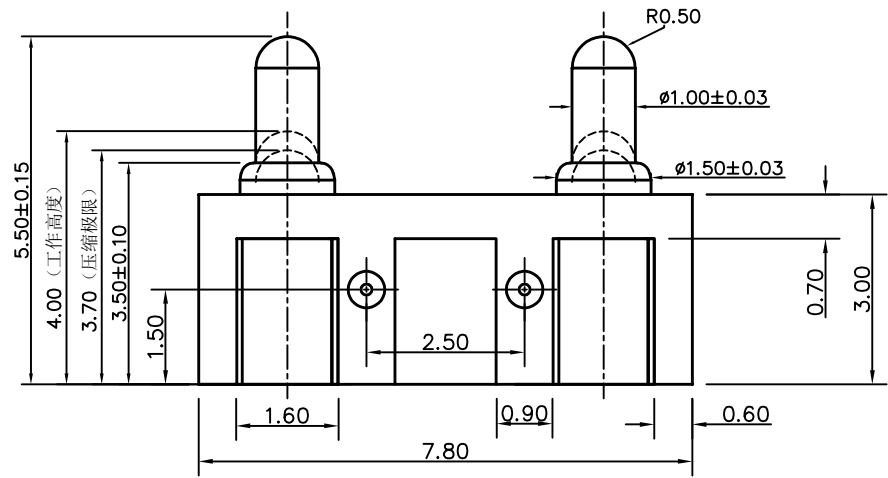
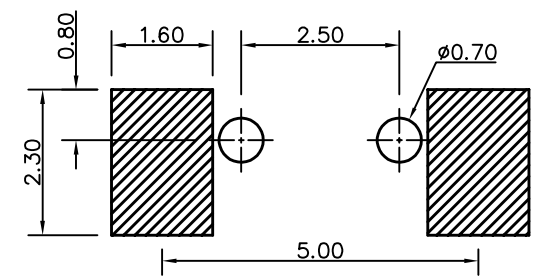
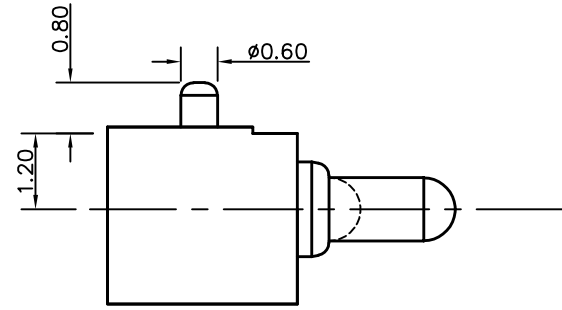
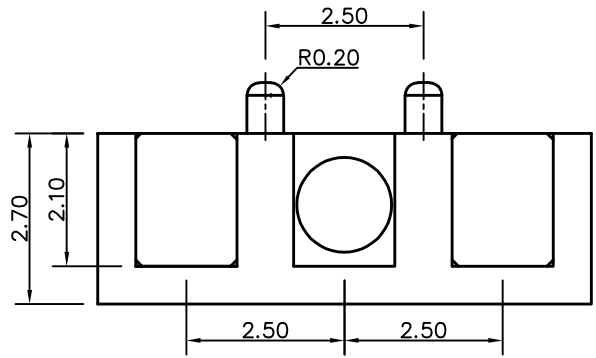

深圳市鑫扬泽电子有限公司



SCALE:	N/A	UNIT	mm
SHEET:	1 of 1	PROJECTION	
DATE:	2017.11.14	VER.	D.0

THE UNMARKED TOLERANCE ARE AS BELOW :			
LENGTH		ANGLE	
X.XX	±0.05mm	X.XX	±0.5°
X.X	±0.10mm	X.X	±1.0°
X.	±0.20mm	X.	±2.0°

DESIGNED BY:		DWG. NO.	YZ13415055F-02050-02
CHECKED BY:		TITLE:	Pogo pin 连接器
APPROVED BY:			

HTTP://WWW.XYZPOGOPIN.COM  
 TEL:0755-28773277 FAX:0755-28891353