

客户图

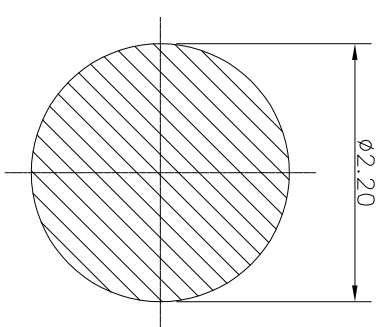
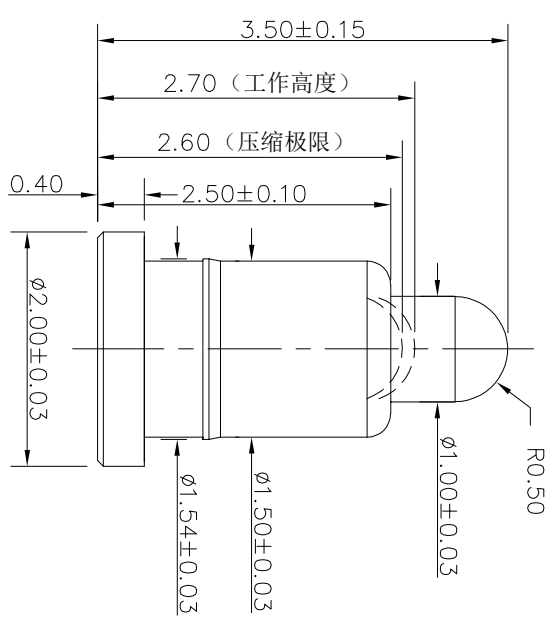

RECOMMENDED PCB LAYOUT

Note:

- 1: Material(材料) :
 Cap: PA46+30%GF (胶盖: PA46)
 Barrel: Brass C3604 (针管: 黄铜 C3604)
 Plunger: Brass C3604 (针头: 黄铜 C3604)
 Spring: SUS304 (弹簧: SUS304)
- 2: Plating(电镀) :
 Barrel: 3u' Au over 50~80u' Ni(针管: 镀金3u', 镍底50~80u'.)
 Plunger: 3u' Au over 50~80u' Ni (针头: 镀金3u', 镍底50~80u'.)
- 3: Electrical(电气特性) :
 Spring: No flash (弹簧: 不电镀)
 Rated Current & Voltage: DC 12V,1A (额定电压&电流: 直流12V,1A)
 Contact Resistance: 50 mohm Max. at working height.
 接触电阻: 最大50毫欧 (在工作高度状态下)
- 4: Mechanical(机械性能) :
 Force: 30g±20% at working height. (30g±20% 在工作高度)。
 Durability: 10,000 cycles(min) (寿命: 10000次)
- 5: WorkTemperature(工作环境):
 Withstanding Higt Temperature: 280°C
 Operational Temperature: -20°C~ +70°C

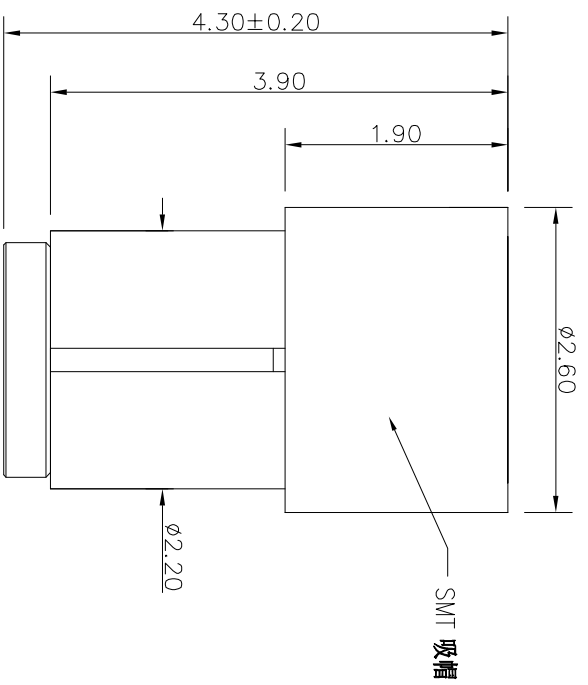

NO.	ECN NO.	DESCRIPTION	DATE

深圳市鑫探技术有限公司

HTTP://WWW.XYZFOGOPIN.COM
 TEL: 0755-28773277 FAX: 0755-28891353



SCALE:	N/A	UNIT	mm
SHEET:	1 of 1	PROJECTION	☉
DATE:	2026.04.11	VER.	A.0
THE UNMARKED TOLERANCE ARE AS BELOW :			
LENGTH		ANGLE	
XXX	±0.05mm	XXX	±0.5°
X X	±0.10mm	X X	±1.0°
X	±0.20mm	X.	±2.0°
DESIGNED BY:	CHECKED BY:	DWG. NO.	YZ00315035R-11
APPROVED BY:	TITLE:	成品图	