

Applications

- Supply line switching
- Battery charger
- DC/DC converter
- LCD backlighting.

Features

- Low collector-to-emitter saturation voltage.
- High current capability
- Higher efficiency leading to less heat generation
- Reduced printed-circuit board requirements.
- Complement the PBSS4350X

SOT-89

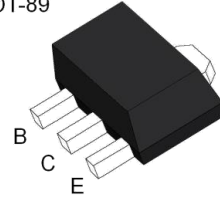

Marking :

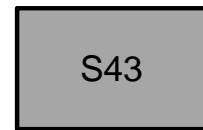

MAXIMUM RATINGS AND ELECTRICAL CHARACTERISTICS

Absolute Maximum Ratings (Ta=25°C)

Parameter	Symbol	Value	Unit
Collector-base voltage	BV_{CBO}	50	V
Collector-emitter voltage	BV_{CEO}	50	V
Emitter-base voltage	BV_{EBO}	5	V
Collector current (DC)	I_C	3	A
Collector current (Pulse)	I_{CP}	5	A
Base current (DC)	I_B	0.5	A
Total power dissipation	Note1	0.55	W
	Note2	1	
	Note3	1.4	
	Note4	1.6	
Junction temperature	T_j	150	°C
Storage temperature	T_{stg}	-55~150	°C

Electrical Characteristics $T_A=25^{\circ}\text{C}$ unless otherwise noted

Parameter	Symbol	Conditions	Min	Typ	Max	Unit
Collector-base breakdown voltage	BV_{CBO}	$I_C = 100\mu\text{A}, I_E = 0$	50			V
Collector-emitter breakdown voltage	BV_{CEO}	$I_C = 1\text{mA}, I_B = 0$	50			V
Emitter-base breakdown voltage	BV_{EBO}	$I_E = 100\mu\text{A}, I_C = 0$	5			V
Collector cut-off current	I_{CBO}	$V_{CB} = 50\text{V}, I_E = 0$			100	nA
Emitter cut-off current	I_{EBO}	$V_{EB} = 5\text{V}, I_C = 0$			100	nA
DC current gain*	h_{FE}	$V_{CE} = 2\text{V}, I_B = 0.1\text{A}$	300			
		$V_{CE} = 2\text{V}, I_B = 0.5\text{A}$	300			
		$V_{CE} = 2\text{V}, I_B = 1\text{A}$	300		700	
		$V_{CE} = 2\text{V}, I_B = 2\text{A}$	200			
		$V_{CE} = -2\text{V}, I_B = -3\text{A}$	100			
Collector-emitter saturation voltage*	$V_{CE(sat)}$	$I_C = 500\text{mA}, I_B = 50\text{mA}$			80	mV
		$I_C = 1\text{A}, I_B = 50\text{mA}$			160	
		$I_C = 2\text{A}, I_B = 100\text{mA}$			280	
		$I_C = 2\text{A}, I_B = 200\text{mA}$			260	
		$I_C = 3\text{A}, I_B = 300\text{mA}$			370	
Equivalent on-resistance	$R_{CE(sat)}$	$I_C = 2\text{A}, I_B = 200\text{mA}$			130	m Ω
Base-emitter saturation voltage*	$V_{BE(sat)}$	$I_C = 2\text{A}, I_B = 100\text{mA}$			1.1	V
		$I_C = 3\text{A}, I_B = 300\text{mA}$			1.2	
Base-emitter turn on voltage	$V_{BE(on)}$	$V_{CE} = 2\text{V}, I_C = 1\text{A}$			1.1	V
Transition frequency	f_T	$V_{CE} = 5\text{V}, I_E = 100\text{mA}$ $f = 100\text{MHz}$	100			MHz
Collector output Capacitance	C_{ob}	$V_{CB} = 10\text{V}, I_E = 0, f = 1\text{MHz}$			35	pF

* Pulse Test: $PW=300\mu\text{s}$, duty Cycle=2% Pulsed

Thermal Characteristics

Parameter	Symbol	Conditions	Value	Unit
Thermal resistance from junction to ambient	$R_{th(j-a)}$	in free air; Note1	225	$^{\circ}\text{C} / \text{W}$
		Note2	125	
		Note3	90	
		Note4	80	
Thermal resistance from junction to soldering point	$R_{th(j-s)}$		16	$^{\circ}\text{C} / \text{W}$

Notes

- 1.Device mounted on a printed-circuit board, single sided copper, tinplated and standard footprint.
- 2.Device mounted on a printed-circuit board, single sided copper, tinplated and mounting pad for collector 1cm^2
- 3.Device mounted on a printed-circuit board, single sided copper, tinplated and mounting pad for collector 6cm^2
- 4.Device mounted on a ceramic printed-circuit board 7cm^2 , single-sided copper, tinplated.

RATING AND CHARACTERISTIC CURVES

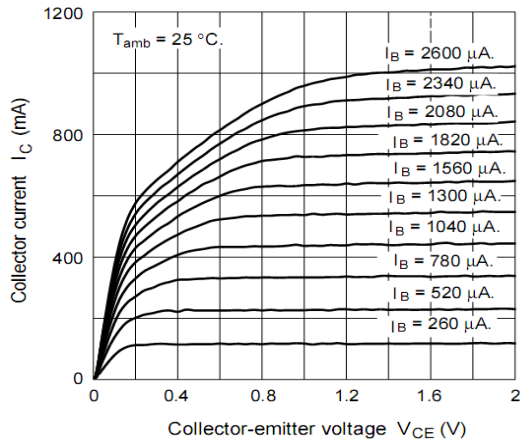

Figure 1. Static Characteristic

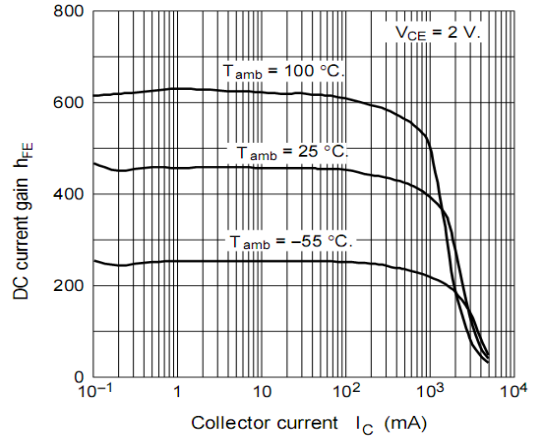

Figure 2. DC current Gain

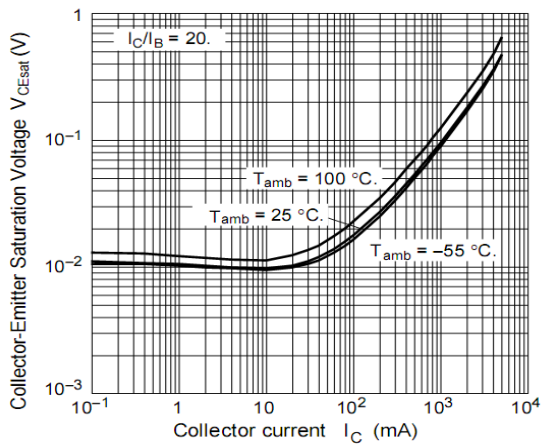

Figure 3. Collector-Emitter Saturation Voltage

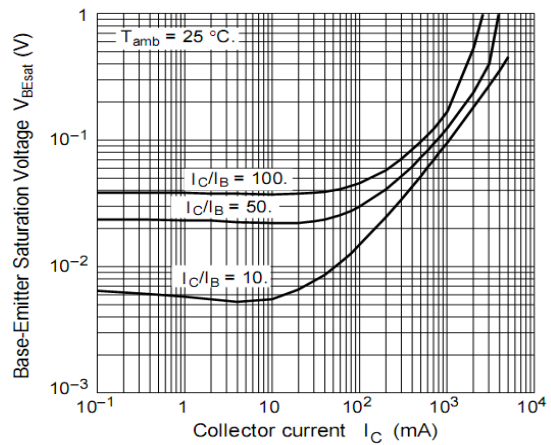

Figure 4. Base-Emitter Saturation Voltage

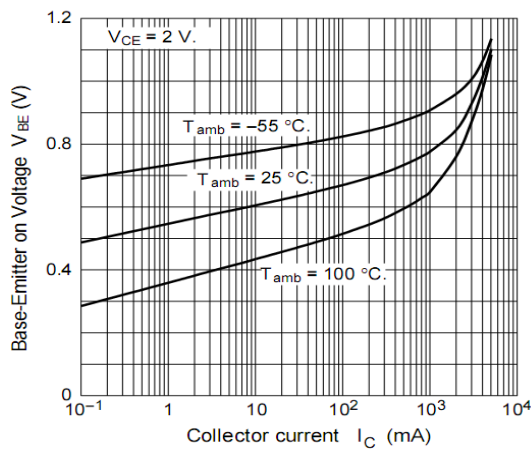

Figure 5. Base-Emitter on Voltage

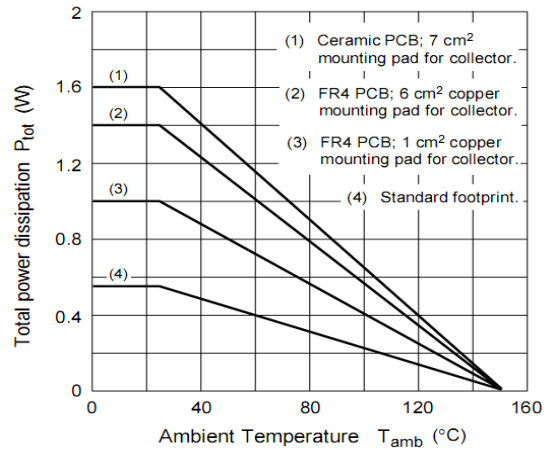
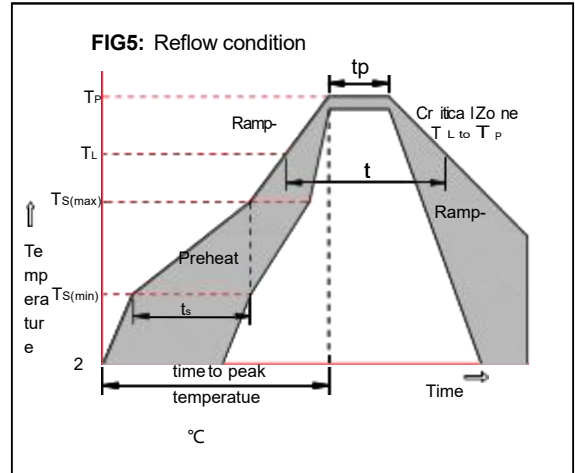

Figure 6. Power derating curves.

Soldering parameters

Reflow Condition		Pb-Free assembly (see as below)
Pre Heat	-Temperature Min ($T_{s(min)}$)	+150°C
	-Temperature Max($T_{s(max)}$)	+200°C
	-Time (Min to Max) (ts)	60-180 secs.
Average ramp up rate (Liquid us Temp (T_L) to peak)		3°C/sec. Max
$T_{s(max)}$ to T_L - Ramp-up Rate		3°C/sec. Max
Reflow	-Temperature(T_L)(Liquid us)	+217°C
	-Temperature(t_L)	60-150 secs.
Peak Temp (T_P)		+260(+0/-5)°C
Time within 5°C of actual Peak Temp (t_p)		30 secs. Max
Ramp-down Rate		6°C/sec. Max
Time 25°C to Peak Temp (T_P)		8 min. Max
Do not exceed		+260°C



Package Dimensions & Suggested Pad Layout

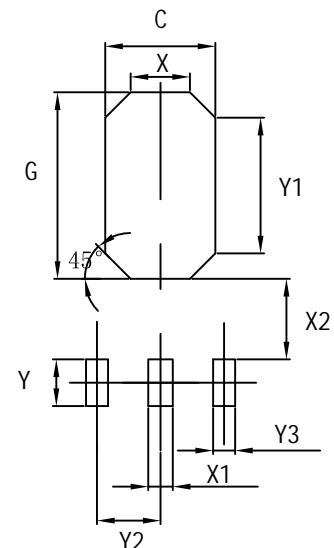
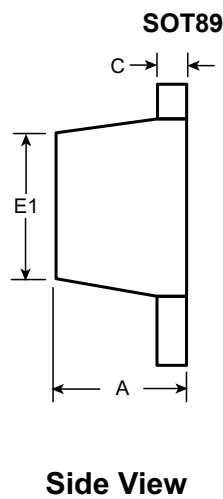
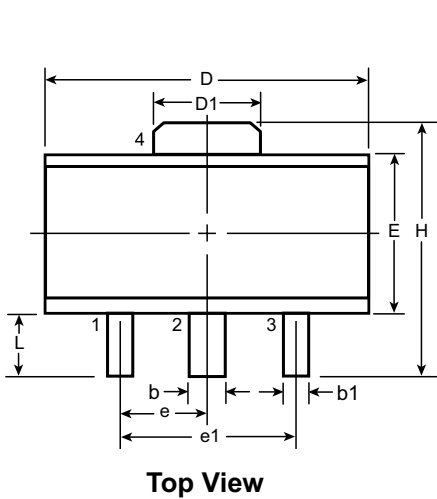

Symbol	A	b	b1	C	D	D1	E	E1	e	e1	H	L		
Dimensions (mm)	MIN	1.40	0.44	0.36	0.3	4.40	1.50	2.29	2.00 [†]	1.50 BSC	3.00 BSC	3.94	0.89	
	NOM	-	-	-	-	-	-	-	-			-	-	-
	MAX	1.60	0.56	0.48	0.5	4.60	1.75	2.60	2.29			-	-	4.25

Dimensions	Value (in mm)
C	2.50
G	3.60
X	1.40
X1	0.90
X2	0.90
Y	1.40
Y1	2.60
Y2	1.50
Y3	0.90

Tape & reel specification

Tape		Symbol	Dimension (mm)
		P0	4.00±0.20
		P1	8.00±0.20
		P2	2.00±0.20
		D0	1.60±0.20
		D1	1.60±0.20
		E	1.75±0.20
		F	7.50±0.15
		W	16.00±0.20
		A0	6.30±0.20
		B0	8.25±0.20
		K0	2.60±0.20
		T	0.23±0.10
		D2	180.0±5.0
		D3	60Min.
D4	R32.0±2.0		
G	R86.5±2.0		
H	R30.0±2.0		
I	13.0±2.0		
W1	13.20±2.0		
W2	16.50±2.0		
Quantity: 1000PCS			

13" Reel

