

Features

- Low collector-emitter saturation voltage
- High collector current capability: I_C and I_{CM}
- High collector current gain (h_{FE}) at high I_C
- Higher efficiency leading to less heat generation
- Complement to PBSS4350

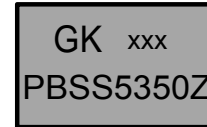

LOGO GK XXX CODE

Application

- Power management
 - DC/DC converters
 - Supply line switching
 - Battery charger
 - Linear voltage regulation (LDO).
- Peripheral drivers
 - Driver in low supply voltage applications, e.g. lamps, LEDs
 - Inductive load driver, e.g. relays, buzzers, motors.

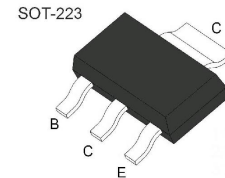

MAXIMUM RATINGS AND ELECTRICAL CHARACTERISTICS

Absolute Maximum Ratings $T_a = 25^\circ\text{C}$

Parameter	Symbol	Value	Unit
Collector-Base Voltage	BV_{CBO}	-60	V
Collector-Emitter Voltage	BV_{CEO}	-50	V
Emitter-Base Voltage	BV_{EBO}	-6	V
Collector Current(DC)	I_C	-3	A
Peak collector current Current	I_{CM}	-5	A
Collector Power Dissipation	P_C	1.35	W
Junction Temperature	T_j	150	$^\circ\text{C}$
Storage Temperature	T_{stg}	-55~150	$^\circ\text{C}$

ELECTRICAL CHARACTERISTICS (TA = 25°C unless otherwise noted.)

Parameter	Symbol	Conditions	Value			Unit
			Min	Typ	Max	
Collector-base breakdown voltage	BV_{CBO}	$I_C = -100\mu A, I_E = 0$	-60			V
Collector-emitter breakdown voltage	BV_{CEO}	$I_C = -1mA, I_B = 0$	-50			V
Emitter-base breakdown voltage	BV_{EBO}	$I_E = -100\mu A, I_C = 0$	-6			V
Collector cut-off current	I_{CBO}	$V_{CB} = -50V, I_B = 0$			-100	nA
Emitter cut-off current	I_{EBO}	$V_{EB} = -5V, I_C = 0$			-100	nA
* DC current gain	h_{FE}	$V_{CE} = -2V, I_C = -500mA$ $V_{CE} = -2V, I_C = -1A$ $V_{CE} = -2V, I_C = -2A$	200 200 100			
* Collector-emitter saturation voltage	$V_{CE(sat)}$	$I_C = -500mA, I_B = -50mA$			-100	mV
		$I_C = -1A, I_B = -50mA$			-180	mV
		$I_C = -2A, I_B = -200mA$			-300	mV
* Equivalent on-resistance	R_{CEsat}	$I_C = -2A, I_B = -200mA$			150	mΩ
* Base-emitter saturation voltage	$V_{BE(sat)}$	$I_C = -2A, I_B = -200mA$			-1.3	V
* Base-emitter turn-on voltage	$V_{BE(on)}$	$V_{CE} = -2V, I_C = -1A$			-1.1	V
Transition frequency	f_T	$V_{CE} = -5V, I_C = -100mA$	100			MHz
Collector capacitance	C_C	$V_{CB} = -10V, I_E = I_C = 0, f = 1MHz$			40	pF

* Pulse test: $PW \leq 300\mu s$, duty cycle $\leq 2\%$ Pulse

Thermal Characteristics

Parameter	Symbol	Conditions	Value	Unit
Resistance from junction to ambient in	$R_{\theta JA}$	in free air; notes 1	92	°C/W
		in free air; notes 2	62.5	°C/W

Notes

1. Device mounted on a printed-circuit board; single sided copper; tin plated; mounting pad for collector 1cm²
2. Device mounted on a printed-circuit board; single sided copper; tin plated; mounting pad for collector 6cm²

RATING AND CHARACTERISTIC CURVES

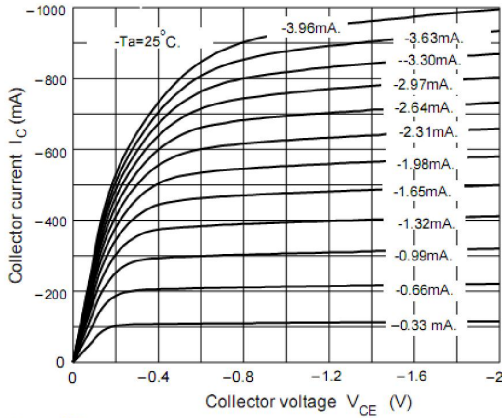

Figure 1. Static Characteristic

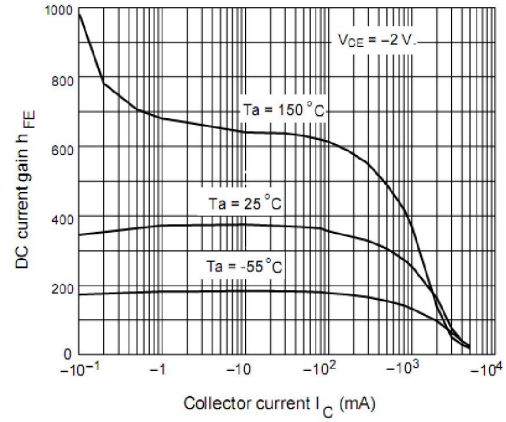

Figure 2. DC current Gain

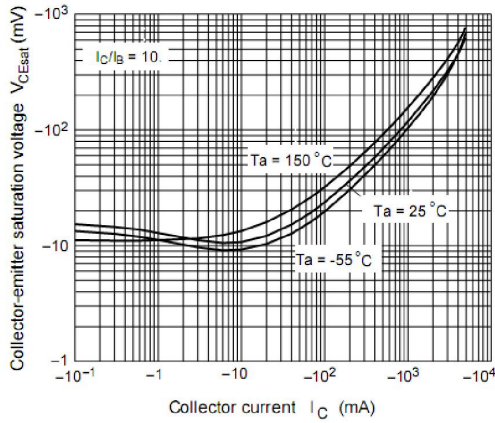

Figure 3. Collector-Emitter Saturation Voltage

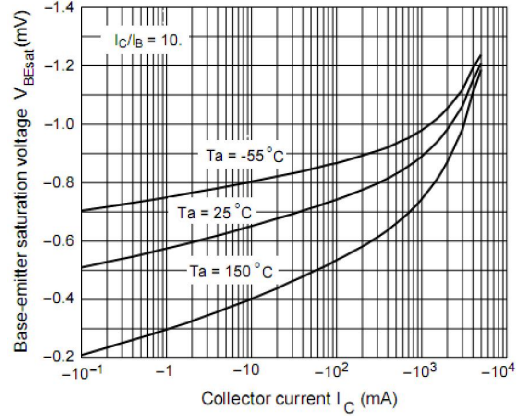

Figure 4. Base-Emitter Saturation Voltage

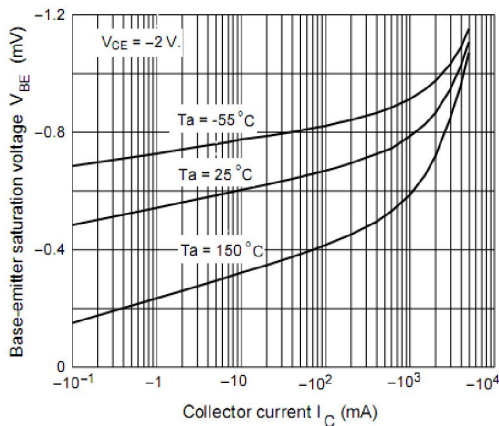

Figure 5. Base-Emitter on Voltage

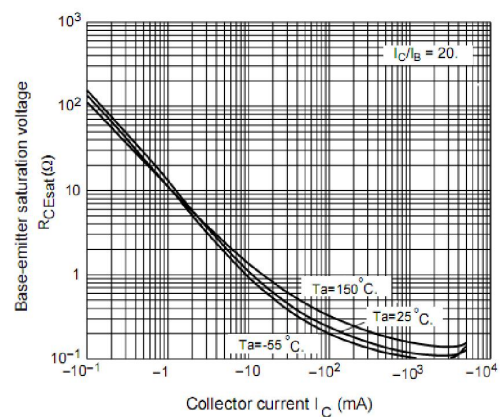

Figure 6. Equivalent on-resistance

Soldering parameters

Reflow Condition		Pb-Free assembly (see as below)
Pre Heat	-Temperature Min ($T_{s(min)}$)	+150 °C
	-Temperature Max($T_{s(max)}$)	+200 °C
	-Time (Min to Max) (ts)	60-180 secs.
Average ramp up rate (Liquid us Temp (T_L) to peak)		3 °C/sec. Max
$T_{s(max)}$ to T_L - Ramp-up Rate		3 °C/sec. Max
Reflow	-Temperature(T_L)(Liquid us)	+217 °C
	-Temperature(t_L)	60-150 secs.
Peak Temp (T_P)		+260(+0/-5) °C
Time within 5 °C of actual Peak Temp (t_p)		30 secs. Max
Ramp-down Rate		6 °C/sec. Max
Time 25 °C to Peak Temp (T_P)		8 min. Max
Do not exceed		+260 °C



Package Dimensions & Suggested Pad Layout

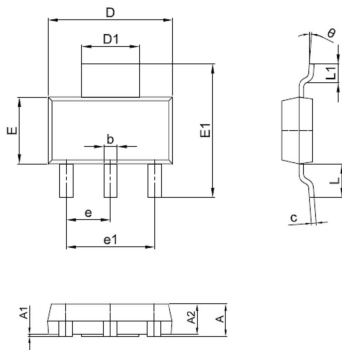

SOT-223

Symbol	Millimeter		Inches	
	Min.	Max.	Min.	Max.
A	1.50	1.80	0.059	0.071
A1	0.00	0.10	0.000	0.004
A2	1.50	1.70	0.059	0.067
b	0.65	0.75	0.026	0.030
c	0.20	0.30	0.008	0.012
D	6.40	6.60	0.252	0.260
D1	2.90	3.10	0.114	0.122
E	3.30	3.70	0.130	0.146
E1	6.85	7.15	0.270	0.281
e	2.20	2.40	0.087	0.094
e1	4.40	4.80	0.173	0.189
L	1.65	1.85	0.065	0.073
L1	0.90	1.15	0.035	0.045

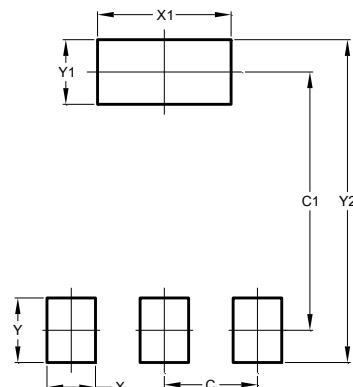

Dimensions	Value (in mm)
C	2.30
C1	6.00
X	1.20
X1	3.60
Y	1.70
Y1	1.70
Y2	7.70

Tape & reel specification

Tape		Symbol	Dimension (mm)
		P0	4.00±0.20
		P1	8.00±0.20
		P2	2.00±0.20
		D0	1.55±0.20
		D1	1.55±0.20
		E	1.75±0.20
		F	5.50±0.20
		W	12.00±0.20
		A0	7.40±0.20
		B0	7.50±0.20
		K0	2.10±0.20
		T	0.20±0.20
		D2	330.0±5.0
		D3	100.0±4.0
W1	18.0±5.0		
W2	22.0±5.0		
l	13.0±2.0		
Quantity: 2500PCS			

13" Reel

