

NSS055N08C



N-Channel Enhanced Shielded Gate Trench Power MOSFET

Voltage:	85 Volts	Current:	120 Ampers	Package:	TO-220C
-----------------	----------	-----------------	------------	-----------------	---------

Features

- NH'S Advanced SGT Technology
- Low Reverse Transfer Capacitances
- Low Gate Charge For Low Switching Loss
- Excellent Qg*Rds(on) Product(FOM)

Typical Applications

- Synchronous Rectification
- High-Frequency Circuits
- The Motor Drives
- Automotive Electronics

Product Summary

VDS Min.@Tj	85	V
Id Min.@Ta	120	A
RDS(ON)(TYP)@10V	4.6	mΩ

Diagram:

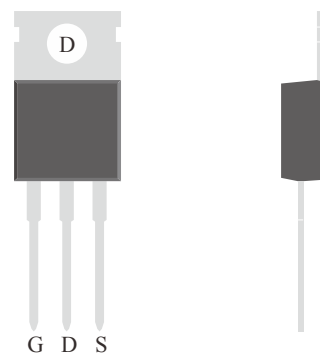

Polarity:

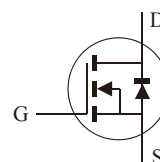

***100% UIS TESTED**

***100% ΔVDS TESTED**

Absolute Maximum Ratings (Ta=25°C Unless Otherwise Specified)

Parameter	Test Conditions	Symbol	Ratings	Unit
Drain-Source Voltage		V _{DS}	85	V
Gate-Source Voltage		V _{GS}	±20	V
Continuous Drain Current (Note 1)	Ta= 25 °C	I _D	120	A
	Ta= 100 °C		77	
Drain Current-Pulse (Note 1)	Tj< 150 °C	I _{DM}	480	A
Maximum Power Dissipation Power	Ta= 25 °C	P _D	174	W
	Ta= 100 °C		69	
Derating Factor		D _F	1.39	W/°C
Avalanche Current,Single Pulse (Note 1)	L= 0.5 mH	I _{AS}	24	A
Single Pulse Avalanche Energy (Note 1) Test Circuit & Waveform See Fig.16	L= 0.5 mH IAS= 24 A, RG= 10.0 Ω Starting Tj=25 °C, VG = 10.0 V	E _{AS}	144	mJ

Thermal Characteristics (Ta=25°C Unless Otherwise Specified)

Parameter	Test Conditions	Symbol	Typ.	Unit
Junction Temperature		T _J	-55 to 150	°C
Storage Temperature Range		T _{STD}	-55 to 150	°C
Thermal Resistance Junction To Ambient With Steady-State	Still Air Environment With Ta=25°C	R _{θJA}	62.0	°C/W
Thermal Resistance Junction-Case With Steady-State	Device Mounted On 75mm x 45mm x 2.5mm Alu. Heat.	R _{θJC}	0.72	

Notes: 1.Pulse Width Limited By Max. Junction Temperature. (See Fig. 13).

NSS055N08C

N-Channel Enhanced Shielded Gate Trench Power MOSFET
Electrical Characteristics (Ta=25°C Unless Otherwise Specified)

Parameter	Test Conditions	Symbol	Min.	Typ.	Max.	Unit
Static Off Characteristics						
Drain-Source Breakdown Voltage	VGS=0V, ID=250uA	BV _{DSS}	85	--	--	V
Bvdss Temperature Coefficient	ID=250uA, Reference 25°C	ΔBV _{DSS} /ΔT _J	--	0.10	--	V/°C
Drain-Source Leakage Current	VDS= 85 V, VGS=0V	I _{DSS}	--	--	1	uA
Gate-Body Leakage Current	VGS= ±20 V, VDS=0V	I _{GSS}	--	--	±100	nA
Forward Transconductance	ID= 20.0 A, VDS= 5 V	g _{fs}	--	85.0	--	S
Static On Characteristics						
Gate Threshold Voltage	VGS= VDS ID=250uA	V _{GS(TH)}	2.0	3.0	4.0	V
Drain-Source On Resistance	ID= 20.0 A, VGS= 10.0 V	R _{DS(ON)}	--	4.6	5.5	mΩ
	ID= 20.0 A, VGS= 4.5 V		--	6.0	8.3	
Dynamic Characteristics						
Gate Resistance	VGS=0V, VDS=0V, Freq.=1MHz	R _g	--	3.3	--	Ω
Input Capacitance	VDS= 42.5 V	C _{iss}	--	3100.0	--	pF
Output Capacitance	VGS= 0 V	C _{oss}	--	1060.0	--	pF
Reverse Transfer Capacitance	F= 1 MHZ	C _{rss}	--	25.0	--	pF
Switching Paramters (Test Circuit & Waveform See Fig.14)						
Turn-On Delay Time	VDS= 42.5 V	t _{d(on)}	--	20.0	--	ns
Turn-On Rise Time	VGS= 10.0 V	t _r	--	39.0	--	ns
Turn-Off Delay Time	RG= 10.0 Ω	t _{d(off)}	--	45.0	--	ns
Turn-Off Rise Time		t _f	--	23.0	--	ns
Gate Charge Paramters (Test Circuit & Waveform See Fig.15)						
Total Gate Charge	VDS= 42.5 V	Q _g	--	55.0	--	nC
Gate-Source Charge	VGS= 10.0 V	Q _{gs}	--	15.0	--	nC
Gate-Drain Charge	ID= 20.0 A	Q _{gd}	--	13.0	--	nC
Drain-Source Diode Characteristics And Maximum Ratings (Test Circuit & Waveform See Fig.17)						
Max. Diode Forward Cuurent		I _S	--	--	120.0	A
Max. Pulsed Forward Cuurent		I _{SM}	--	--	480.0	A
Diode Forward Voltage	ID= 20.0 A, VGS=0V	V _{SD}	--	0.67	1.21	V
Reverse Recovery Time	IS= 20.0 A, di/dt= 100 A/us	t _{rr}	--	60.0	--	ns
Reverse Recovery Charge	VGS= 0.0 V	Q _{rr}	--	560.0	--	nC
Reverse Recovery Current		I _{RRM}	--	18.7	--	A

N-Channel Enhanced Shielded Gate Trench Power MOSFET

Typical Characteristics Curves

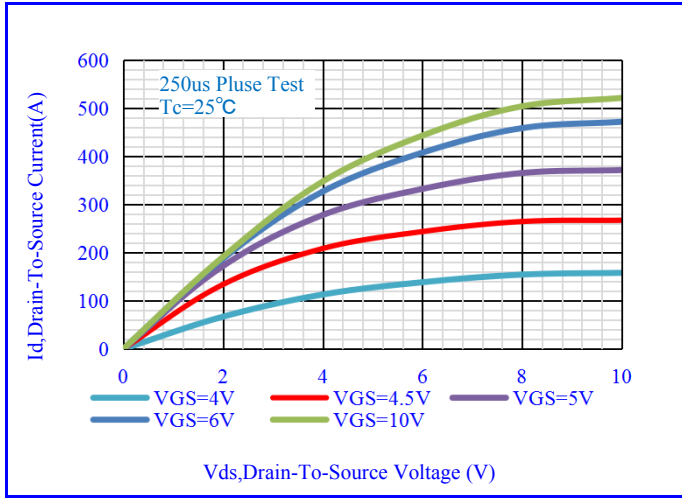

Fig.1-Output Characteristics

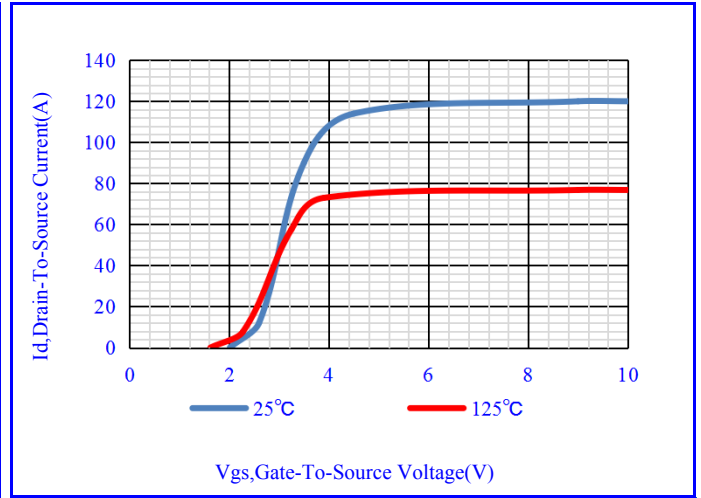

Fig.2-Transfer Characteristics

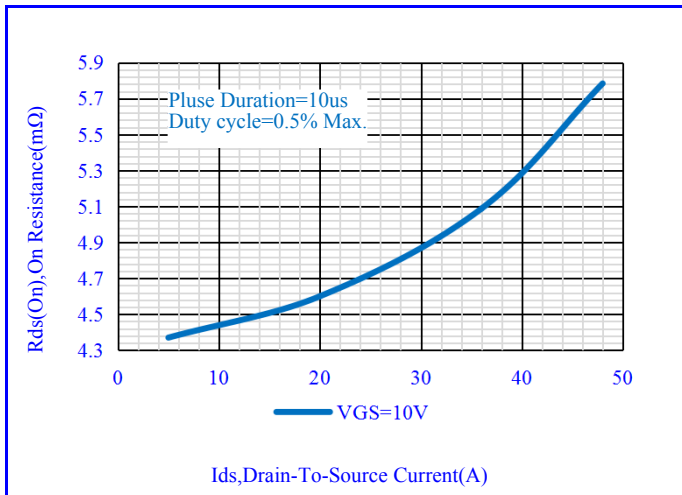

Fig.3-On Resistance Vs. Drain Current

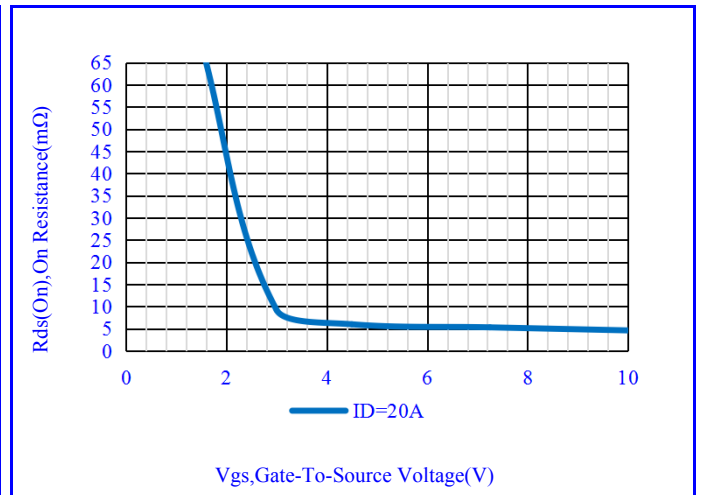

Fig.4-On Resistance Vs. Gate Source Voltage

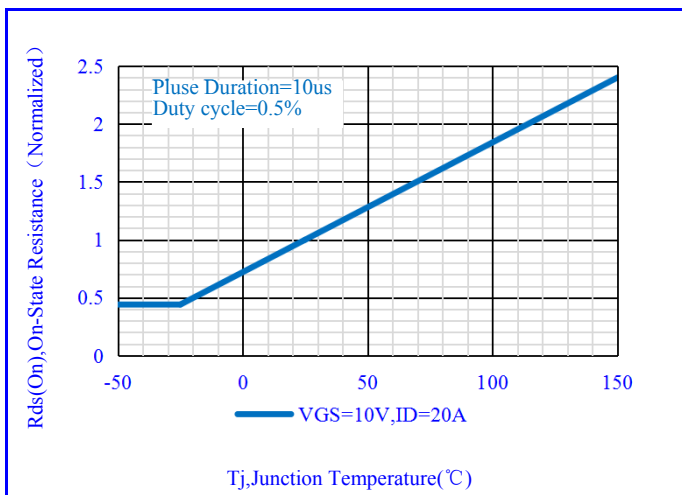

Fig.5-On Resistance Vs. Junction Temperature

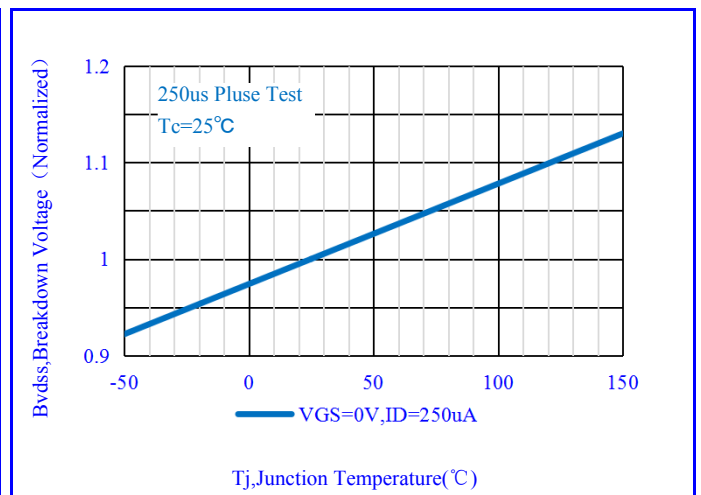

Fig.6-Breakdown Voltage Vs. Junction Temperature

NSS055N08C



N-Channel Enhanced Shielded Gate Trench Power MOSFET

Typical Characteristics Curves

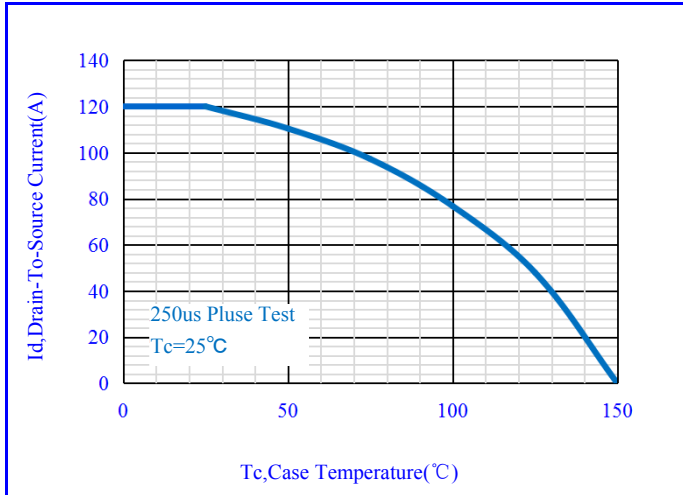

Fig.7-Maximum Continuous Drain Current Vs. Case Temperature

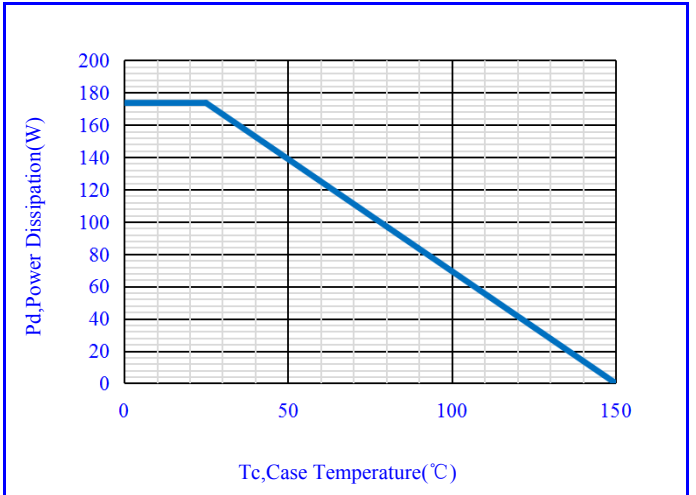

Fig.8-Maximum Power Dissipation Vs. Case Temperature

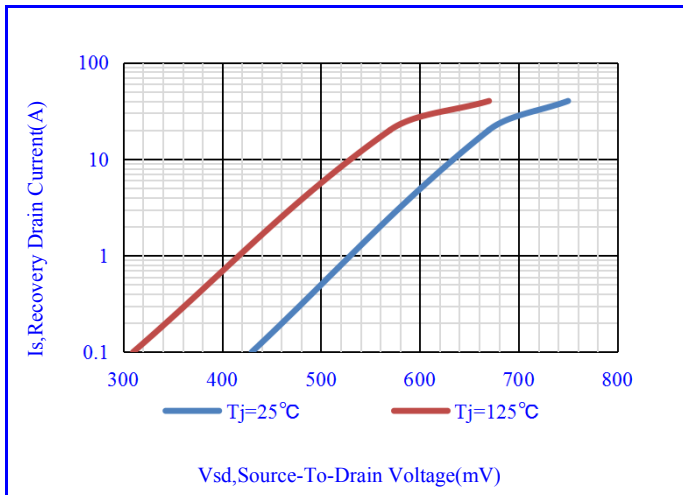

Fig.9-Source-To-Drain Diode Forward Voltage

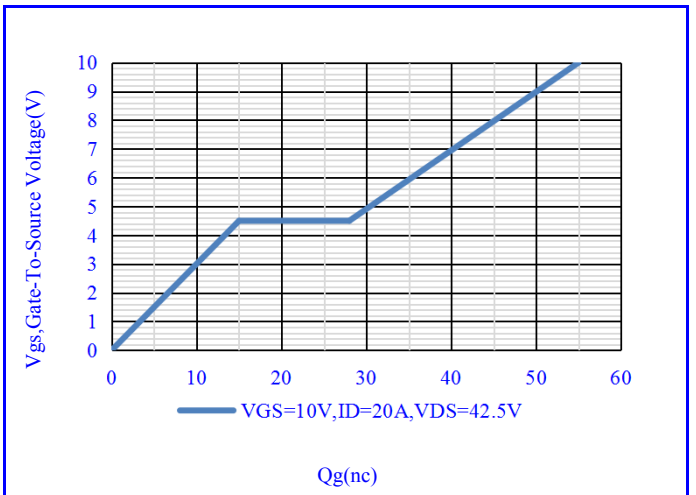

Fig.10-Gate Charge Waveform

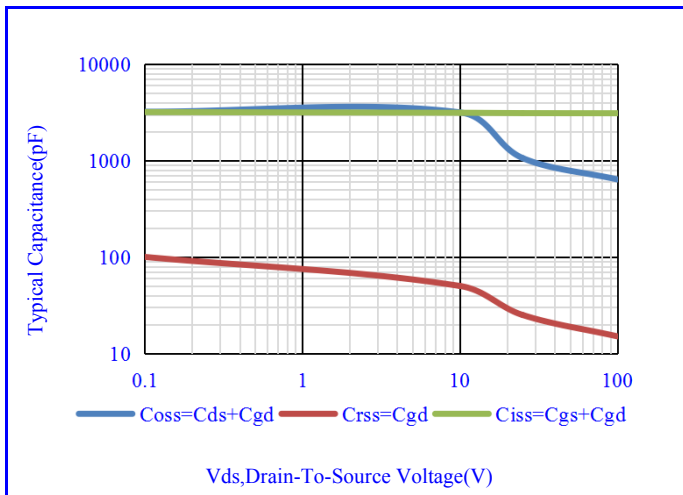

Fig.11-Typical Capacitance Vs. Drain-To-Source Voltage

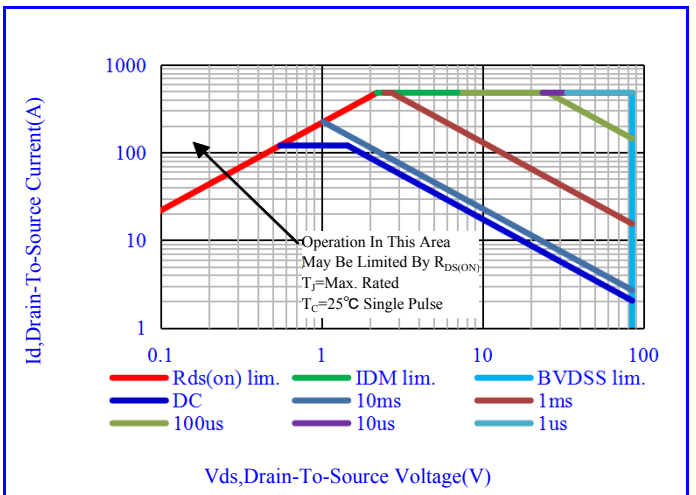

Fig.12-Maximum Safe Operating Area(SOA)

NSS055N08C



N-Channel Enhanced Shielded Gate Trench Power MOSFET

Typical Characteristics Curves

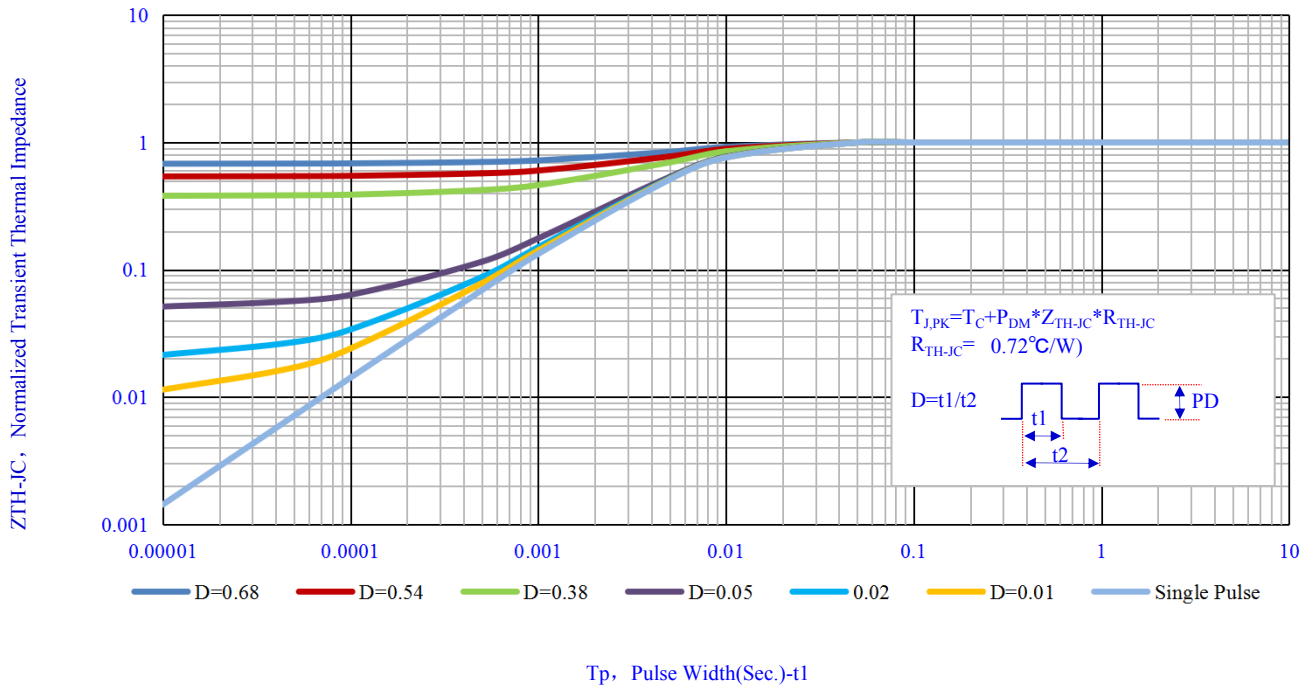

Fig.13- Normalized Maximum Transient Thermal Impedance Vs.Pulse Width

Test Circuit & Waveform

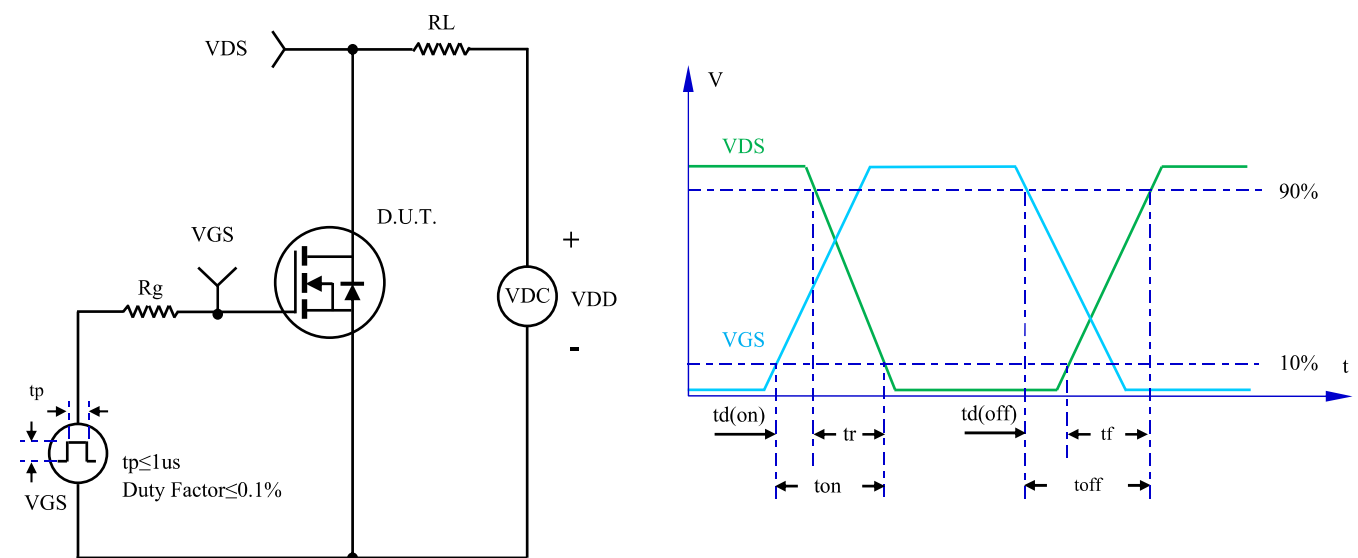

Fig.14- Resistive Switching Test Circuit & Waveform

NSS055N08C



N-Channel Enhanced Shielded Gate Trench Power MOSFET

Test Circuit & Waveform

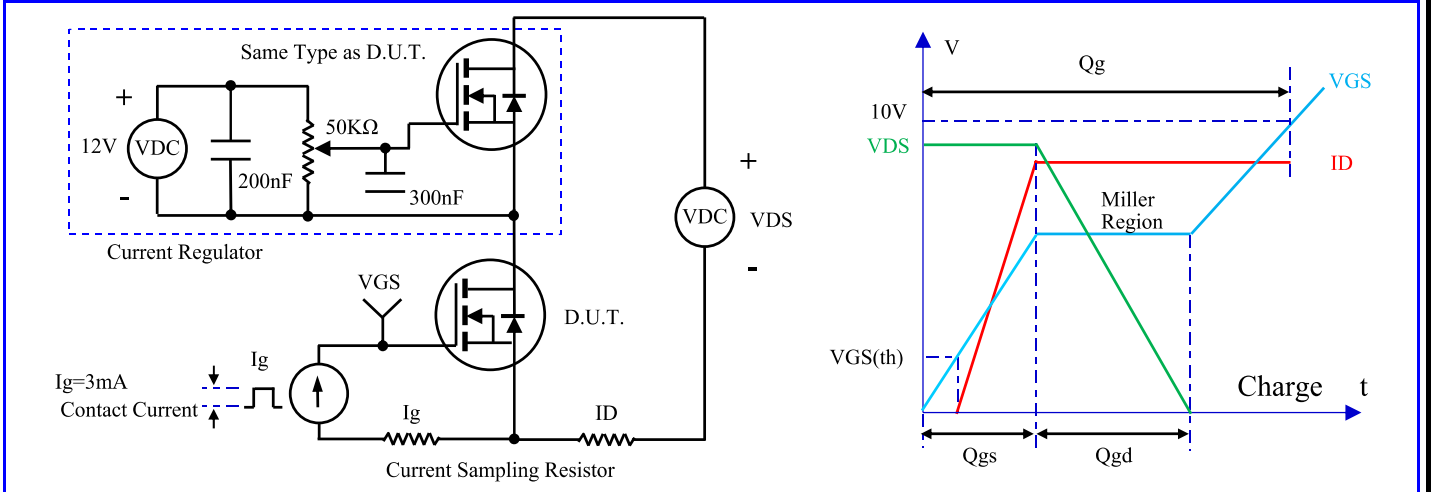

Fig.15-Gate Charge Test Circuit & Waveform

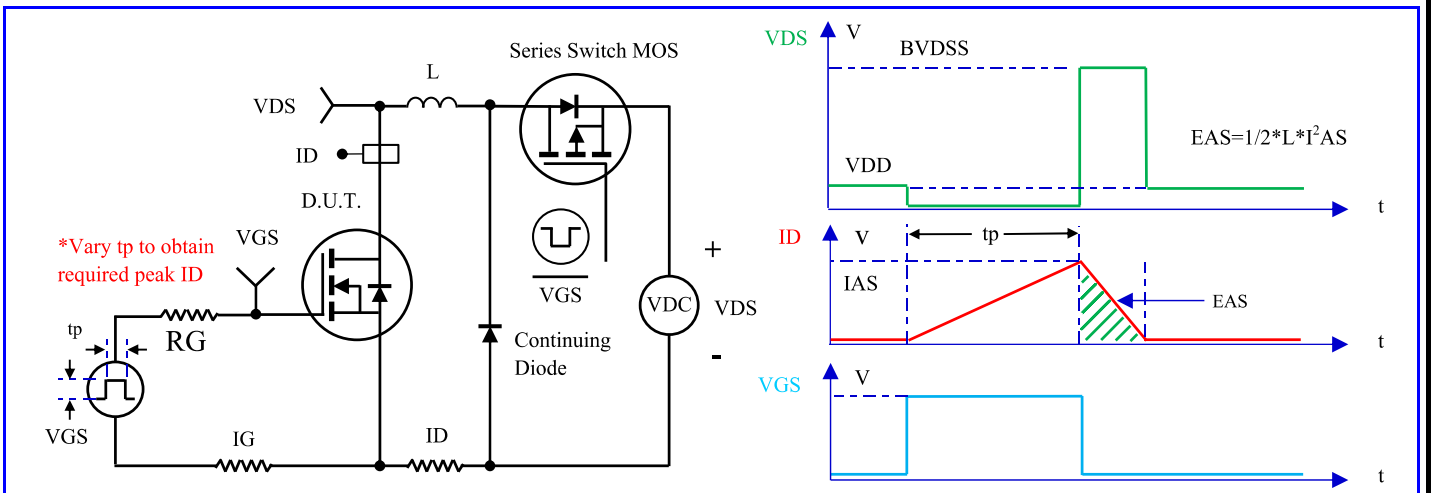

Fig.16- Unclamped Inductive Switching (UIS) Test Circuit & Waveform

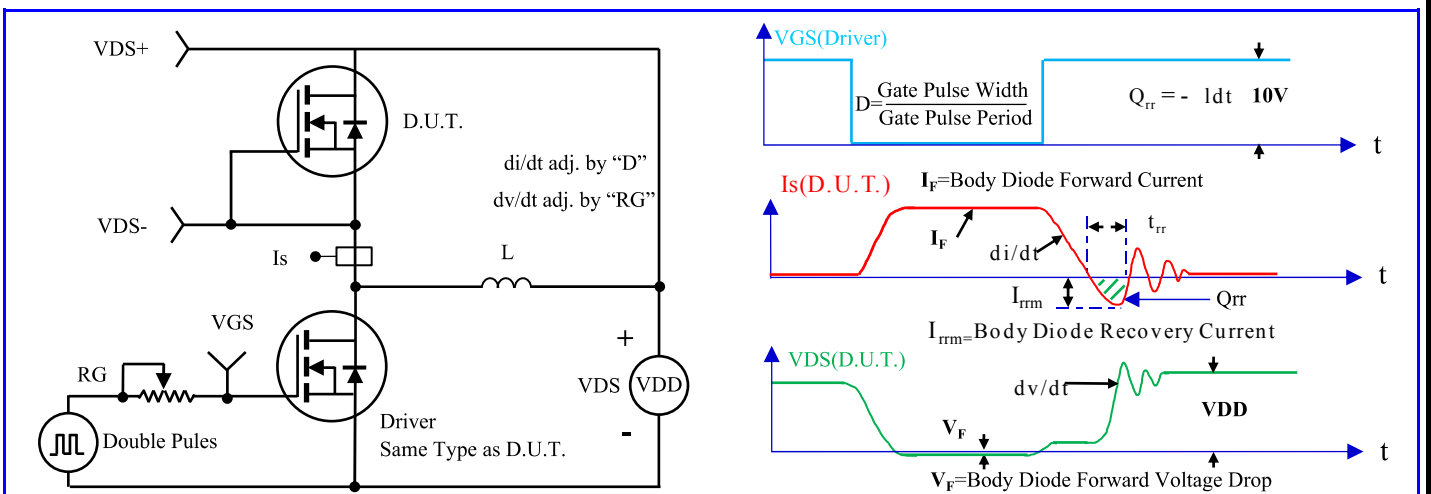

Fig.17- Diode Recovery Test Circuit & Waveform

NSS055N08C



N-Channel Enhanced Shielded Gate Trench Power MOSFET

OUTLINE DRAWINGS		TO-220C					
		OUTLINE DIMENSIONS					
		Dim.	Millimeters			Inches	
Min.	Typ.		Max.	Min.	Typ.	Max.	
A	9.25	-	10.75	0.3642	-	0.4232	
B	4.15	-	4.95	0.1634	-	0.1949	
C	1.10	-	1.65	0.0433	-	0.0650	
D	0.25	-	0.65	0.0098	-	0.0256	
E	14.50	-	16.70	0.5709	-	0.6575	
F	8.40	-	9.95	0.3307	-	0.3917	
L	12.15	-	14.30	0.4783	-	0.5630	
H	3.00	-	3.80	0.1181	-	0.1496	
J	1.05	-	1.60	0.0413	-	0.0630	
K	0.65	-	0.95	0.0256	-	0.0374	
M	2.10	-	2.90	0.0827	-	0.1142	
O	3.20	-	4.10	0.1260	-	0.1614	
P	2.45	-	3.10	0.0965	-	0.1220	

RECOMMENDED LAYOUT DRAWINGS		TO-220C					
		OUTLINE DIMENSIONS					
		Dim.	Millimeters			Inches	
Min.	Typ.		Max.	Min.	Typ.	Max.	
A	-	1.60	-	-	0.0630	-	
B	-	1.60	-	-	0.0630	-	
C	-	2.54	-	-	0.1000	-	
D	-	1.00	-	-	0.0394	-	

NSS055N08C



N-Channel Enhanced Shielded Gate Trench Power MOSFET

MARKING INFORMATION

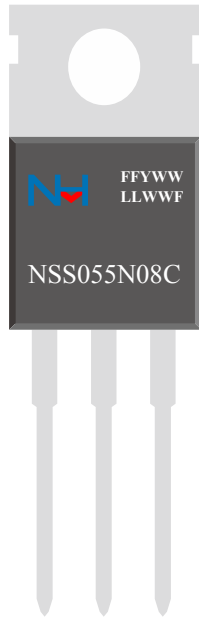

MARKING INSTRUCTIONS

NH=Niuhan Trademark
 FF=Product Line Code,According To Actual Changes
 YWW=Date Code,According To Actual Changes
 LLWWF=Internal Code,According To Actual Changes
 NSS055N08C=Model

PACKING INFORMATION

Package Type	Package Code	Product Weight Approx(g/Pcs)	Package Method	Quantity (Pcs/Min. Pack.)	Quantity (Pcs/Inner Box)	Quantity (Pcs/Carton)
TO-220C	P1	2.057	Tube	50	1000	5000

NSS055N08C



N-Channel Enhanced Shielded Gate Trench Power MOSFET

Recommended wave soldering condition

Product	Peak Temperature	Soldering Time
Pb-free devices	260 +0/-5 °C	5 +1/-1 seconds

Recommended temperature profile for IR reflow

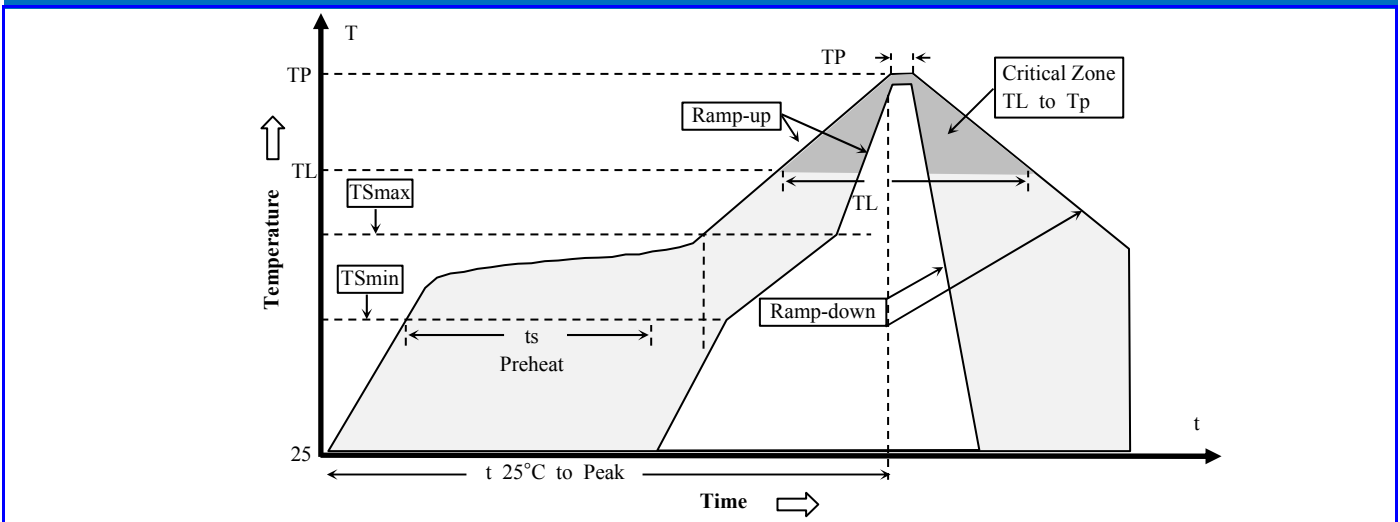

Profile feature	Sn-Pb eutectic Assembly	Pb-free Assembly
Average ramp-up rate (T _{smax} to T _p)	3°C/second max.	3°C/second max.
Preheat -Temperature Min(T _{S min}) -Temperature Max(T _{S max}) -Time(t _{s min} to t _{s max})	100°C 150°C 60-120 seconds	150°C 200°C 60-180 seconds
Time maintained above: -Temperature (T _L) - Time (t _L)	183°C 60-150 seconds	217°C 60-150 seconds
Peak Temperature(T _p)	240 +0/-5 °C	260 +0/-5 °C
Time within 5°C of actual peak temperature(t _p)	10-30 seconds	20-40 seconds
Ramp down rate	6°C/second max.	6°C/second max.
Time 25 °C to peak temperature	6 minutes max.	8 minutes max.

Note : All temperatures refer to topside of the package, measured on the package body surface.

NSS055N08C



N-Channel Enhanced Shielded Gate Trench Power MOSFET

Disclaimer

- Reproducing and modifying information of the document is prohibited without permission from Nihang Electronics Technology Co., LTD
- Nihang Electronics Technology Co., LTD. reserves the rights to make changes of the content herein the document anytime without notification.
- Nihang Electronics Technology Co., LTD. disclaims any and all liability arising out of the application or use of any product including damages incidentally and consequentially occurred.
- Nihang Electronics Technology Co., LTD. does not assume any and all implied warranties, including warranties of fitness for particular purpose, non-infringement and merchantability.
- Applications shown on the herein document are examples of standard use and operation. Customers are responsible in comprehending the suitable use in particular applications. Nihang Electronics Technology Co., LTD. makes no representation or warranty that such applications will be suitable for the specified use without further testing or modification.
- The products shown herein are not designed and authorized for equipments requiring high level of reliability or relating to human life and for any applications concerning life-saving or life-sustaining, such as medical instruments, transportation equipment, aerospace machinery et cetera. Customers using or selling these products for use in such applications do so at their own risk and agree to fully indemnify Nihang Electronics Technology Co., LTD. for any damages resulting from such improper use or sale.
- When the appearance of the product and chip size does not change, in order to product the customer. quality, change the internal structure and the production process Nihang can not notify