

# Low Power, Wide Input Range, Unity-Gain Difference Amplifiers

## Features

- High Reliability:
  - Input Protection to  $\pm 65$  V (power on & off)
  - Over Temperature Protection
- CMRR: 104 dB min
- CMRR Temperature Drift: 0.2 ppm/ $^{\circ}$ C max
- High Precision:
  - Input Offset Voltage: 100  $\mu$ V max
  - Input Offset Drift: 0.5  $\mu$ V/ $^{\circ}$ C
  - Low Input Bias Current: 5 pA
  - Gain Error: 15 ppm max
  - Gain Error Temperature Drift: 0.3 ppm/ $^{\circ}$ C max
- Wide Input Rang: 2 times of Supplies
- Bandwidth: 500 kHz
- Supply Current: 330  $\mu$ A per channel
- Wide Power Supply Range: 2.7 V to 36 V
- Specified Temperature Range: -40  $^{\circ}$ C to +125  $^{\circ}$ C

## Applications

- Li-Ion Battery Formation & Grading
- Precision Data Acquisition
- Communication Systems
- Sensor Signal Conditioning
- Industrial Control

## Application Examples

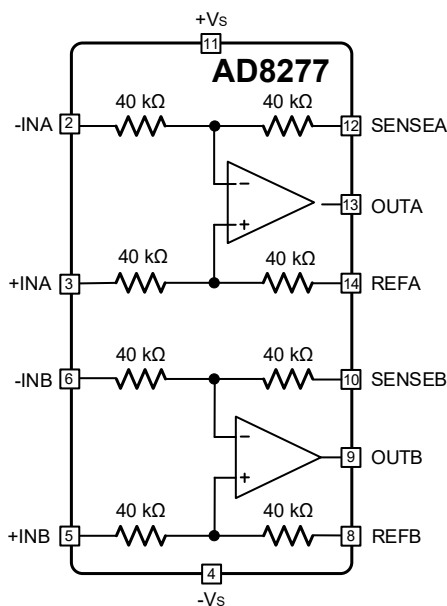

Figure 1. AD8277

## AD8276 Product Family

Product	Gain	Number of Channels	Package
AD8276	1	1	SOIC/MSOP-8
AD8277	1	2	SOIC-14
AD8278	0.5, 2	1	SOIC/MSOP-8
AD8279	0.5, 2	2	SOIC-14

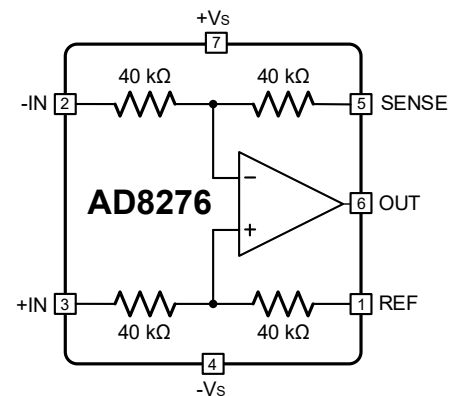

Figure 2. AD8276

## Pin Configurations and Function Descriptions

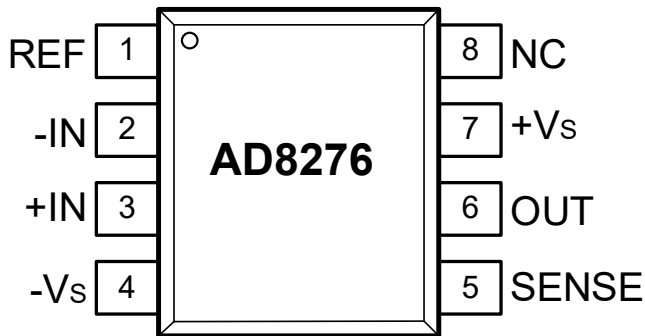

Figure 3. AD8276 Pin Configuration (8-lead SOIC)

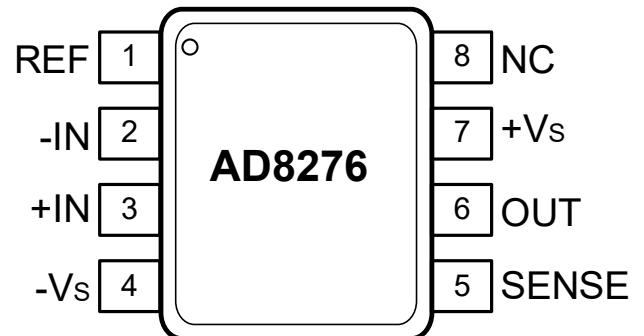

Figure 4. AD8276 Pin Configuration (8-lead MSOP)

Mnemonic	Pin No.	I/O <sup>1</sup>	Description
REF	1	AI	Reference voltage input
-IN	2	AI	Inverting input
+IN	3	AI	Non-inverting input
-Vs	4	P	Negative power supply
SENSE	5	AI	Sense terminal
OUT	6	AO	Output
+Vs	7	P	Positive power supply
NC	8	--	No Connect. This pin is not internally connected

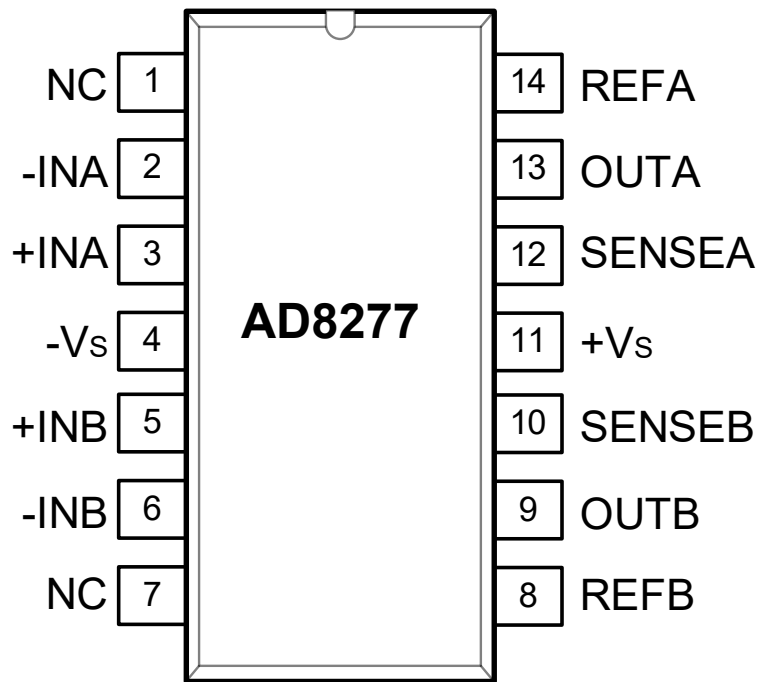

Figure 5. AD8277 Pin Configuration (14-lead SOIC)

Mnemonic	Pin No.	I/O <sup>1</sup>	Description
NC	1	--	No Connect. This pin is not internally connected
-INA	2	AI	Channel A inverting input
+INA	3	AI	Channel A non-inverting input
-Vs	4	P	Negative power supply
+INB	5	AI	Channel B non-inverting input
-INB	6	AI	Channel B inverting input
NC	7	--	No Connect. This pin is not internally connected
REFB	8	AI	Channel B reference voltage input
OUTB	9	AO	Channel B output
SENSEB	10	AI	Channel B sense terminal
+Vs	11	P	Positive power supply
SENSEA	12	AI	Channel A sense terminal
OUTA	13	AO	Channel A output
REFA	14	AI	Channel A reference input

## Absolute Maximum Ratings

Parameter	Rating
Supply Voltage	40 V
Maximum Voltage at Any Input Pin	$(-V_S) + 65 \text{ V}$
Minimum Voltage at Any Input Pin	$(-V_S) - 65 \text{ V}$
Output Short-Circuit Duration to GND <sup>2</sup>	Continuous
Operating Temperature Range	-40 °C to 125 °C
Storage Temperature Range	-65 °C to 150 °C
Junction Temperature Range	-65 °C to 150 °C
Maximum Reflow Temperature	260 °C
Lead Temperature, Soldering (10 sec)	300 °C
Electrostatic Discharge (ESD)	
Human Body Model (HBM)	3.5 kV
Charged Device Model (CDM)	2 kV

## Thermal Resistance

Package Type	$\theta_{JA}$	$\theta_{JC}$	Unit
SOIC-8	158	43	°C/W
MSOP-8	190	44	°C/W
SOIC-14	120	36	°C/W

## Specifications

The ● denotes the specification which apply over the specified temperature range, otherwise specifications are at  $T_A = 25\text{ °C}$ ,  $V_S = \pm 15\text{ V}$ ,  $V_{REF} = 0\text{ V}$ ,  $R_L = 10\text{ k}\Omega$ ,  $G = 1$ , unless otherwise noted.

Parameter	Symbol	Conditions	Min	Typ	Max	Unit
<b>INPUT CHARACTERISTICS</b>						
System Offset <sup>1</sup>	$V_{OS}$	B Grade		15	100	$\mu\text{V}$
		B Grade, $-40\text{ °C}$ to $85\text{ °C}$			200	$\mu\text{V}$
		B Grade	●		300	$\mu\text{V}$
		A Grade		30	150	$\mu\text{V}$
		A Grade, $-40\text{ °C}$ to $85\text{ °C}$			300	$\mu\text{V}$
		A Grade	●		500	$\mu\text{V}$
System Offset Drift	$TCV_{OS}$	B Grade, $-40\text{ °C}$ to $85\text{ °C}$		0.5	2	$\mu\text{V}/\text{°C}$
		B Grade	●		3	$\mu\text{V}/\text{°C}$
		A Grade, $-40\text{ °C}$ to $85\text{ °C}$		1.0	4	$\mu\text{V}/\text{°C}$
		A Grade	●		5	$\mu\text{V}/\text{°C}$
Power Supply	PSRR	$V_S = \pm 2.25\text{ V}$ to $\pm 18\text{ V}$		0.1	0.6	$\mu\text{V}/\text{V}$
		$V_S = \pm 2.25\text{ V}$ to $\pm 18\text{ V}$	●		1.1	$\mu\text{V}/\text{V}$
Common Mode Rejection Ratio	CMRR	$V_S = \pm 15\text{ V}$ , $V_{CM} = \pm 10\text{ V}$ , $R_S = 0\ \Omega$	104	124		dB
			●	96		dB
Common Mode Rejection Ratio Drift			●	0.03	0.2	ppm/°C
Input Operating Voltage Range <sup>2</sup>	IVR		$-2(V_S + 0.1)$		$+2(V_S - 1.5)$	V
<b>Input Impedance<sup>3</sup></b>						
Differential Mode	$R_{IN}$			80		k $\Omega$
Common Mode				40		k $\Omega$
<b>DYNAMIC PERFORMANCE</b>						
Bandwidth				500		kHz
Slew Rate				1.0		V/ $\mu\text{s}$
Settling Time	$t_s$	$C_L = 100\text{ pF}$ , 0 to 10 V step, to 0.01 %		18		$\mu\text{s}$
		$C_L = 100\text{ pF}$ , 0 to 10 V step, to 0.001 %		20		$\mu\text{s}$
Channel Separation		$f = 1\text{ kHz}$		140		dB

**GAIN**

Gain Error				0.0002	0.0015	%
			•		0.0030	%
Gain Drift			•	0.04	0.3	ppm/°C
Gain Nonlinearity		$V_{OUT} = 20 V_{P-P}$			5	ppm

**OUTPUT CHARACTERISTICS**

Output Voltage Swing		$R_L = 10 k\Omega$	•	$(-V_S) + 0.2$	$(+V_S) - 0.2$	V
Short-Circuit Current	$I_{sc}$	Source			28	mA
		Sink			-15	mA
Capacitive Load Drive					200	pF

**NOISE <sup>5</sup>**

Voltage Noise	$e_{n,p-p}$	$f = 0.1 \text{ Hz to } 10 \text{ Hz}$			2.5	$\mu V_{P-P}$
Voltage Noise Density	$e_n$	$f = 1 \text{ kHz}$			65	$nV/\sqrt{Hz}$

**POWER SUPPLY**

Supply Current					330	360	$\mu A$
			•			370	$\mu A$
Operating Voltage Range				$\pm 1.35$		$\pm 18$	V

**TEMPERATURE RANGE**

		Specified Temperature Range		-40		+125	°C
--	--	-----------------------------	--	-----	--	------	----

## Typical Performance Characteristics

Unless otherwise stated,  $T_A = 25\text{ }^\circ\text{C}$ ,  $V_S = \pm 15\text{ V}$ ,  $R_L = 10\text{ k}\Omega$ ,  $G = 1$ .

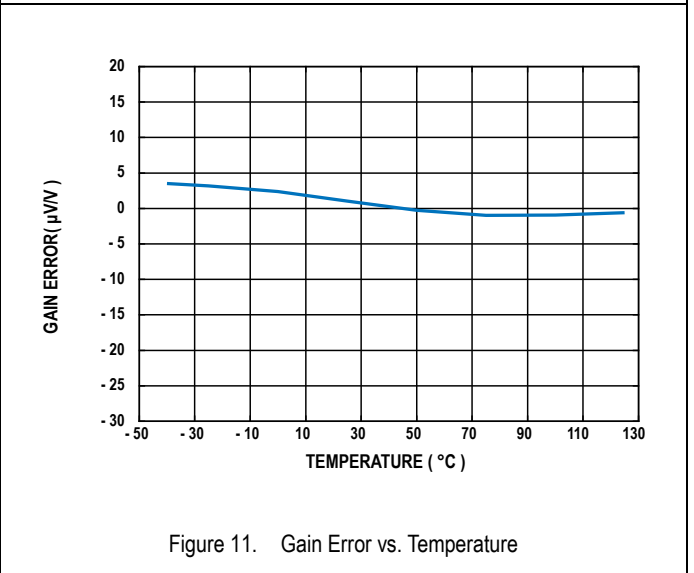
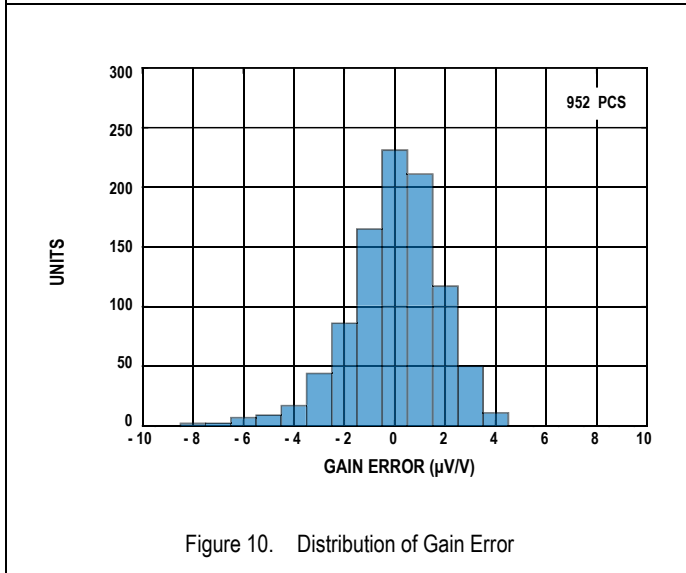
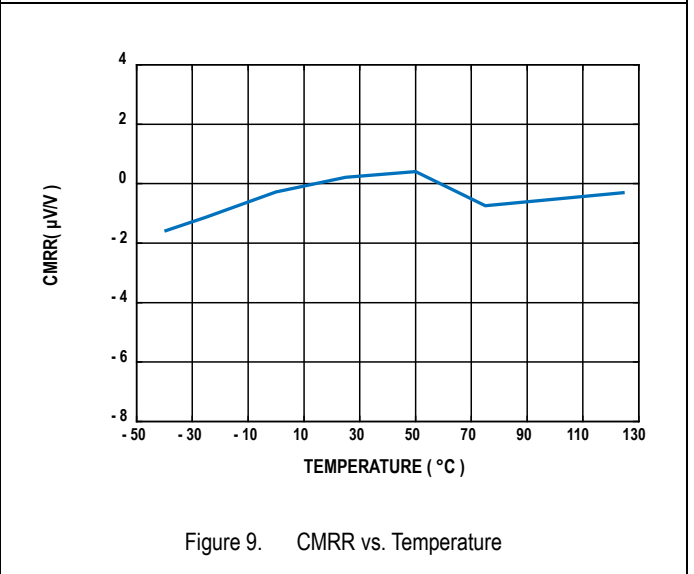
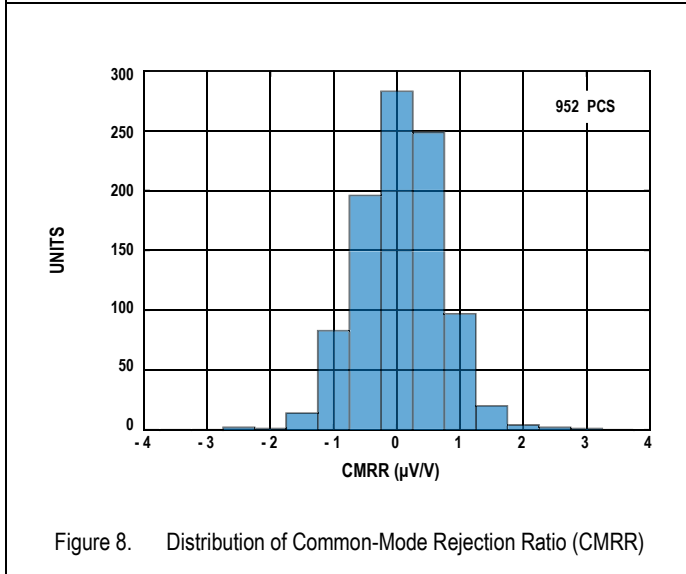
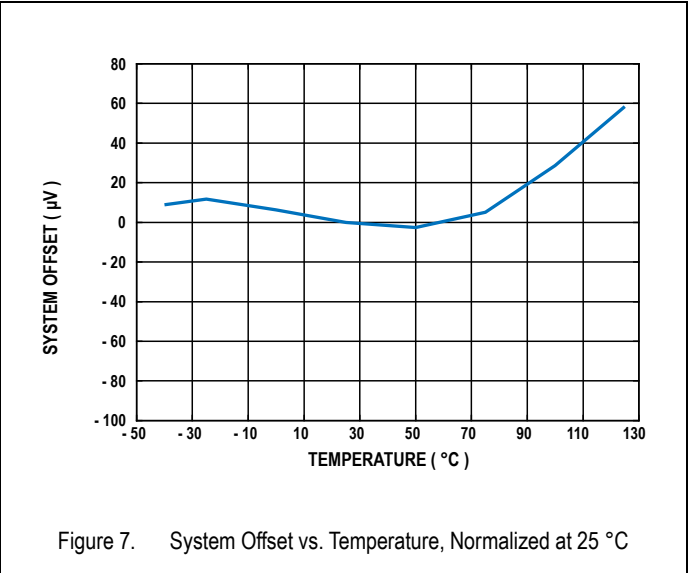
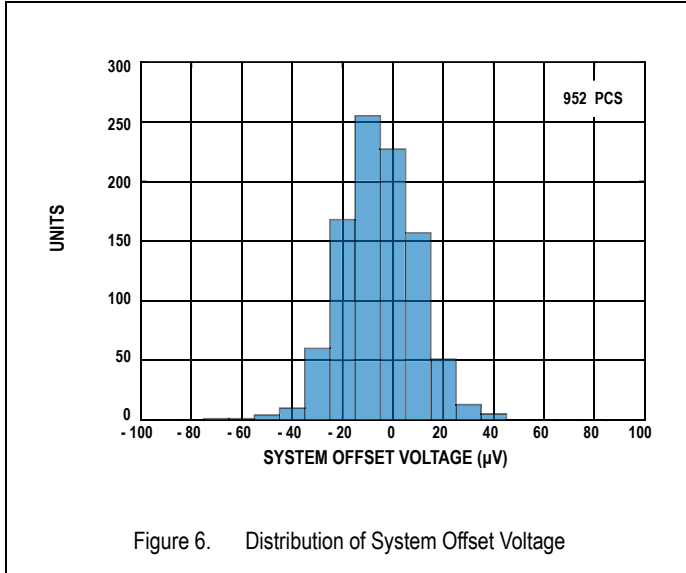

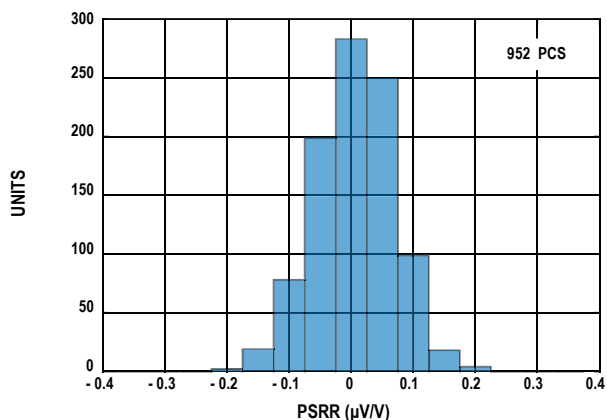

Figure 12. Distribution of PSSR

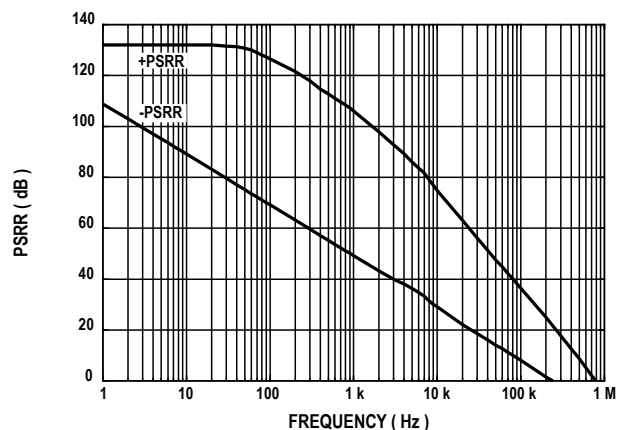

Figure 13. Power Supply Rejection Ratio (PSRR) vs. Frequency

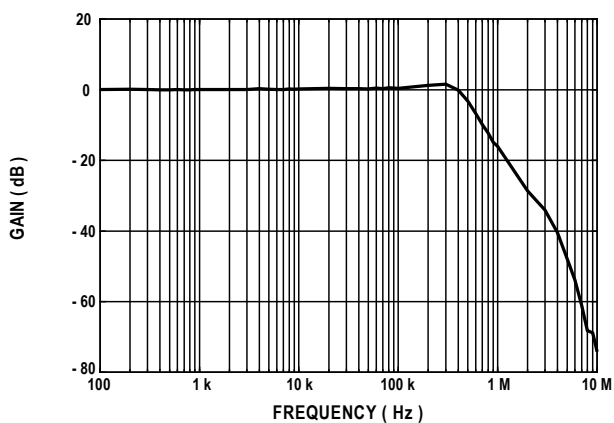

Figure 14. Gain vs. Frequency

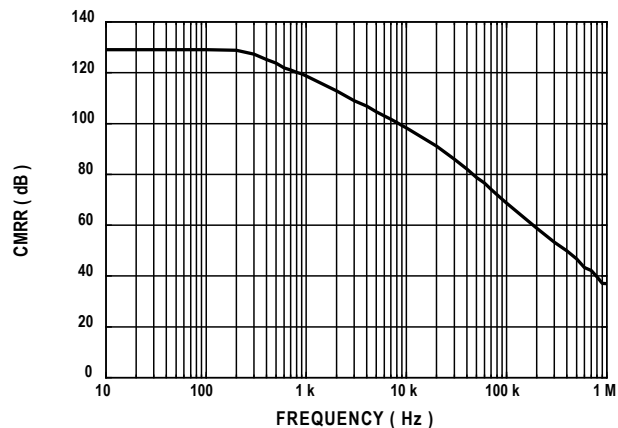

Figure 15. Common Mode Rejection Ratio (CMRR) vs. Frequency

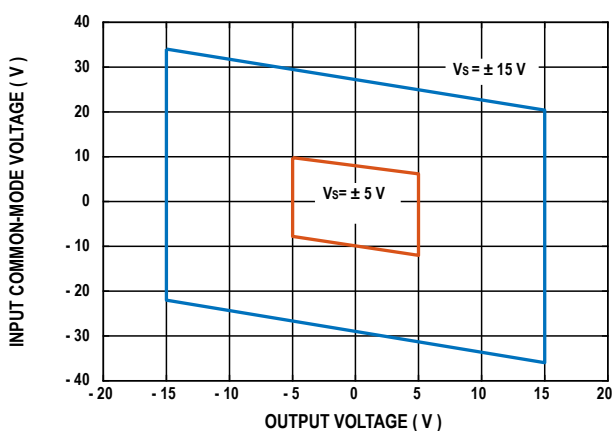

Figure 16. Input Common-Mode Voltage vs. Output Voltage ( $\pm 15$  V and  $\pm 5$  V Supplies)

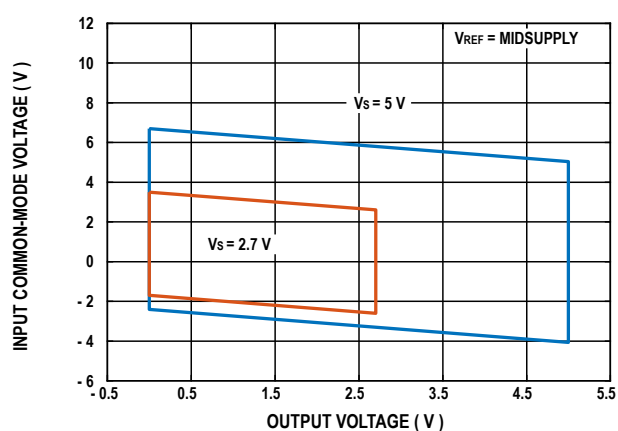

Figure 17. Input Common-Mode Voltage vs. Output Voltage (5 V and 2.7 V Supplies,  $V_{REF} = \text{Midsupply}$ )

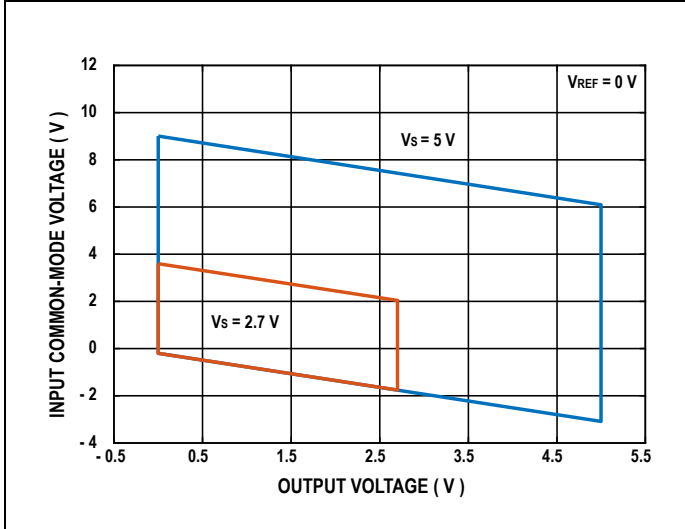

Figure 18. Input Common-Mode Voltage vs. Output Voltage (5 V and 2.7 V Supplies,  $V_{REF} = 0$  V)

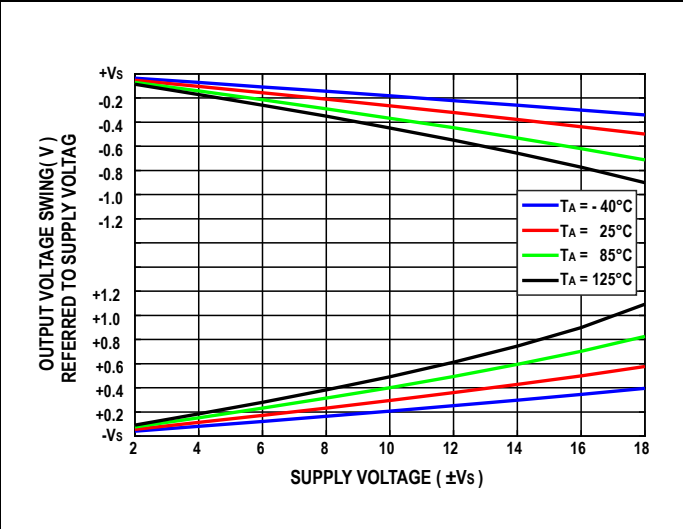

Figure 19. Output Voltage Swing vs. Supply Voltage and Temperature ( $R_L = 2$  k $\Omega$ )

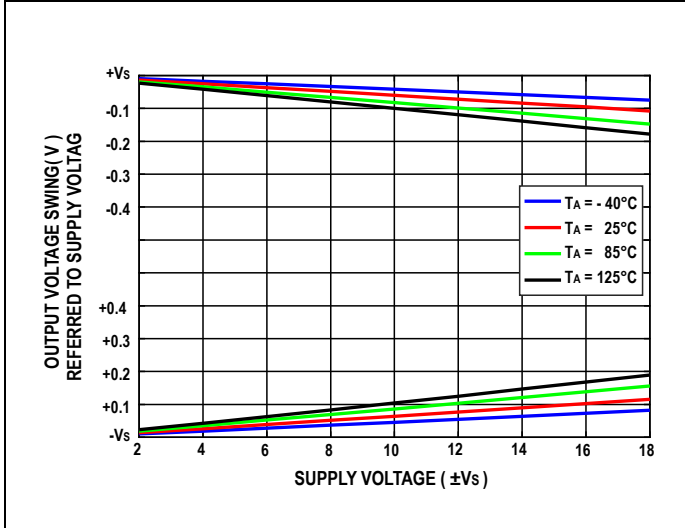

Figure 20. Output Voltage Swing vs. Supply Voltage and Temperature ( $R_L = 10$  k $\Omega$ )

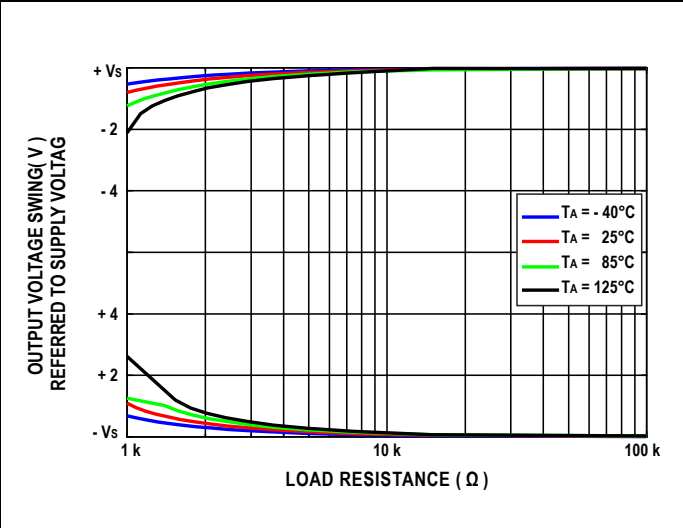

Figure 21. Output Voltage Swing vs. Load Resistance and Temperature ( $V_S = \pm 15$  V)

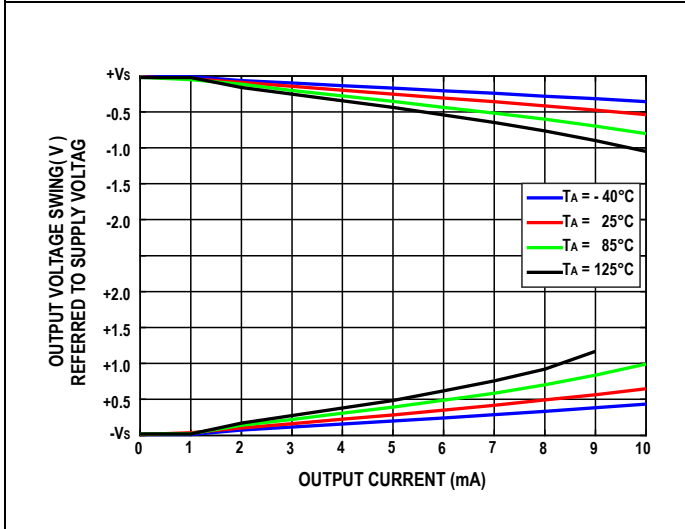

Figure 22. Output Voltage Swing vs. Output Current and Temperature ( $V_S = \pm 15$  V)

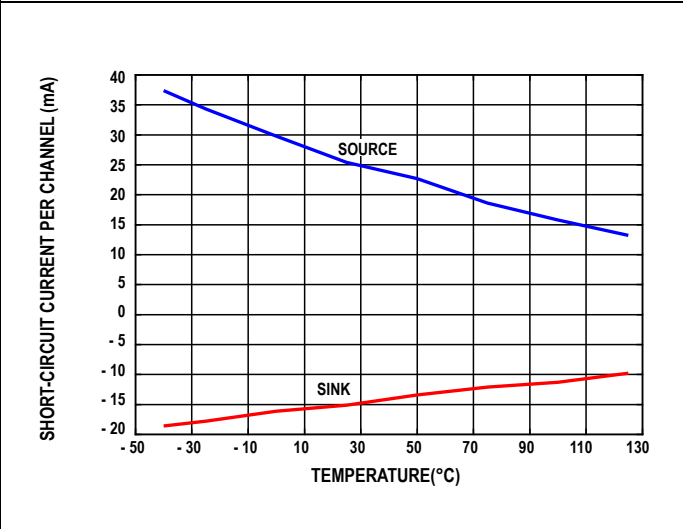

Figure 23. Short-Circuit Current per Channel vs. Temperature

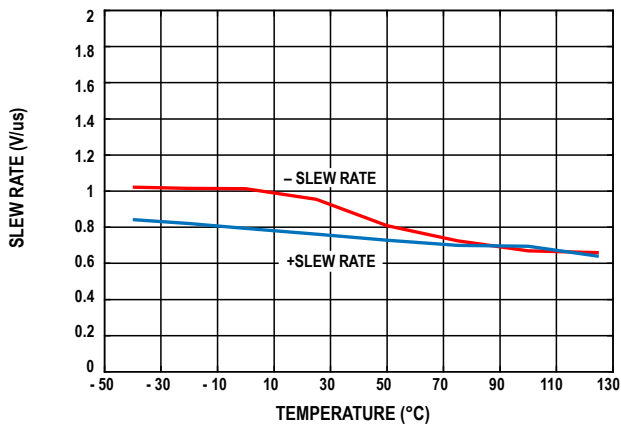

Figure 24. Slew Rate vs. Temperature ( $V_{IN} = 20 V_{P-P}$ , 1 kHz)

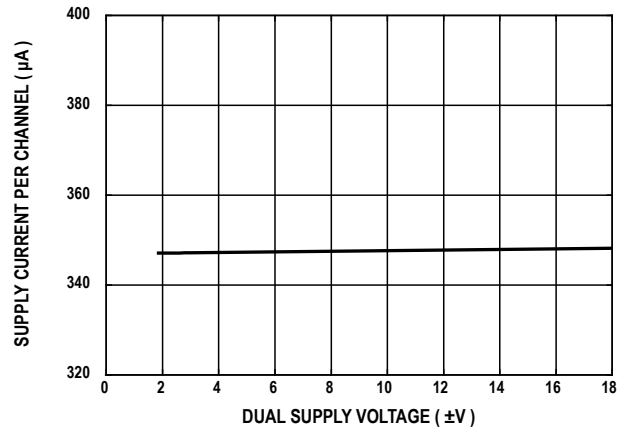

Figure 25. Supply Current per Channel vs. Dual Supply Voltage ( $V_{IN} = 0 V$ )

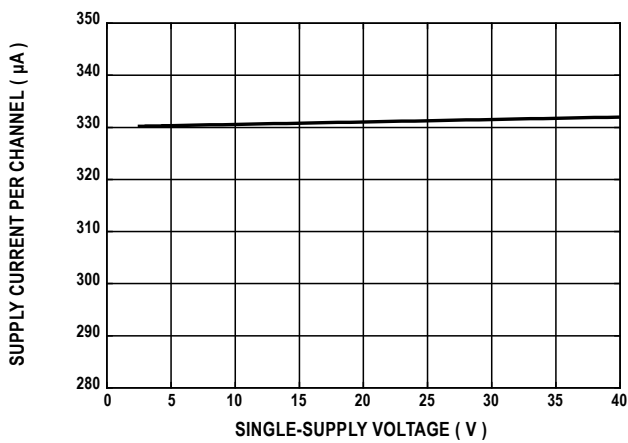

Figure 26. Supply Current per Channel vs. Single Supply Voltage ( $V_{IN} = 0 V$ ,  $V_{REF} = 0 V$ )

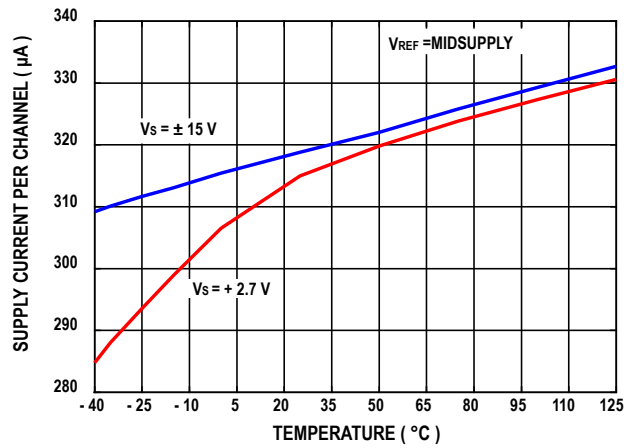

Figure 27. Supply Current per Channel vs. Temperature

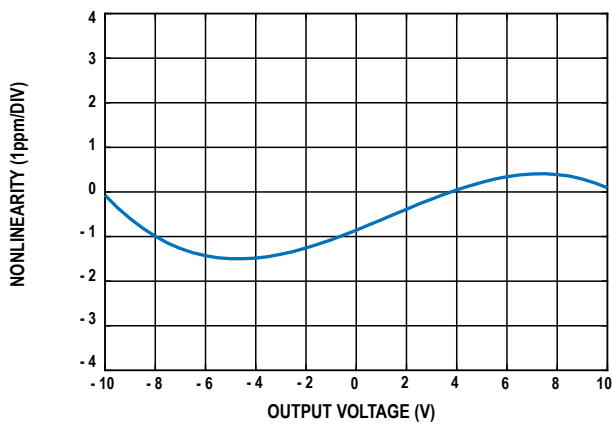

Figure 28. Gain Nonlinearity ( $V_S = \pm 15 V$ ,  $R_L \geq 2 k\Omega$ )

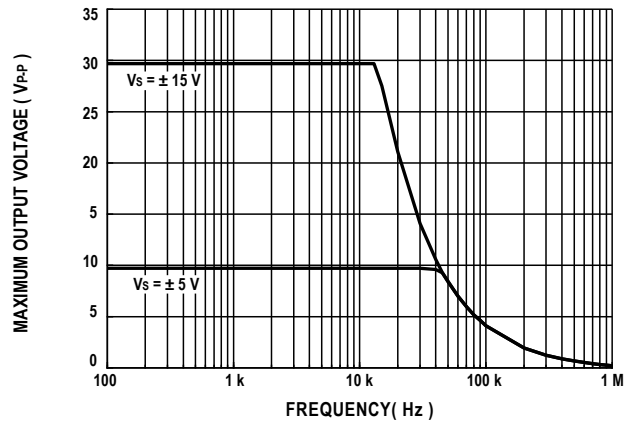
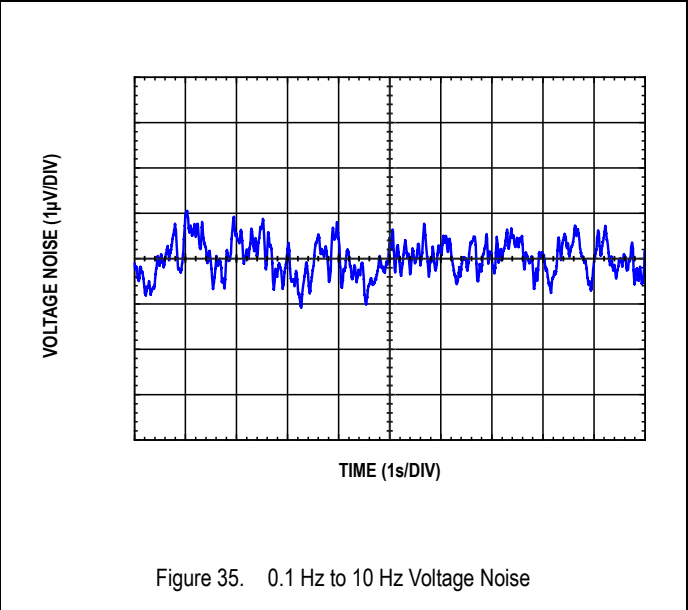
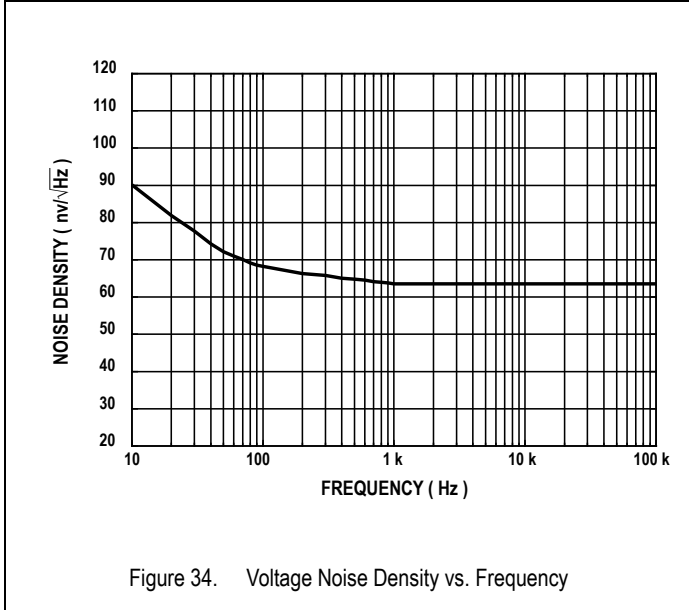
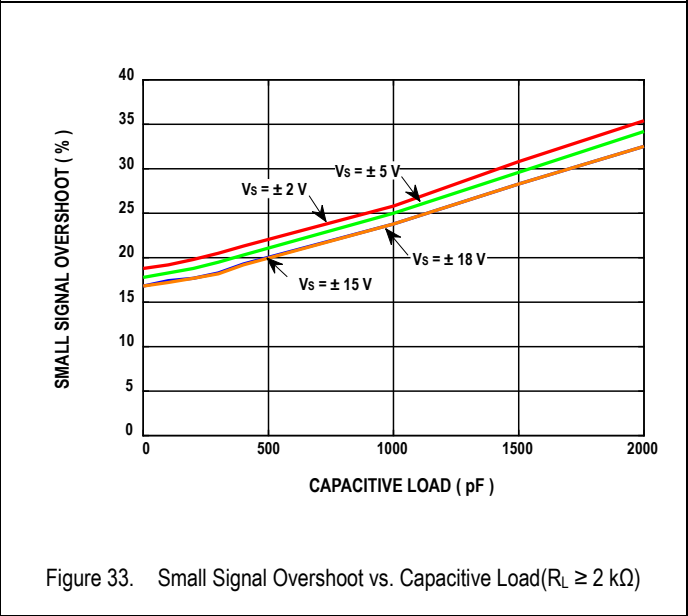
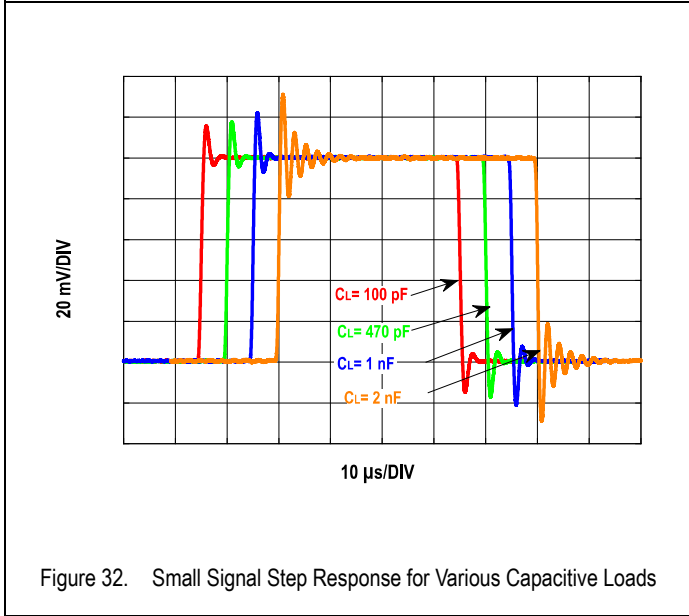
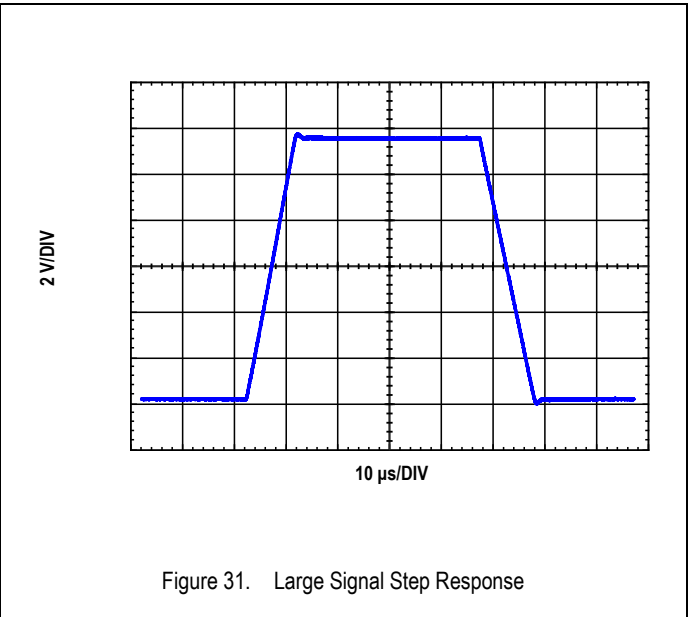
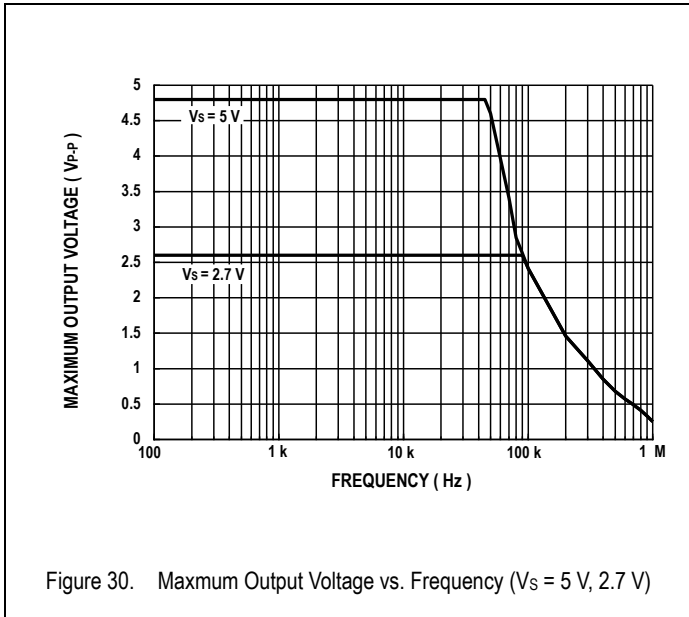

Figure 29. Maximum Output Voltage vs. Frequency ( $V_S = \pm 15 V$ ,  $\pm 5 V$ )



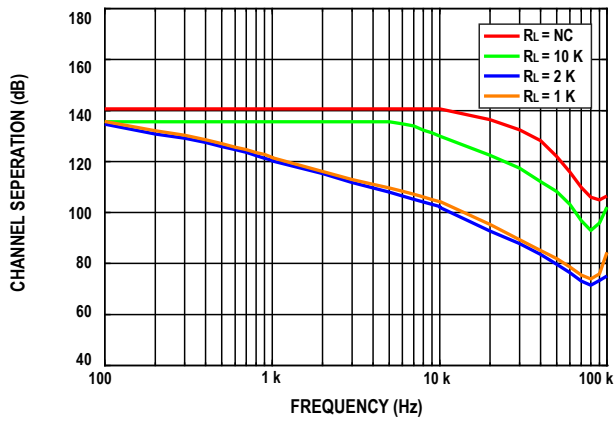

Figure 36. Channel Separation vs. Frequency

## Applications and Implementation

### Configurations

The AD8276/8277 can be configured in several ways (see Figure 40 to Figure 44). Note that Figure 41 shows the AD8276/8277 as difference amplifiers with a midsupply reference voltage at the noninverting input, allowing the AD8276/AD8277 to be used as a level shifter, which is appropriate in single-supply applications that are referenced to midsupply. As with the other inputs, the reference must be driven with a low impedance source to maintain the internal resistor ratio. An example using the low power, low noise AD822 as a reference is shown in Figure 39.

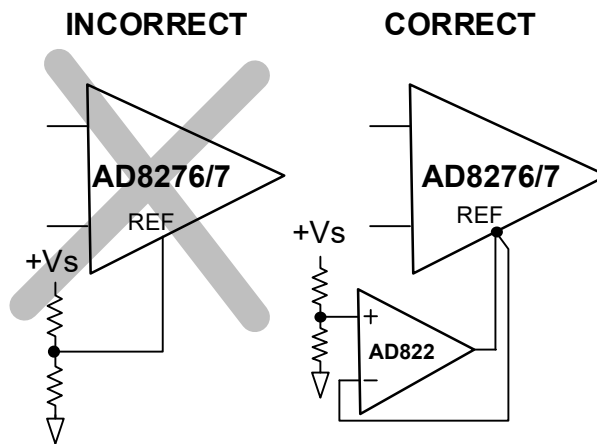

Figure 39. Driving the REF Pin

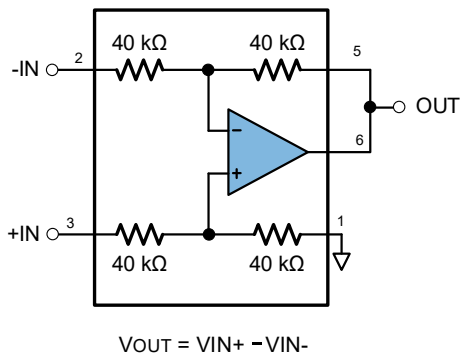

Figure 40. Difference Amplifier, Gain = 1

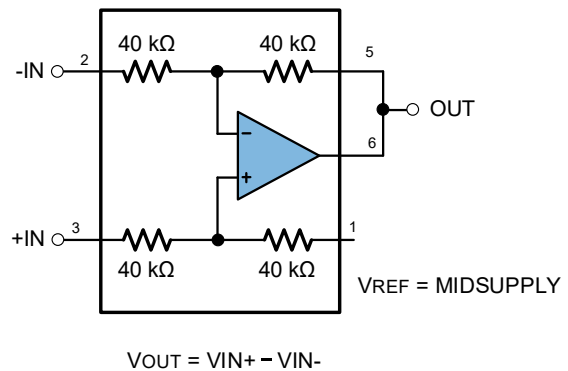

Figure 41. Difference Amplifier, Gain = 1, Referenced to Midsupply

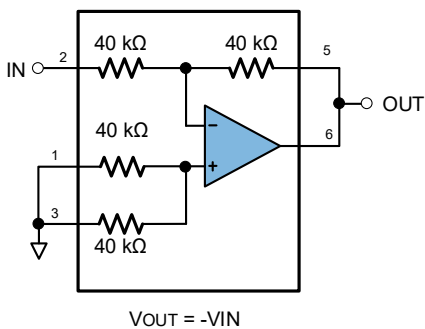

Figure 42. Inverting Amplifier, Gain = -1

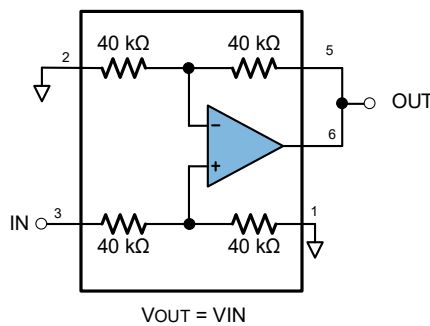

Figure 43. Noninverting Amplifier, Gain = 1

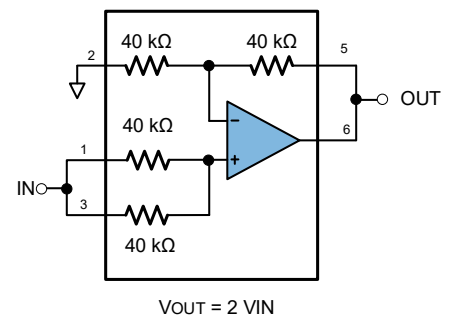

Figure 44. Noninverting Amplifier, Gain = 2



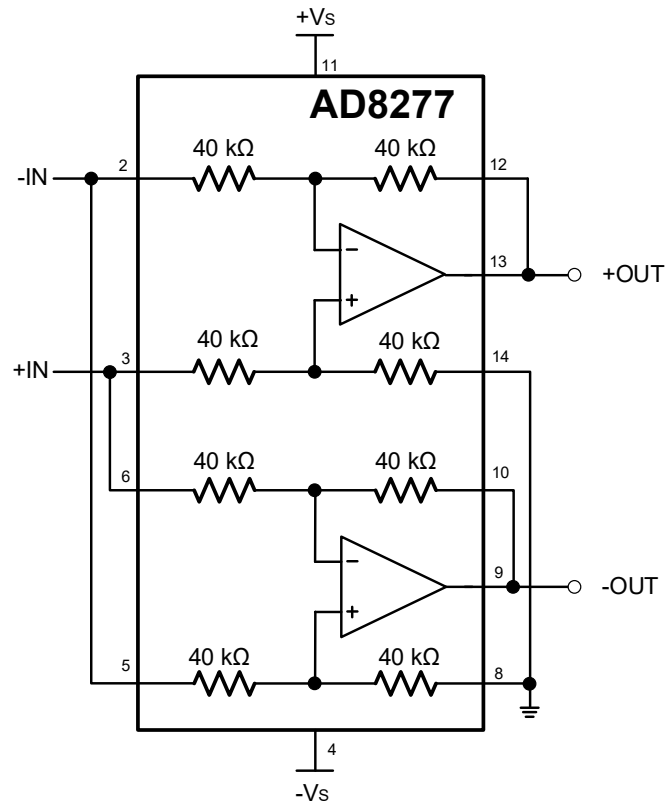

Figure 46. AD8277 Differential Output Configuration

The two difference amplifiers of the AD8277 can be configured to provide a differential output, as shown in Figure 46. This differential output configuration is suitable for various applications. The differential output voltage has a gain of 2 as shown in the following equation:

$$V_{DIFF\_OUT} = V_{+OUT} - V_{-OUT} = 2 \cdot (V_{+IN} - V_{-IN})$$

### Current Source

The AD8276 difference amplifier can be implemented as part of a voltage to current converter or a precision constant current source, as shown in Figure 47. Using an integrated precision solution such as the AD8276/AD8277 provides several advantages over a discrete solution, including space-saving, improved gain accuracy, and temperature drift. The internal resistors are tightly matched to minimize error and temperature drift. If the external resistors,  $R_1$  and  $R_2$ , are not well matched, they become a significant source of error in the system. Therefore, precision resistors or MAX5491 are recommended to maintain performance. The ADR441 provides a precision voltage reference that also reduces error in the signal chain.

The AD8276 has rail-to-rail output capability that allows higher current outputs.

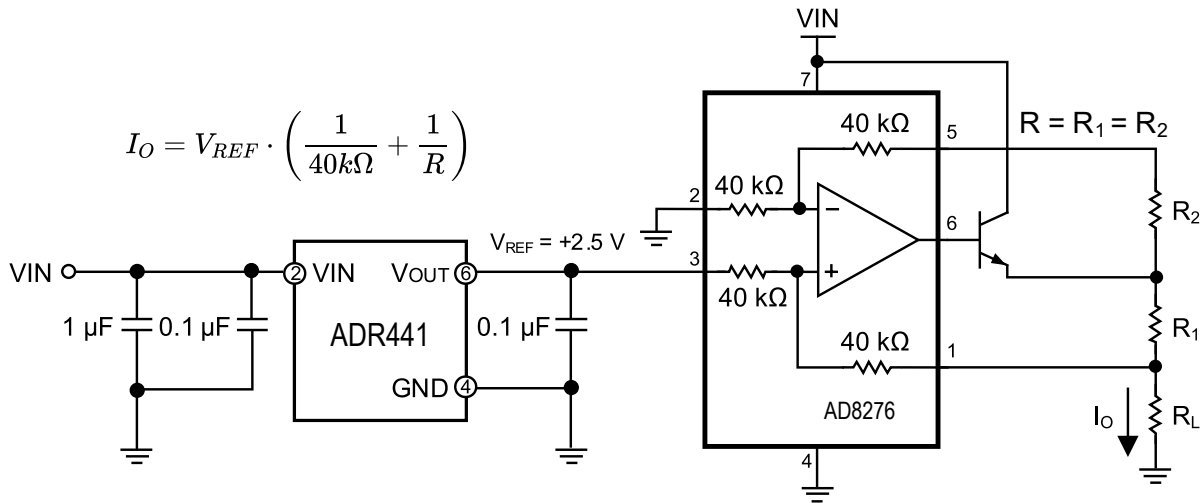

Figure 47. Building Constant Current Source by ADR441 and AD8276

### Voltage and Current Monitoring

Voltage and current monitoring are critical in the following applications: power line protection, motor control applications, and battery monitoring. The AD8276/AD8277 can be used to monitor voltages and currents in a system especially the sensor interface is differential and following signal conditioning is in single-ended, as shown in Figure 48

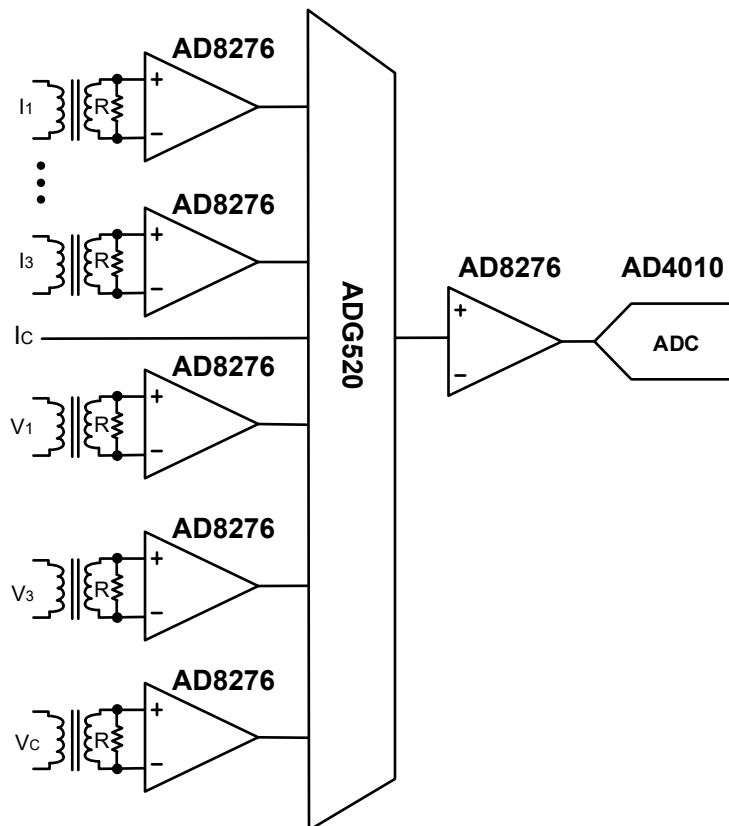

Figure 48. Voltage and Current Monitoring in 3-Phase Power Line Protection Using the AD8276

Figure 48 shows an example of how the AD8276 can be used to monitor voltage and current on a 3-phase power supply.  $I_1$  through  $I_3$  are the currents to be monitored, and  $V_1$  through  $V_3$  are the voltages to be monitored on each phase.  $I_C$  and  $V_C$  are the common or zero

lines. Couplers or transformers interface the power lines to the front-end circuitry and provide attenuation, isolation, and protection. On the current monitoring side, current transformers (CTs) step down the power line current and isolate the front-end circuitry from the high voltage and high current lines. Across the inputs of each difference amplifier is a shunt resistor that converts the coupled current into a voltage. The value of the resistor is determined by the characteristics of the coupler or transformer and desired input voltage ranges to the AD8276. On the voltage monitoring side, potential transformers (PTs) are used to provide coupling and galvanic isolation. The AD8276 helps to build a robust system because it allows input voltages that are almost double its supply voltage, while providing additional input protection in the form of the integrated ESD diodes.

Not only does the AD8276 /AD8277 monitor the voltage and currents on the power lines, the AD8276 is able to reject very high common-mode voltages that may appear at the inputs. The AD8276 also performs the differential to single-ended conversion on the input voltages. The 80 kΩ differential input impedance that the AD8276 presents is high enough that it does not load the input signals.

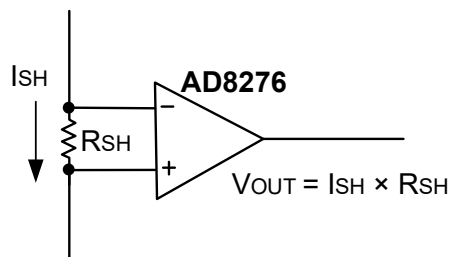
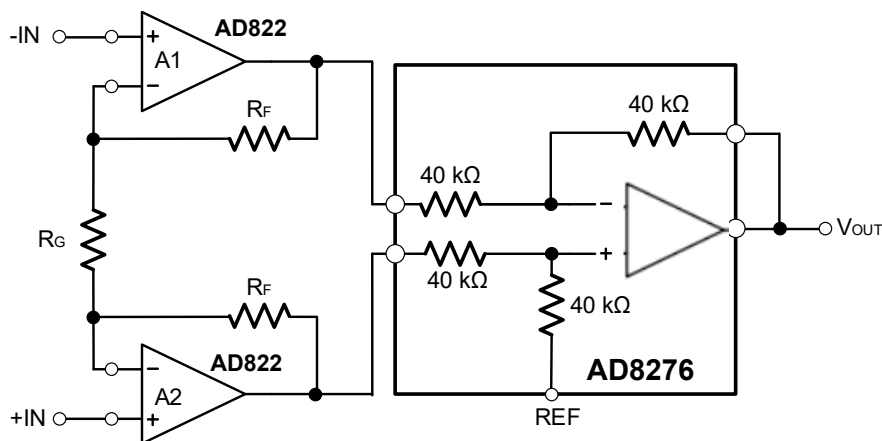

Figure 49. AD8276 Monitoring Current Through a Shunt Resistor

Figure 49 shows how the AD8276 can be used to monitor the current through a small shunt resistor ( $R_{SH}$ ), which is useful in applications such as motor control and battery monitoring. AD8276's high precision and exceptional CMRR delivers the system accuracy.

### Building Instrumentation Amplifier

The AD8276 can be used as building blocks for a low power, low cost instrumentation amplifier. An instrumentation amplifier provides high impedance inputs and delivers high CMRR.



$$V_{OUT} = \left(1 + 2 \frac{R_F}{R_G}\right) (V_{+IN} - V_{-IN})$$

Figure 50. Building Low Power Precision Instrumentation Amplifier by AD822 and AD8276

## Layout Guidelines

For best operational performance of the device, use good PCB layout practices, including:

- Noise can propagate into analog circuitry through the power pins of the circuit as a whole and op amp itself. Bypass capacitors are used to reduce the coupled noise by providing low-impedance power sources local to the analog circuitry.
  - Connect low-ESR, 0.1- $\mu$ F ceramic bypass capacitors between each supply pin and ground, placed as close to the device as possible. A single bypass capacitor from V+ to ground is applicable for single-supply applications.
- Separate grounding for analog and digital portions of circuitry is one of the simplest and most-effective methods of noise suppression. One or more layers on multilayer PCBs are usually devoted to ground planes. A ground plane helps distribute heat and reduces EMI noise pickup. Make sure to physically separate digital and analog grounds paying attention to the flow of the ground current.
- In order to reduce parasitic coupling, run the input traces as far away from the supply or output traces as possible. If these traces cannot be kept separate, crossing the sensitive trace perpendicular is much better as opposed to in parallel with the noisy trace.
- Place the external components as close to the device as possible in order to minimize parasitic capacitance.
- Keep the length of input traces as short as possible. Always remember that the input traces are the most sensitive part of the circuit.
- Consider a driven, low-impedance guard ring around the critical traces. A guard ring can significantly reduce leakage currents from nearby traces that are at different potentials.
- Cleaning the PCB following board assembly is recommended for best performance.
- Any precision integrated circuit may experience performance shifts due to moisture ingress into the plastic package. Following any aqueous PCB cleaning process, baking the PCB assembly is recommended to remove moisture introduced into the device packaging during the cleaning process. A low temperature, post cleaning bake at 85 °C for 30 minutes is sufficient for most circumstances.

Layout Example

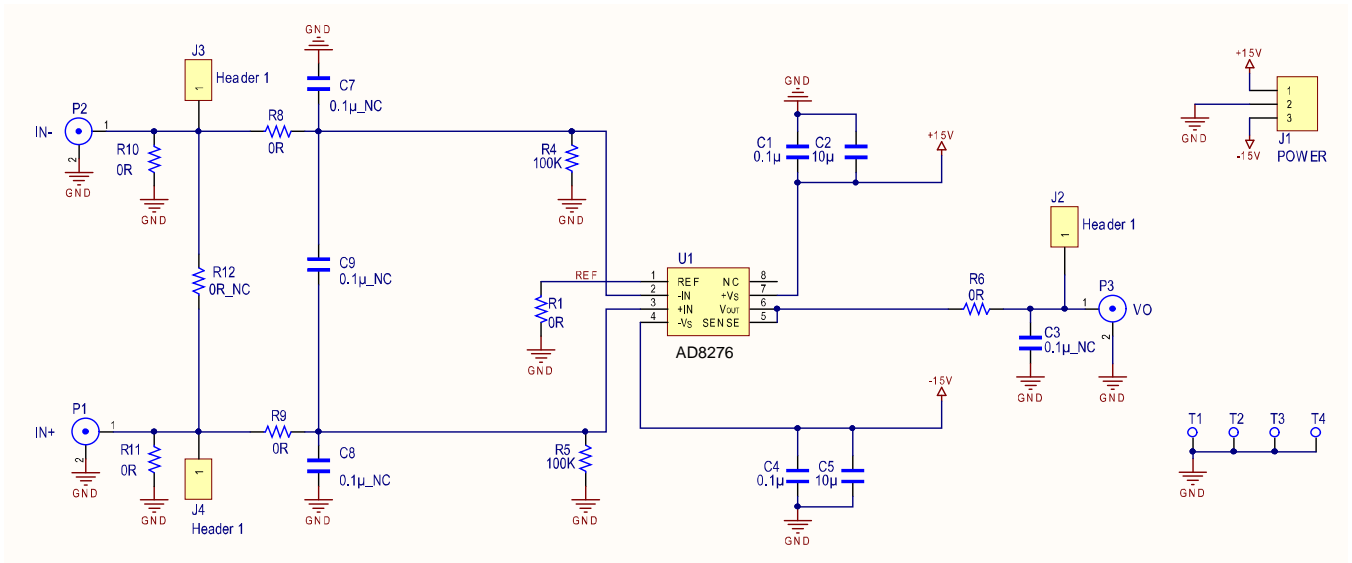

Figure 51. AD8276 Evaluation Board Schematic

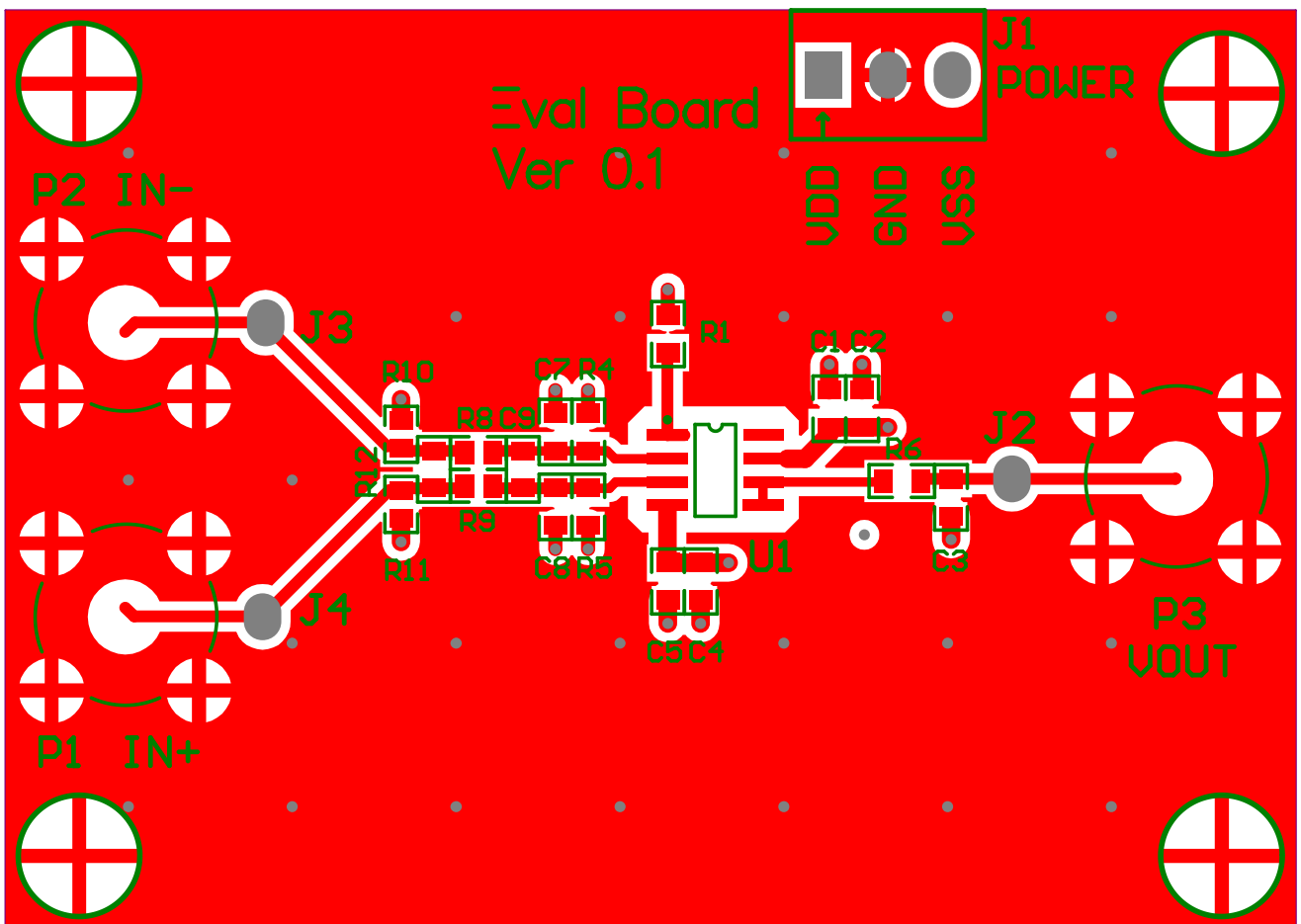

Figure 52. Layout of AD8276 Evaluation Board (Top Layer)

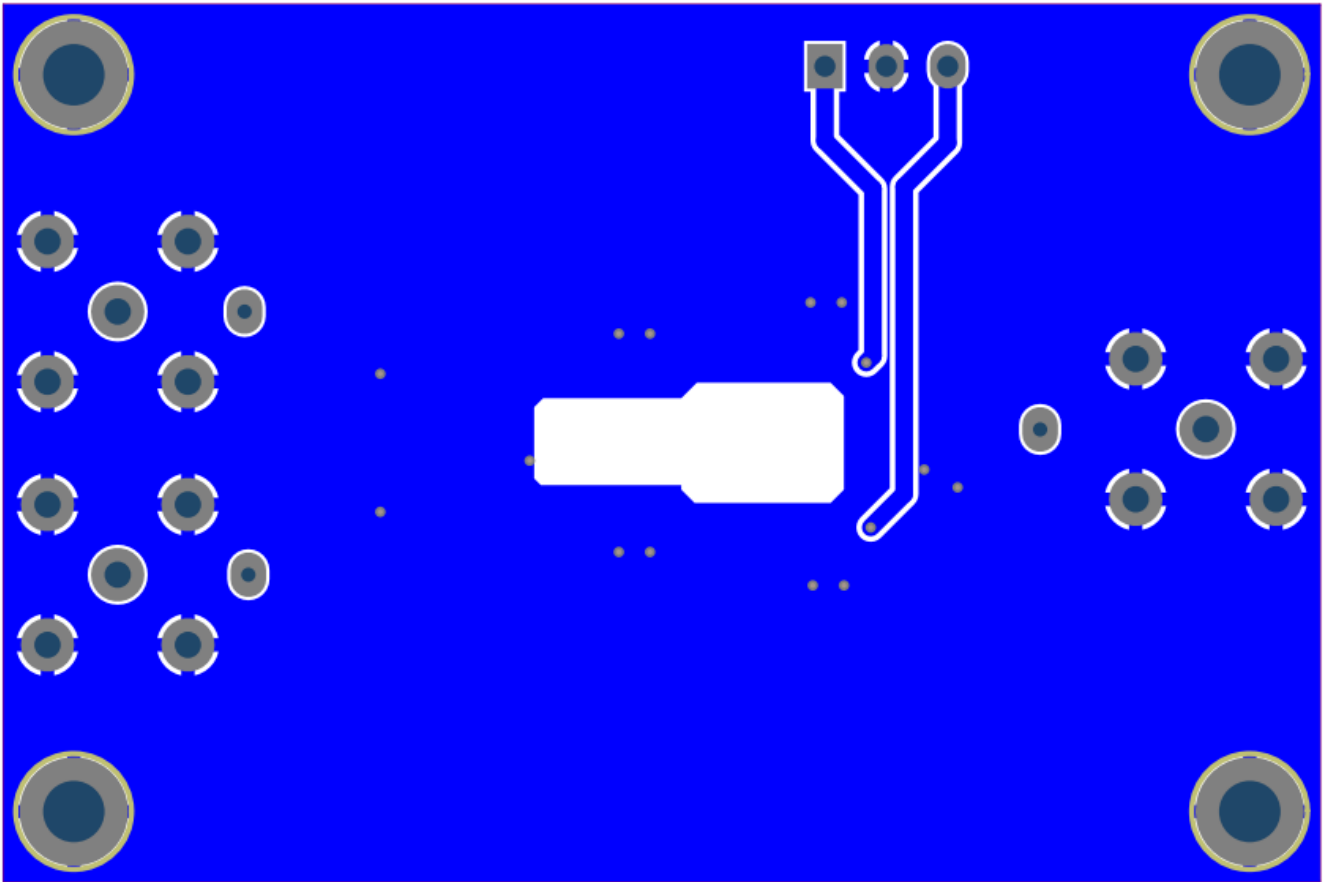

Figure 53. Layout of AD8276 Evaluation Board (Bottom Layer)

Outline Dimensions

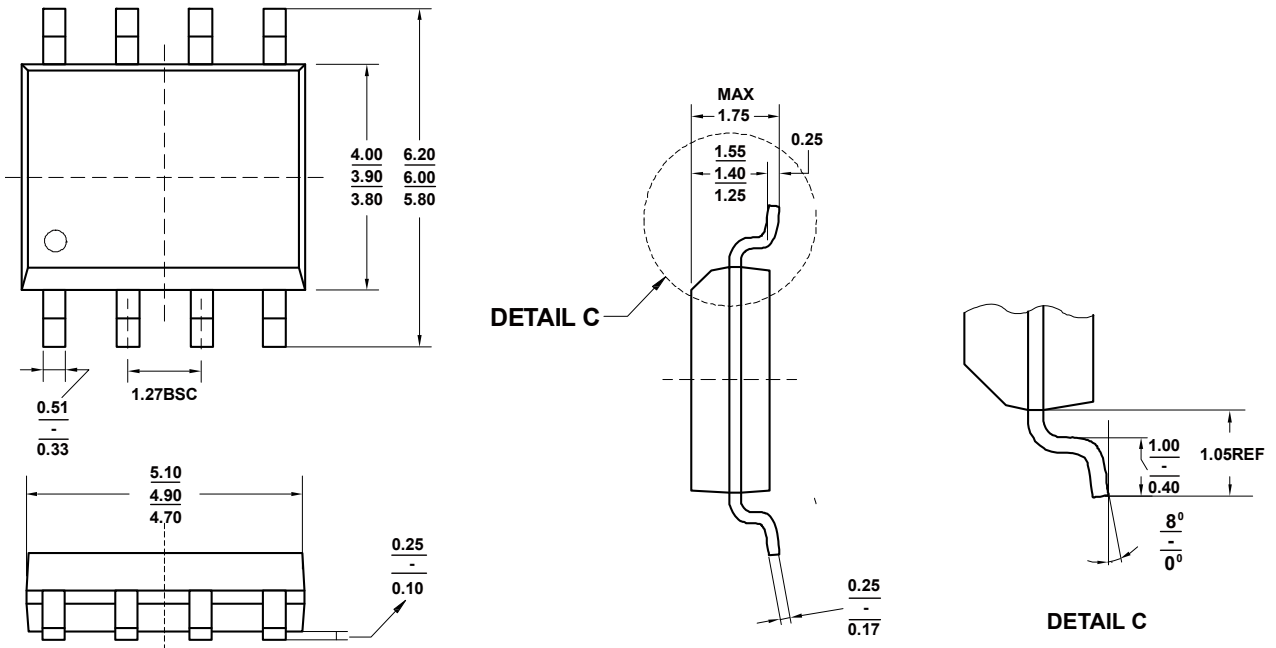

Figure 54. 8-Lead SOIC Package Dimensions shown in millimeters

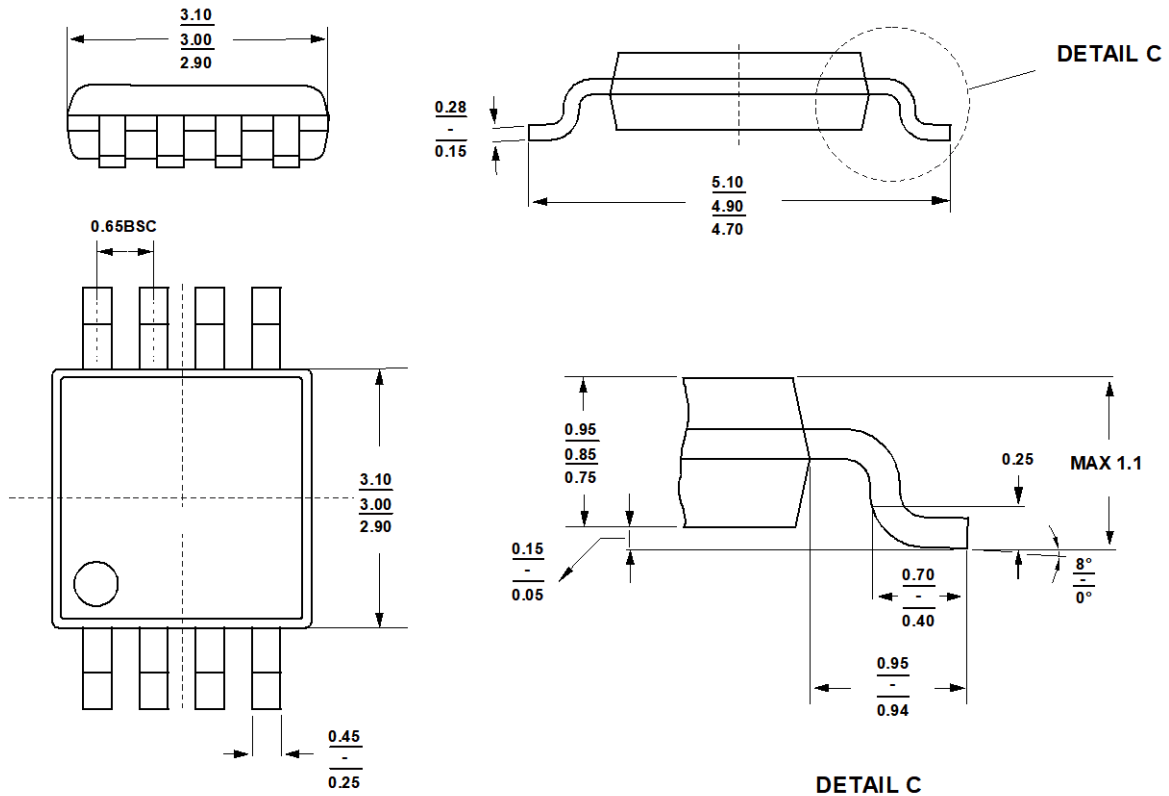

Figure 55. 8-Lead MSOP Package Dimensions shown in millimeters

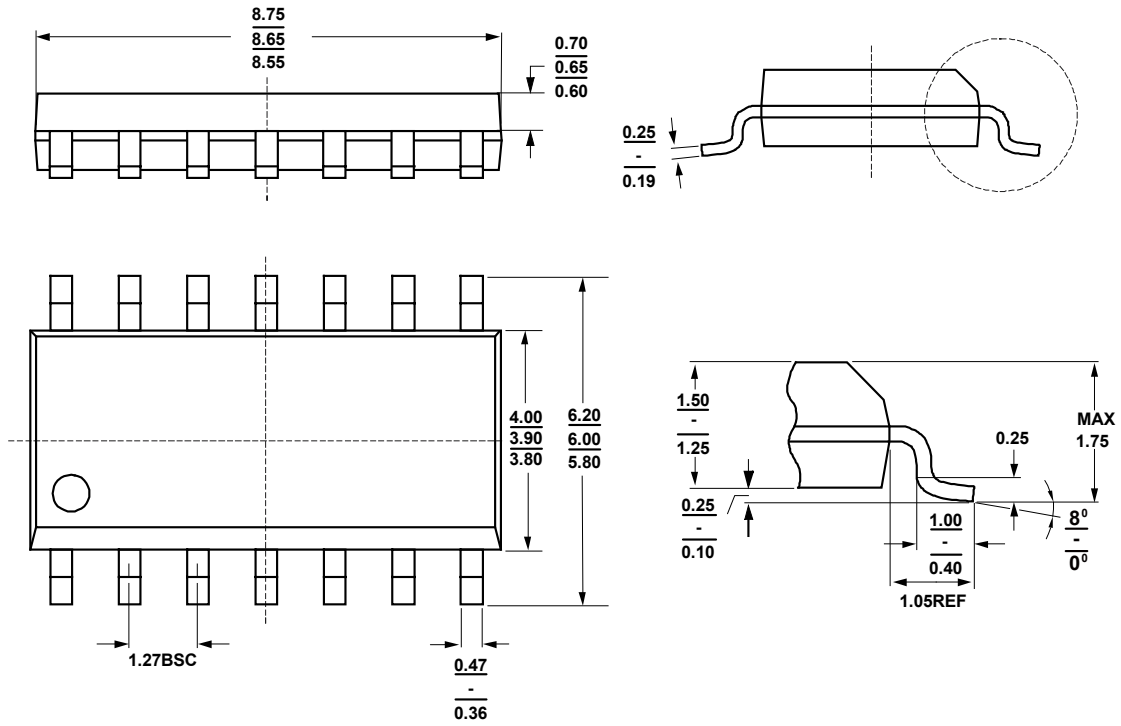

Figure 56. 14-Lead SOIC Package Dimensions shown in millimeters

## Ordering Guide

Model	Orderable Device	Status <sup>1</sup>	Vos max. ( $\mu$ V)	Package	External Package
AD8276	AD8276AR	ACTIVE	100	SOIC-8	Tube
	AD8276AS	ACTIVE			13" reel
	AD8276ARZ	ACTIVE	300	SOIC-8	Tube
	AD8276ARZ-R7	ACTIVE			13" reel
	AD8276BR	ACTIVE	100	MSOP-8	Tube
	AD8276BS	ACTIVE			13" reel
	AD8276BRZ	ACTIVE	300	MSOP-8	Tube
	AD8276BRZ-R7	ACTIVE			13" reel
AD8277	AD8277BRZ	ACTIVE	100	SOIC-14	Tube
	AD8277BRZ-RL	ACTIVE			13" reel
	AD8277ARZ	ACTIVE	300	SOIC-14	Tube
	AD8277ARZ-RL	ACTIVE			13" reel