

3A Low Dropout Regulator

Features

- High Current Capability: 3.0A
- Wide Input Voltage Range: 4~18V
- Low Dropout Voltage
- Low Ground Current
- Accurate 2% Tolerance
- Fast Transient Response
- Adjustable Output Voltage
- Extended Temperature Ranges
From -40°C to +125°C
- Available in Green TO-263 and TO-220

Applications

- Automotive Electronics
- Battery-Powered Equipment
- High-Efficiency Linear Power Supplies
- High-Efficiency Green Computer Systems
- High-Efficiency Post-Regulator for Switching Supply

General Description

The COS29302D is a high current, high accuracy, low dropout voltage (LDO) regulator which features 350 mV to 425 mV (full load) typical dropout voltages and very low ground current. Designed for high current loads, the device also finds applications in lower current, extremely low dropout critical systems, where their tiny dropout voltage and ground current values are important attributes.

The COS29302D are fully protected against overcurrent faults, reversed input polarity, reversed lead insertion, over temperature operation, and positive and negative transient voltage spikes. Five pin versions feature logic level ON/OFF control (COS29302D) and an error flag that signals whenever the output falls out of regulation (COS29303D). Flagged states include low input voltage (drop out), output current limit, over temperature shutdown, and extremely high voltage spikes on the input.

Rev1.0

Copyright©2018 Cosine Nanoelectronics Inc. All rights reserved
The information provided here is believed to be accurate and reliable. Cosine Nanoelectronics assumes no reliability for inaccuracies and omissions. Specifications described and contained here are subjected to change without notice on the purpose of improving the design and performance. All of this information described herein should not be implied or granted for any third party.

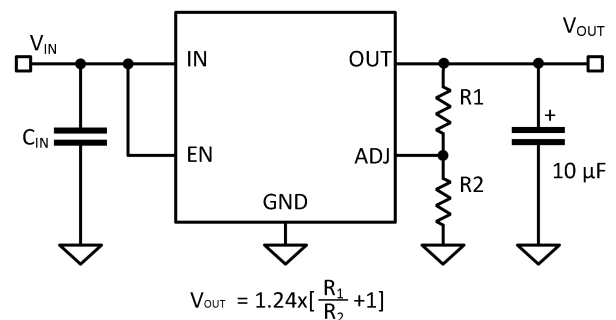

Typical Application Circuits

1 Pin Configuration and Functions

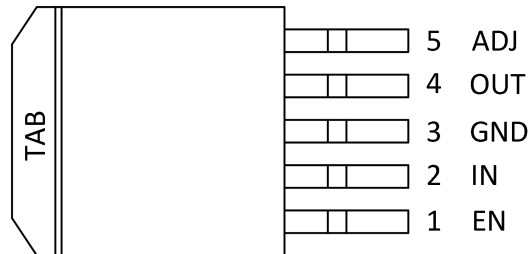

Pin Functions

Pin No	Pin Name	I/O	Description
2	IN	I	INPUT: Supplies the current to the output power device.
4	OUT	O	OUTPUT: The regulator output voltage.
3	GND	-	GROUND
1	EN	I	ENABLE: Available for COS29xx2. CMOS compatible control input. Logic-high=enable, logic-low=shutdown
5	ADJ	I	ADJUST: Adjustable regulator feedback input that connects to the resistor voltage divider that is placed from OUT to GND in order to set the output voltage.
-	TAB	-	Internally connected directly to the device pin3 (GND). The thermal tab must be connected to a copper area on the PCB at the same potential as device pin3 (GND) to assure thermal performance, or leave the thermal tab floating. Do NOT connect the thermal tab to any potential other than the same potential at device pin3.

2 Package and Ordering Information

Model	Order Number	Package	Package Option	Marking Information
COS29302D	COS29302D	TO-263-5	Tape and Reel, 800	COS29302WU

3 Product Specification

3.1 Absolute Maximum Ratings ⁽¹⁾

Parameter	Rating	Units
Maximum Input Voltage: V_{IN}	19	V
Enable Input Voltage	- 0.3V to V_{IN}	V
Storage Temperature Range	-55 to 150	°C
Operating Junction Temperature	-40 to 125	°C
ESD Susceptibility, HBM	2000	V

(1) Stresses exceeding the absolute maximum ratings may damage the device. The device may not function or be operable above the recommended operating conditions and stressing the parts to these levels is not recommended. In addition, extended exposure to stresses above the recommended operating conditions may affect device reliability. The absolute maximum ratings are stress ratings only.

3.2 Thermal Data

Parameter	Rating	Unit
Package Thermal Resistance, $R_{\theta JC}$ (Junction-to-case)	2 (TO-220) 3 (TO-263)	°C/W

3.3 Recommended Operating Conditions

Parameter	Rating	Unit
Input Supply Voltage	+4.5V ~ +18V	V
Operating Ambient Temperature	-40 to +85	°C

3.4 Electrical Characteristics

($V_{IN}=V_{OUT}+1V$, $I_{OUT}=100mA$, $T_A=+25^{\circ}C$, unless otherwise noted)

Parameter	Symbol	Conditions	Min.	Typ.	Max.	Unit
Output Voltage						
Output Voltage	V_{OUT}	$I_{OUT}=10mA$	-1	-	+1	%
		$10mA \leq I_{OUT} \leq I_{FL}$, ($V_{OUT}+1V \leq V_{IN} \leq 18V$)	-2	-	+2	%
Line Regulation		$I_{OUT}=10mA$, ($V_{OUT}+1V \leq V_{IN} \leq 18V$)		0.3	1	%
Load Regulation		$10mA \leq I_{OUT} \leq 1.5A$		0.2	3	%
Output Voltage Temperature Coefficient	$\Delta V_o / \Delta T$			20	100	ppm/ $^{\circ}C$
Dropout Voltage $\Delta V_{OUT} = -1\%$		$I_{OUT}=100mA$	-	80	175	mV
		$I_{OUT}=1.5A$	-	250	-	
		$I_{OUT}=3A$	-	370	600	
Current Limit	I_{LIM}	$V_{OUT}=0V$	-	4.0	4.8	A
Output Noise Voltage	e_n	$C_L=10\mu F$, $I_L=100mA$, 10Hz to 100kHz	-	390	-	μV_{rms}
		$C_L=33\mu F$, $I_L=100mA$, 10Hz to 100kHz	-	211	-	μV_{rms}
Ground Current						
Ground Current ($V_{IN} = V_{OUT} + 1V$)	I_{GND}	$I_{OUT}=1.5A$	-	5	-	mA
		$I_{OUT}=3A$	-	28	-	
Ground Pin Current at Dropout (V_{IN} is 0.5V less than specified V_{OUT})	I_{GRNDDO}	$I_{OUT}=10mA$	-	2	-	mA
Ground Current in Shutdown			-	5	75	nA
Reference						
Reference Voltage			1.22	1.240	1.252	V
Reference Voltage Temperature Coefficient			-	20	-	ppm/ $^{\circ}C$
Adjust Pin Bias Current			-	-	100	pA
ENABLE Input						
Input Logic Voltage Low (OFF)			-	-	0.8	V
Input Logic Voltage High (ON)			2.4	-	-	V
Enable Pin Input Current		$V_{EN}=0.8V$	-	-	24	pA
		$V_{EN}=26V$	-	-	3	nA
Regulator Output Current in Shutdown		$-40^{\circ}C \leq T_J \leq +125^{\circ}C$	-	-	18	μA

4 Application Notes

The COS29302D is a high-performance low-dropout voltage regulator suitable for all moderate-current voltage regulator applications. Their 350 mV to 425 mV typical dropout voltage at full load make them especially valuable in battery powered systems and as high efficiency noise filters in post-regulator applications.

The COS29302D is fully protected from damage due to fault conditions. Current limiting is provided. This limiting is linear; output current under overload conditions is constant. Thermal shutdown disables the device when the die temperature exceeds the +125°C maximum safe operating temperature. Line transient protection allows device and load survival even when the input voltage spikes between 0 and +18V. COS29302D offers a logic-level ON/OFF control. When disabled, the devices draw nearly zero current.

4.1 Typical Application Circuit

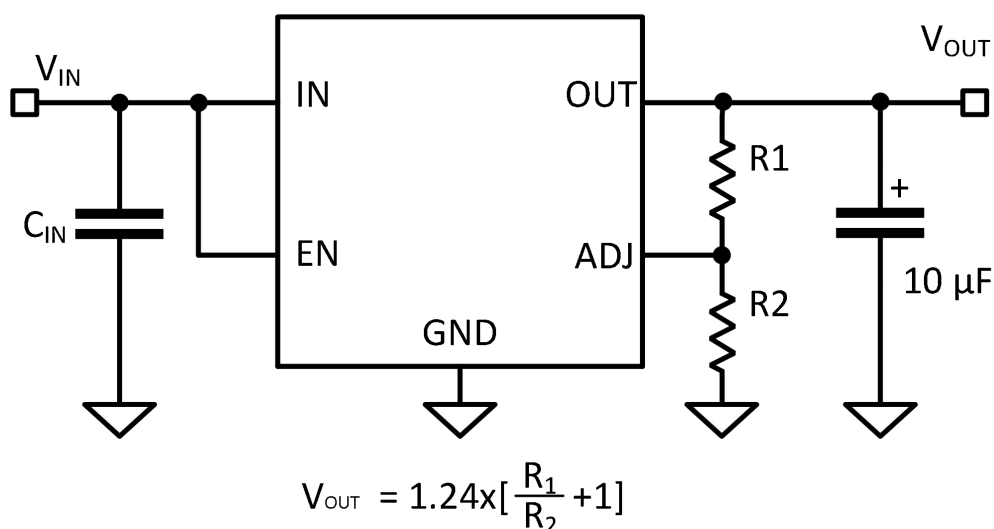

Figure 1 Typical Application Circuit

4.2 Adjustable Regulator Design

COS29302D allows programming the output voltage anywhere between 1.25V and the 18V. Two external resistors are used in the typical application circuit as shown in Figure 1 . The resistor values are calculated by following equation.

$$R_1 = R_2 \times (V_{OUT}/1.240 - 1)$$

In the equation above, V_{OUT} is the desired output voltage. The resistor value between V_{OUT} and the adjust pin should not exceed 10k Ω . Larger values can cause instability. Applications with widely varying load currents may scale the resistors to draw the minimum load current required for proper operation.

4.3 Capacitor Requirements

For stability and minimum output noise, a capacitor on the regulator output is necessary. The value of this capacitor is dependent upon the output current; lower currents allow smaller capacitors. The COS29302D regulator are stable with the minimum capacitor values of 10 μ F at full load. This capacitor need not be an expensive low ESR type: aluminum electrolytics are adequate. In fact, extremely low ESR capacitors may contribute to instability. Tantalum capacitors are recommended for systems where fast load transient response is important where the regulator is powered from a source with high AC impedance, a 0.1 μ F capacitor connected between Input and GND is recommended. This capacitor should have good characteristics to above 250 kHz.

4.4 Minimum Load Current

The COS29302D regulators are specified between finite loads. If the output current is too small, leakage currents dominate and the output voltage rises. The 7mA minimum load current swamps any expected leakage current across the operating temperature range

4.5 Enable Input

COS29302D versions feature an enable (EN) input that allows ON/OFF control of the device. Special design allows “zero” current drain when the device is disabled; only micro-amperes of leakage current flows. The EN input has TTL/CMOS compatible thresholds for simple interfacing with logic, or may be tied to V_{IN} if it is not required for ON/OFF control.

5 Package Information

5.1 TO-263-5 (Package Outline Dimensions)

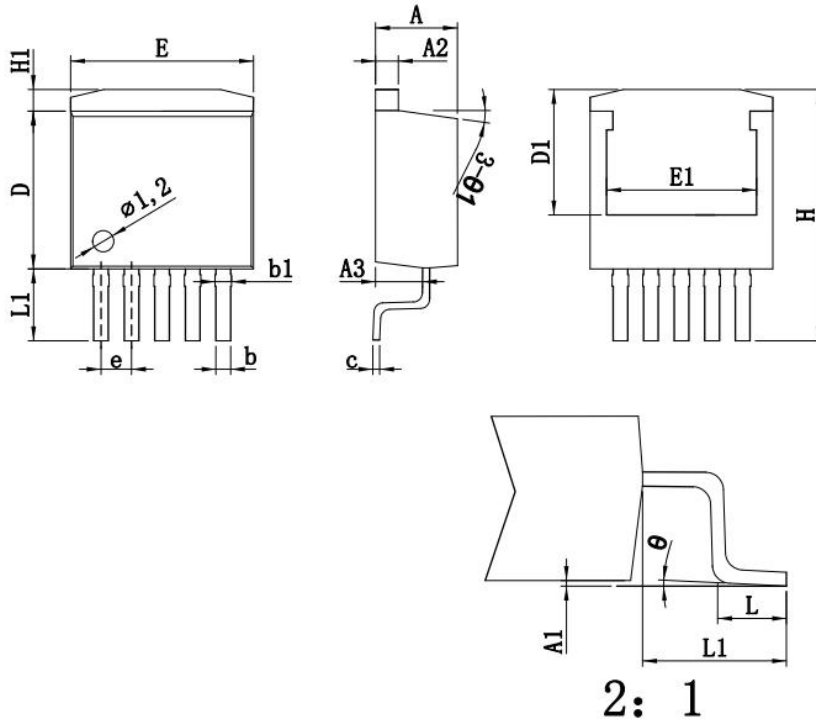

SYMBOL	mm		
	MIN	NOM	MAX
*A	4.45	4.55	4.62
*A1	0.02	0.12	0.20
*A2	1.24	1.27	1.32
A3	2.50	2.62	2.75
*b	0.70	0.81	0.90
*b1	0.81	0.90	0.98
*c	0.35	0.38	0.43
*D	8.50	8.60	8.70
D1	6.97REF		
*E	9.95	10.12	10.28
E1	8.33REF		
*e	1.65	1.70	1.75
e1	1.65	1.70	1.75
*H	13.90	14.03	14.15
H1	1.10	1.23	1.36
*L	1.70	1.90	2.10
L1	3.93	4.03	4.13
*θ	1°	2.5°	5°
θ1	5°	-	11°

*critical control dimensions