

Features

- Wide Common-Mode Range: 0 V to 36 V
- Selectable Response Times:
 - 10 μ s, 50 μ s, 100 μ s
- Programmable Threshold:
 - Adjust Using a Single Resistor
 - Programmable from 0 mV to 250 mV
- Accuracy:
 - Offset Voltage: 180 μ V (Typical)
 - Offset Voltage Drift: 1.61 μ V/ $^{\circ}$ C (Maximum)
- Selectable Hysteresis:
 - 2 mV, 4 mV, 8 mV
- Active Quiescent Current: 310 μ A (Maximum)
- Selectable Disable Mode
 - Disabled Quiescent Current: 2 μ A
 - Disabled Input Bias Current: 80 nA
- Open-Drain Output with Latch Mode

Applications

- Overcurrent Protection
- Computers
- Servers
- Telecom Equipment
- Power Supplies

Description

The device is a current-sensing comparator that detects overcurrent by measuring the voltage developed across a shunt resistor and comparing the voltage to the threshold voltage. The device measures this differential voltage signal on common-mode voltages which can vary from 0 V up to 36 V, independent of the supply voltage. The device features an adjustable threshold range that can be set by a single external resistor or an external voltage source at the limit terminal.

An open-drain alert output on the device can be configured to operate in either direct mode where the output status follows the input state, or in a latched mode where the alert output is cleared when the latch is cleared. The response time setting of the device is selectable, which enables overcurrent alerts to be issued in 10 μ s, 50 μ s, and 100 μ s.

The device operates from a single 2.7-V to 5.5-V supply, drawing a supply current of 270 μ A. The device is specified over the extended operating temperature range from -40° C to $+125^{\circ}$ C and is available in the DFN2 \times 2-10 and MSOP10 packages.

Typical Application Circuit

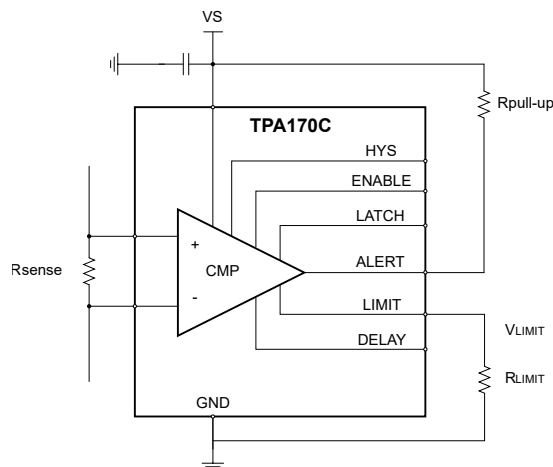

Table of Contents

Features	1
Applications	1
Description	1
Typical Application Circuit	1
Revision History	3
Pin Configuration and Functions	4
Specifications	5
Absolute Maximum Ratings ⁽¹⁾	5
ESD, Electrostatic Discharge Protection.....	5
Recommended Operating Conditions.....	5
Thermal Information.....	5
Electrical Characteristics.....	6
Typical Performance Characteristics.....	8
Detailed Description	11
Overview.....	11
Feature Description.....	11
Tape and Reel Information	14
Package Outline Dimensions	15
DFN2×2-10.....	15
MSOP10.....	16
Order Information	17
IMPORTANT NOTICE AND DISCLAIMER	18

Revision History

Date	Revision	Notes
2024-10-18	Rev.A.0	Initial version.
2024-12-18	Rev.A.1	The following updates are all about the new datasheet formats or typos, and the actual product remains unchanged. <ul style="list-style-type: none"><li data-bbox="550 573 1018 607">• Updated the Tape and Reel Information.
2025-12-01	Rev.A.2	Added the thermal pad description in the Pin Configuration and Functions. The actual product remains unchanged.

Pin Configuration and Functions

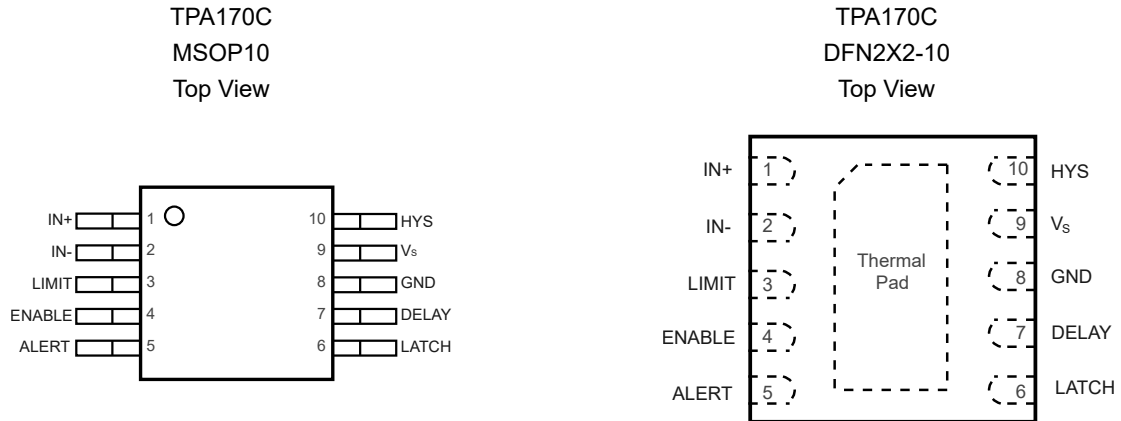

Table 1. Pin Functions

Pin No.	Name	I/O	Description
1	IN+	Analog I	Connected to the supply side of the shunt resistor.
2	IN-	Analog I	Connected to the load side of the shunt resistor.
3	LIMIT	Analog I	Alert threshold limit input.
4	ENABLE	Digital I	Enable or disable selection input.
5	ALERT	Digital O	Over limit alert, active-low, and open-drain output.
6	LATCH	Digital I	Transparent or latch mode selection input.
7	DELAY	Digital I	Response time selection input.
8	GND	Power Supply	Ground.
9	V _s	Power Supply	Power supply, 2.7 V to 5.5 V.
10	HYA	Digital I	Hysteresis setting input.
	Thermal Pad		This pad can be connected to GND or left floating.

36-V, Overcurrent-Protection, Current Sense Comparator
Specifications
Absolute Maximum Ratings ⁽¹⁾

Parameter		Min	Max	Unit
V _S	Supply Voltage		6.5	V
Analog Input, IN+, IN-	Differential (IN+) – (IN-)	-40	40	V
	Input Common Voltage	GND – 0.3	40	V
	Input Current: IN+, IN-	-10	+10	mA
T _J	Maximum Junction Temperature		150	°C
T _A	Operating Temperature Range	-40	125	°C
T _{STG}	Storage Temperature Range	-65	150	°C
T _L	Lead Temperature (Soldering, 10 sec)		260	°C

(1) Stresses beyond those listed under Absolute Maximum Ratings may cause permanent damage to the device. Exposure to any Absolute Maximum Rating condition for extended periods may affect device reliability and lifetime.

ESD, Electrostatic Discharge Protection

Symbol	Parameter	Condition	Minimum Level	Unit
HBM	Human Body Model ESD	ANSI/ESDA/JEDEC JS-001 ⁽¹⁾	2	kV
CDM	Charged Device Model ESD	ANSI/ESDA/JEDEC JS-002 ⁽²⁾	1.5	kV

(1) JEDEC document JEP155 states that 500-V HBM allows safe manufacturing with a standard ESD control process.

(2) JEDEC document JEP157 states that 250-V CDM allows safe manufacturing with a standard ESD control process.

Recommended Operating Conditions

Parameter		Min	Typ	Max	Unit
V _{CM}	Common-Mode Input Voltage	0	12	36	V
V _S	Supply Voltage	2.7	3.3	5.5	V
	Delay Setting		100		μs
T _A	Operating Temperature Range	-40	25	125	°C

Thermal Information

Package Type	θ _{JA}	θ _{Jc}	Unit
MSOP10	175.5	54.6	°C/W
DFN2×2-10	58.9	89.7	°C/W

36-V, Overcurrent-Protection, Current Sense Comparator
Electrical Characteristics

All test conditions: $V_S = 3.3\text{ V}$, $T_A = 25^\circ\text{C}$, $V_{IN} = V_{IN+} - V_{IN-} = 0\text{ V}$, $V_{CM} = 12\text{ V}$, delay = 100 μs , unless otherwise noted.

Symbol	Parameter	Conditions	Min	Typ	Max	Unit
Input						
V_{OS}	Input Offset Voltage	Delay = 100 μs	-650	180	950	μV
		Delay = 50 μs	-800	50	850	μV
		Delay = 10 μs	-1150	-380	450	μV
$V_{OS\ TC}$	Input Offset Voltage Drift ⁽¹⁾	-40°C to 125°C		1	2	$\mu\text{V}/^\circ\text{C}$
V_{CM}	Common-Mode Input Range	-40°C to 125°C	0		36	V
CMRR	Common-Mode Rejection Ratio	-40°C to 125°C, $V_{CM} = 0\text{ V}$ to 36 V	100	120		dB
V_{IN}	Differential Input Voltage	$V_{IN} = V_{IN+} - V_{IN-}$	0		250	mV
I_B	Input Bias Current ⁽²⁾			10	80	nA
		Disable mode		10	80	nA
I_{OS}	Input Offset Current			± 0.1		μA
I_{LIMIT}	Limit Threshold Output Current		19.85	20	20.15	μA
		-40°C to 125°C	19.75		20.25	μA
PSRR	Power Supply Rejection Ratio	$V_S = 3\text{ V}$ to 5.5 V, -40°C to 125°C			340	$\mu\text{V}/\text{V}$
Output						
t_p	Alert Propagation Delay	Delay = open, Overdrive = 1 mV		10		μs
		Delay = GND, Overdrive = 1 mV		50		μs
		Delay = V_S , Overdrive = 1 mV		100		μs
HYS	Hysteresis	HYS = open		2		mV
		HYS = GND		4		mV
		HYS = V_S		8		mV
V_{IH}	High-Level Input Voltage	Latch, enable	1.4		6	V
		Delay, hysteresis	$V_S - 0.5$		6	V
V_{IL}	Low-Level Input Voltage	Latch, enable			0.4	V
		Delay, hysteresis			0.5	V
V_{OL}	Alert Low-Level Output Voltage	$I_{OL} = 3\text{ mA}$		120	400	mV
	Alert Terminal Leakage Input Current	$V_{OH} = 3.3\text{ V}$		0.1	0.2	μA
	Digital Leakage Input Current	$0 \leq \text{Input Voltage} \leq V_S$		0.8	1	μA
Power Supply						
V_S	Supply Voltage	-40°C to 125°C	2.7		5.5	V
I_Q	Quiescent Current	$V_{SENSE} = 0\text{ mV}$, $T_A = 25^\circ\text{C}$		270	310	μA

36-V, Overcurrent-Protection, Current Sense Comparator

Symbol	Parameter	Conditions	Min	Typ	Max	Unit
		$V_{SENSE} = 0 \text{ mV}$, $T_A = -40^\circ\text{C}$ to 125°C			320	μA
		$V_{SENSE} = 0 \text{ mV}$, disable mode, $HYS = 2 \text{ mV}$		1.4	2	μA
Timing Requirements						
	Start-up Time			40		μs
	Enable Time			35		μs
	Disable Time			15		μs

- (1) Provided by bench tests and design simulation.
(2) The current flowing into the pins is considered positive.

Typical Performance Characteristics

All test conditions: $T_A = 25^\circ\text{C}$, $V_S = 3.3\text{ V}$, $V_{IN+} = 12\text{ V}$, alert pull-up resistor = 10 k Ω , delay = 100 μs , unless otherwise noted.

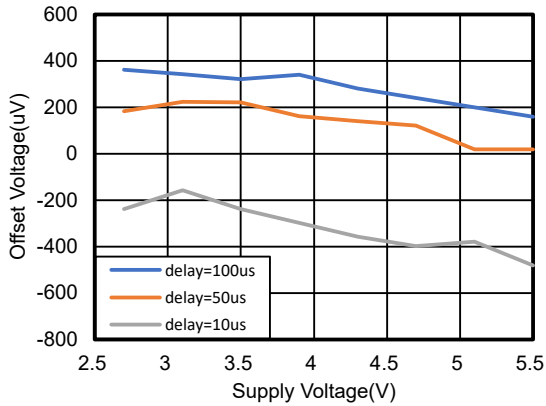

Figure 1. Input Offset Voltage vs. Supply Voltage

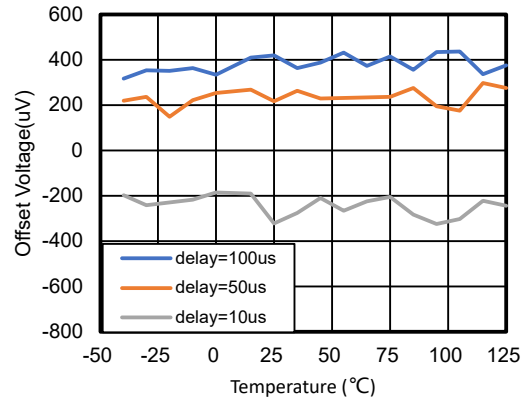

Figure 2. Input Offset Voltage vs. Temperature

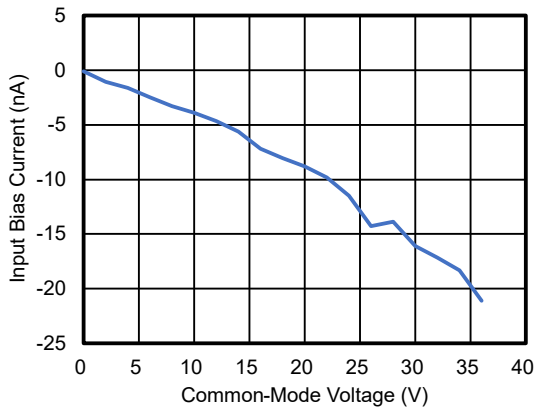

Figure 3. Input Bias Current vs. Common-Mode Voltage (Enabled)

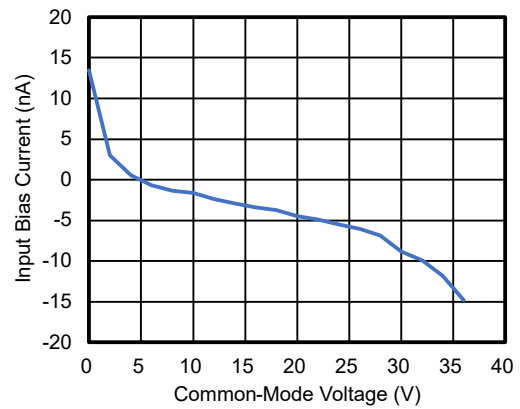

Figure 4. Input Bias Current vs. Common-Mode Voltage (Disabled)

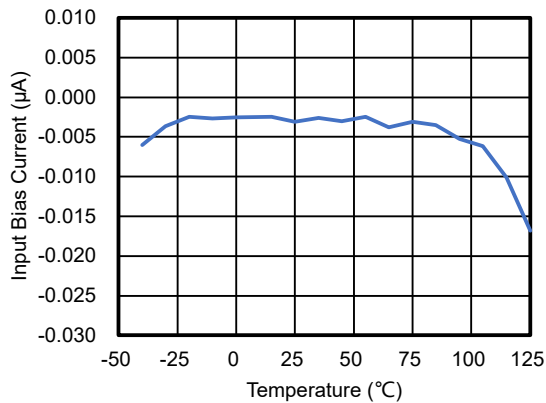

Figure 5. Input Bias Current vs. Temperature (Enabled)

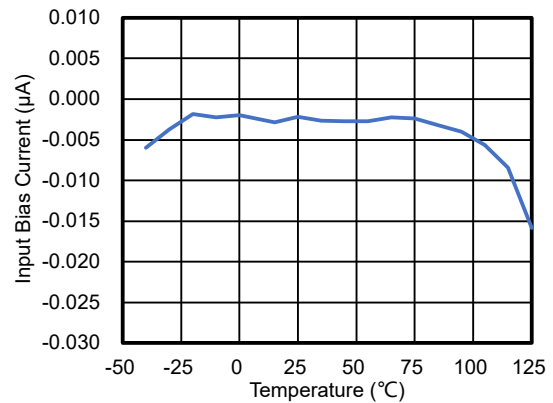

Figure 6. Input Bias Current vs. Temperature (Disabled)

36-V, Overcurrent-Protection, Current Sense Comparator

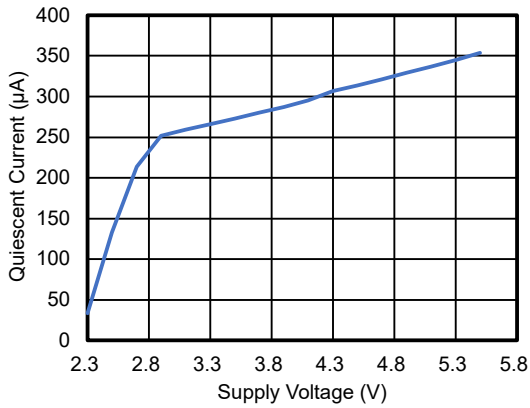

Figure 7. Quiescent Current vs. Supply Voltage (Enabled)

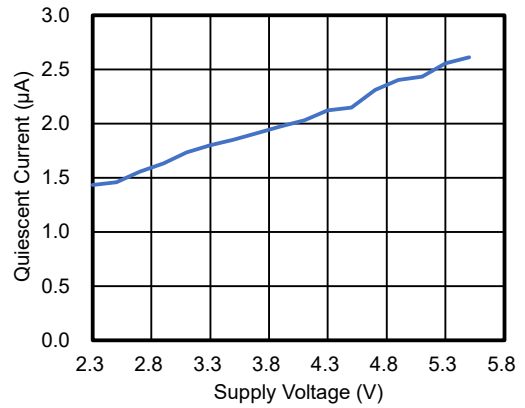

Figure 8. Quiescent Current vs. Supply Voltage (Disabled)

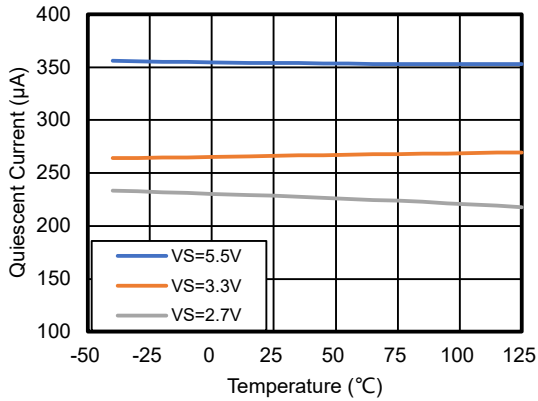

Figure 9. Quiescent Current vs. Temperature (Enabled)

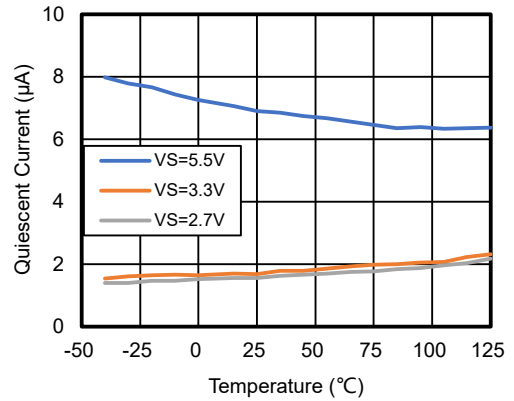
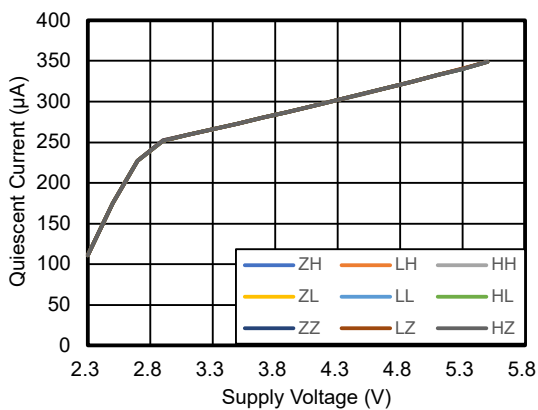

Figure 10. Quiescent Current vs. Temperature (Disabled)



Z = Floating, L = Low, H = High

HYS – Delay

Figure 11. Quiescent Current vs. HYS and Delay Settings (Enabled)

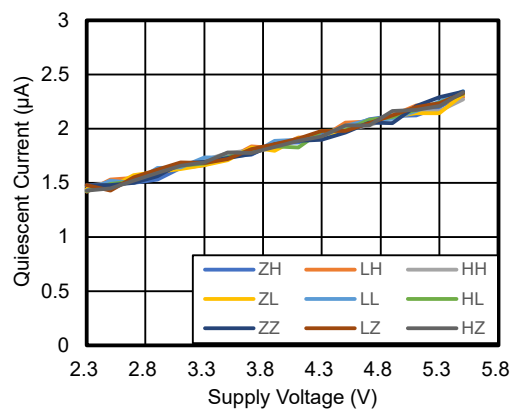

Z = Floating, L = Low, H = High

HYS – Delay

Figure 12. Quiescent Current vs. HYS and Delay Settings (Disabled)

36-V, Overcurrent-Protection, Current Sense Comparator

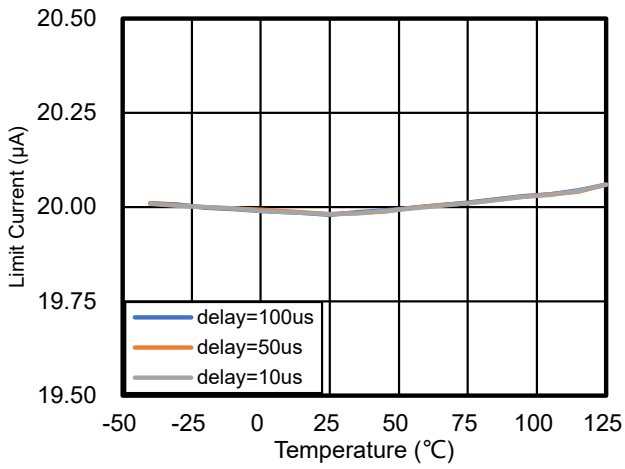

Figure 13. Limit Current Source vs. Temperature

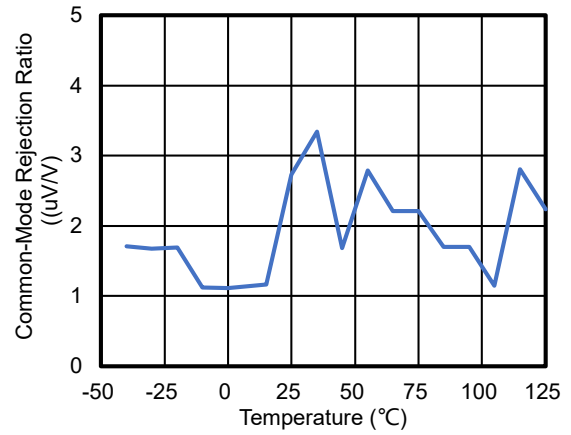

Figure 14. Common-Mode Rejection Ratio vs. Temperature

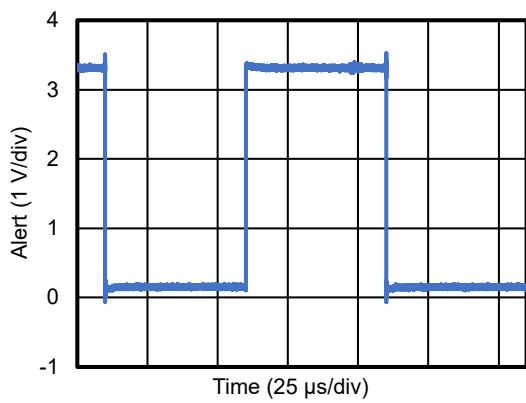

Figure 15. Alert Step Response

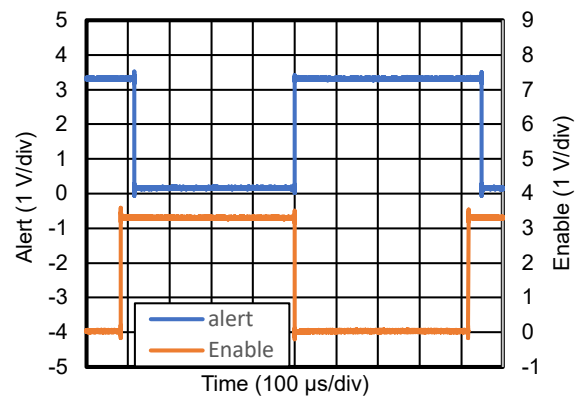

Figure 16. Alert Response (Disable to Enable)

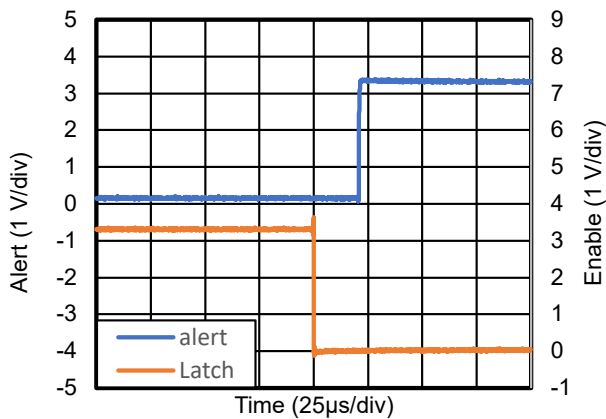

Figure 17. Alert Response (Latch Mode to Transparent Mode)

36-V, Overcurrent-Protection, Current Sense Comparator

Detailed Description

Overview

The TPA170C is a comparator for current sensing applications. The device can operate on a supply voltage from 2.7 V to 5.5 V and offer a 36-V common-mode voltage range. The output function is present at the alert terminal. The alert terminal is an open-drain output. This terminal needs to be pulled up to the supply voltage by a resistor. A 10-k Ω resistor is recommended.

The TPA170C compares the differential mode input voltage with the threshold voltage. The alert terminal is pulled low when the differential mode input voltage exceeds the threshold. The threshold voltage can be configured by adding a resistor between the limit terminal and GND. The alert terminal keeps a high level with the input voltage below the threshold. Such alert terminal output behaviors make the device especially suitable for overcurrent detection. The 250-mV differential mode input range offers a wide range of detection.

Feature Description

Current Limit Threshold Setting

The comparison threshold voltage is set by the voltage at the limit terminal. There are two ways to set the threshold (V_{LIMIT}). One is to apply a certain voltage by connecting an external voltage source at the limit terminal, and the other is to add a resistor R_{LIMIT} between the limit terminal and GND. An internal 20- μ A current source flows out from the limit terminal, which creates a voltage dropout ($20 \mu\text{A} \times R_{LIMIT}$) as the comparison threshold on R_{LIMIT} .

Delay Setting

The delay terminal determines the delay time when the input voltage exceeds the threshold before the alert terminal turns low. There are three selections for delay time configurations, including 10 μ s, 50 μ s, and 100 μ s, giving users a more flexible response time during the overcurrent detection for system designs.

The device has a comparison window in which it continuously detects the input voltage. The comparison window maintains the delay time setting by the delay terminal. For example, when the delay time is 10 μ s, the input voltage needs to exceed the threshold for 10 μ s to make the alert terminal turn to a low level. If there is a voltage below the threshold in the comparison window, the output alert can not be triggered, and the alert terminal keeps high. The 50- μ s and 100- μ s delay time effects are similar to those in the 10- μ s delay time settings. The comparison window maintains for 50 μ s or 100 μ s depending on the 50- μ s or 100- μ s delay settings.

The comparison window not only exists in alert-triggered events but also functions in alert recovery. The input voltage needs to be lower than the threshold successively during the delay time to make the alert terminal return to a high level. Such recovery behavior is the characteristic in the transparent mode. The transparent mode is introduced in [Alert Mode](#).

The delay time is set by connecting the delay terminal to the supply voltage or GND, or is left floating. The relationship between the delay terminal connection and delay time is shown in [Table 2](#). When the delay time is 100 μ s or 50 μ s, it is not recommended to add a resistor between the delay terminal and the supply voltage or GND.

Table 2. Delay Setting

Delay Terminal Connection	Delay Time (μ s)
Supply Voltage	100
GND	50
Floating	10

36-V, Overcurrent-Protection, Current Sense Comparator

Hysteresis Setting

The hysteresis voltage (V_{HYS}) is set by the HYS terminal. V_{HYS} influences the recovery threshold. When the input voltage is lower than the recovery threshold ($V_{LIMIT} - V_{HYS}$), the alert event is removed, and the alert terminal returns to a high level. The combination of V_{LIMIT} and V_{HYS} contributes to the alert terminal behavior as the input voltage changes. This feature is represented in [Figure 18](#).

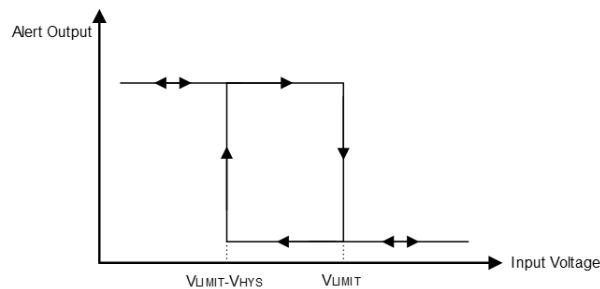

Figure 18. Hysteresis Feature

There are three V_{HYS} voltages including 8 mV, 4 mV, and 2 mV by connecting the HYS terminal to the supply voltage, or GND, or left floating. Three V_{HYS} voltage selections help users recognize overcurrent events disappeared in different applications. When the hysteresis voltage is 8 mV or 4 mV, it is not recommended to add a resistor between the HYS terminal and the supply voltage or GND. The relationship between the HYS terminal and V_{HYS} is shown in [Table 3](#).

Table 3. Hysteresis Settings

HYS Terminal Connection	Hysteresis Voltage (mV)
Supply Voltage	8
GND	4
Floating	2

Disable Mode

The enable terminal determines whether the device is enabled or not. The device is disabled when the enable terminal keeps low. The power consumption is about 2 μ A in the disable mode, offering benefits for battery-powered scenarios. The time is in microseconds when the state of the device changes between the enable mode and disabled mode, giving a short time to function normally. The relationship between the enable mode and the enable terminal is shown in [Table 4](#).

Table 4. Enable and Disable Mode Settings

Enable Mode	Enable Terminal State
Enable Mode	High
Disable Mode	Low

Alert Mode

The alert mode consists of the transparent mode and the latch mode. The alert mode is determined by the latch terminal. The selection of the alert mode influences the alert terminal behaviors when the input voltage changes.

The device is configured in the transparent mode when the latch terminal is kept low. In the transparent mode, the alert terminal is pulled low when the input voltage exceeds V_{LIMIT} , and returns to a high level with the input voltage below $V_{LIMIT} - V_{HYS}$. Both of the two input voltage behaviors that cause changes in the alert terminal state must meet the delay time requirement in comparison window settings. Otherwise, the alert terminal keeps its state unchanged.

36-V, Overcurrent-Protection, Current Sense Comparator

The device is configured to latch mode when the latch terminal is kept high. The difference between the transparent mode and latch mode is the alert terminal behavior when the input voltage is below the threshold. In the latch mode, the alert terminal is pulled low when the input voltage exceeds V_{LIMIT} , but it does not return to a high level with the input voltage below $V_{LIMIT} - V_{HYS}$. This feature in the latch mode helps users capture any overcurrent events in the system, while such events vanish in the transparent mode. To make the alert terminal return to a high level, the device must be in the transparent mode and the input voltage is below the $V_{LIMIT} - V_{HYS}$. Keep the latch terminal low for at least 2 μ s to exit the latch mode.

Power Supply Recommendations

To realize better noise decouple performance on the power supply, place the power supply bypass capacitor as close as possible to the supply and the ground terminal. A 0.1- μ F capacitor is recommended. Additional bypass capacitors get better noise suppression on the power supply.

Tape and Reel Information

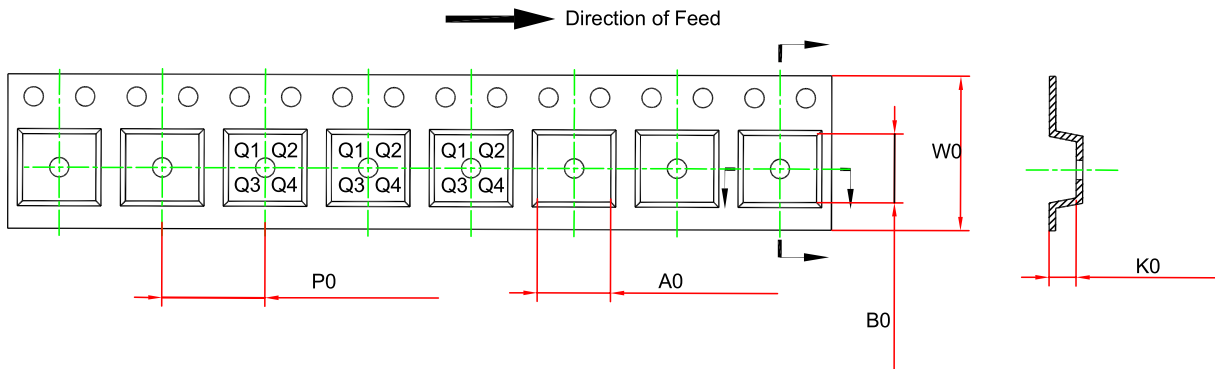
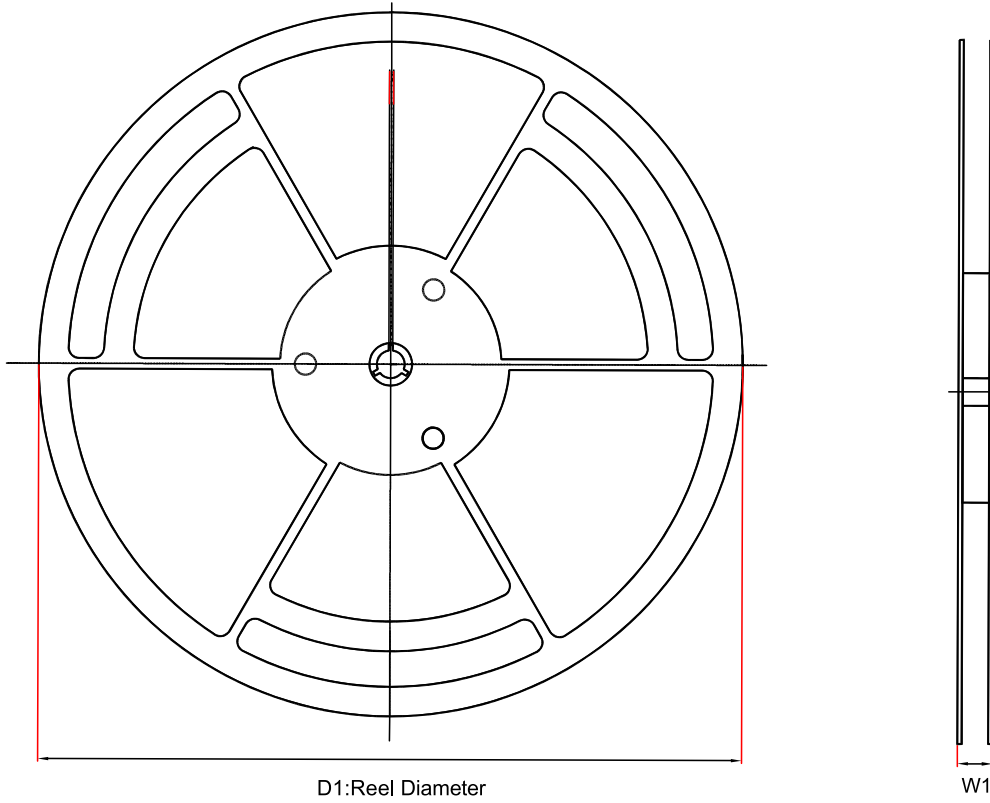

Order Number	Package	D1 (mm)	W1 (mm)	A0 (mm) (1)	B0 (mm) (1)	K0 (mm) (1)	P0 (mm)	W0 (mm)	Pin1 Quadrant
TPA170C- DFFR-S	DFN2x2-10	180	12.5	2.3	2.3	1.1	4	8	Q2
TPA170C- VS2R-S	MSOP10	330	17.6	5.3	3.4	1.4	8	12	Q1

(1) The value is for reference only. Contact the 3PEAK factory for more information.

Package Outline Dimensions

DFN2×2-10

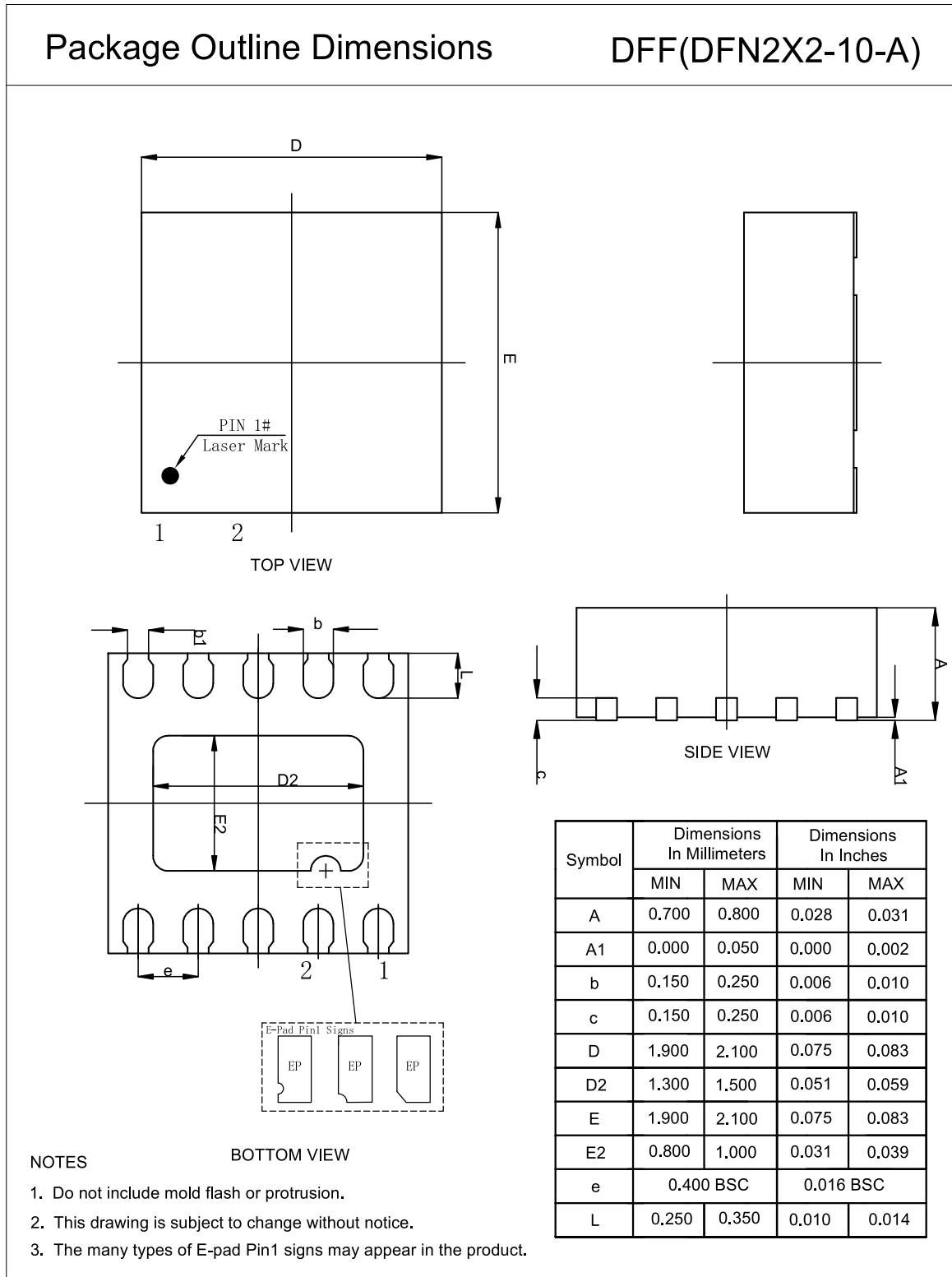

MSOP10

Package Outline Dimensions

VS2(MSOP-10-A)

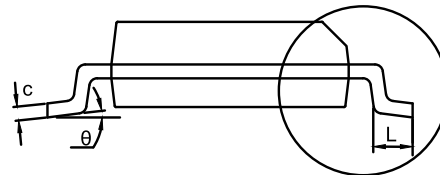
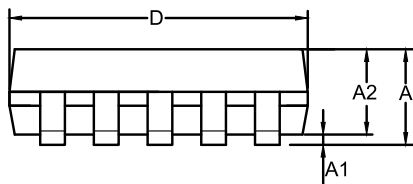
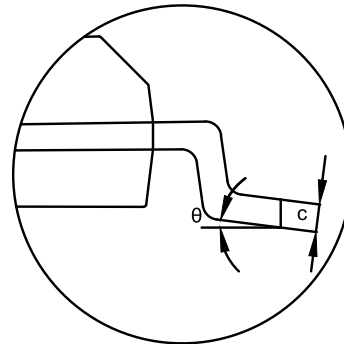
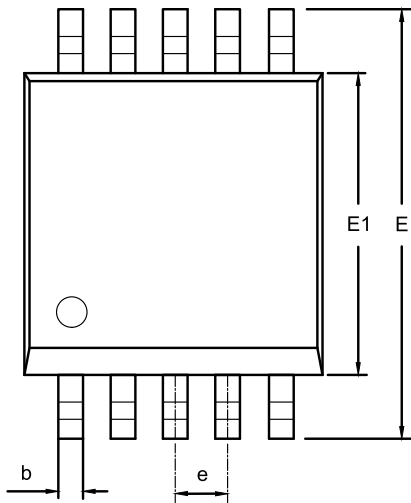

Symbol	Dimensions In Millimeters		Dimensions In Inches	
	MIN	MAX	MIN	MAX
A	0.800	1.100	0.031	0.043
A1	0.050	0.150	0.002	0.006
A2	0.750	0.950	0.030	0.037
b	0.180	0.280	0.007	0.011
c	0.090	0.230	0.004	0.009
D	2.900	3.100	0.114	0.122
E	4.700	5.100	0.185	0.201
E1	2.900	3.100	0.114	0.122
e	0.500 BSC		0.020 BSC	
L	0.400	0.800	0.016	0.031
θ	0	8°	0	8°

NOTES

1. Do not include mold flash or protrusion.
2. This drawing is subject to change without notice.

Order Information

Order Number	Package	Marking Information	MSL	Transport Media, Quantity	Eco Plan
TPA170C-DFFR-S	DFN2×2-10	70C	MSL1	Tape and Reel, 3,000	Green
TPA170C-VS2R-S ⁽¹⁾	MSOP10	A170C	MSL1	Tape and Reel, 3,000	Green

(1) Future Product.

Green: 3PEAK defines "Green" to mean RoHS compatible and free of halogen substances.

IMPORTANT NOTICE AND DISCLAIMER

Copyright© 3PEAK 2012-2025. All rights reserved.

Trademarks. Any of the 思瑞浦 or 3PEAK trade names, trademarks, graphic marks, and domain names contained in this document /material are the property of 3PEAK. You may NOT reproduce, modify, publish, transmit or distribute any Trademark without the prior written consent of 3PEAK.

Performance Information. Performance tests or performance range contained in this document/material are either results of design simulation or actual tests conducted under designated testing environment. Any variation in testing environment or simulation environment, including but not limited to testing method, testing process or testing temperature, may affect actual performance of the product.

Disclaimer. 3PEAK provides technical and reliability data (including data sheets), design resources (including reference designs), application or other design recommendations, networking tools, security information and other resources "As Is". 3PEAK makes no warranty as to the absence of defects, and makes no warranties of any kind, express or implied, including without limitation, implied warranties as to merchantability, fitness for a particular purpose or non-infringement of any third-party's intellectual property rights. Unless otherwise specified in writing, products supplied by 3PEAK are not designed to be used in any life-threatening scenarios, including critical medical applications, automotive safety-critical systems, aviation, aerospace, or any situations where failure could result in bodily harm, loss of life, or significant property damage. 3PEAK disclaims all liability for any such unauthorized use.